

RB4000 Series Regulator

Commercial & Industrial Regulator

Applications

The RB4000 regulator is designed for gas supply networks, district station regulation, industrial service regulation, and all applications where accurate pressure control, ease of adjustment, and fast response are required such as for burners, industrial ovens, boilers, etc.

Description

The RB4000 employs a direct-acting, spring-loaded regulator. The balanced valve design ensures a constant outlet pressure when the upstream pressure varies. A built-in pulsation damper allows stable pressure control even at very low flow rates. An optional built-in shut-off valve offers protection against over-pressure or under-pressure.

Benefits

- > Accurate regulation
- > High flow accuracy
- > Fast response for sharp on-off loads
- > Easy maintenance
- > Compact size
- > Rugged construction for durability
- > Balanced valve design eliminates inlet pressure effect
- > Wide range of outlet pressures
- > Horizontal or Vertical mounting

Features

- > Interchangeable adjustment spring
- > Balanced valve design
- > Downstream control
- > Direct acting spring loaded design
- > Over pressure shut-off (OPCO) available
- > Under pressure shut-off (UPCO) available
- > Built-in silencer available
- > Monitor version available



Shipping weight:

1 regulator per box Box weight: 121 lbs.

RB4000 Dimensions (inches)

Valve Body Size	Dimensions (inches)	Without Built-in Shut-off Valve			With Built-in Shut-off Valve		
		RB4010	RB4020	RB4030-40	RB4011-12	RB4021-22	RB4031-32
2"	A	10	10	10	10	10	10
	B	22.2	21.3	21.3	22.2	21.3	21.3
	C	3.9	3.9	3.9	3.9	3.9	3.9
	D	18.9	14.2	14.2	18.9	14.2	14.2
	E	-	-	-	12.0	12.0	10.9
	F	-	-	-	5.9/3.5	5.9/3.5	5.9/3.5
	G	-	-	-	5.7	5.7	5.7
	Weight (lbs.)	90.4	63.9	72.8	105.8	77.2	86.0
3"	A	11.7	11.7	11.7	11.7	11.7	11.7
	B	28.0	25.8	24.6	28.0	25.8	24.6
	C	5.1	5.1	5.1	5.1	5.1	5.1
	D	23.6	18.9	14.2	23.6	18.9	14.2
	E	-	-	-	14.3	14.3	13.1
	F	-	-	-	5.9/3.5	5.9/3.5	5.9/3.5
	G	-	-	-	7.3	7.3	7.3
	Weight (lbs.)	154.3	123.5	108.0	178.6	147.7	132.3

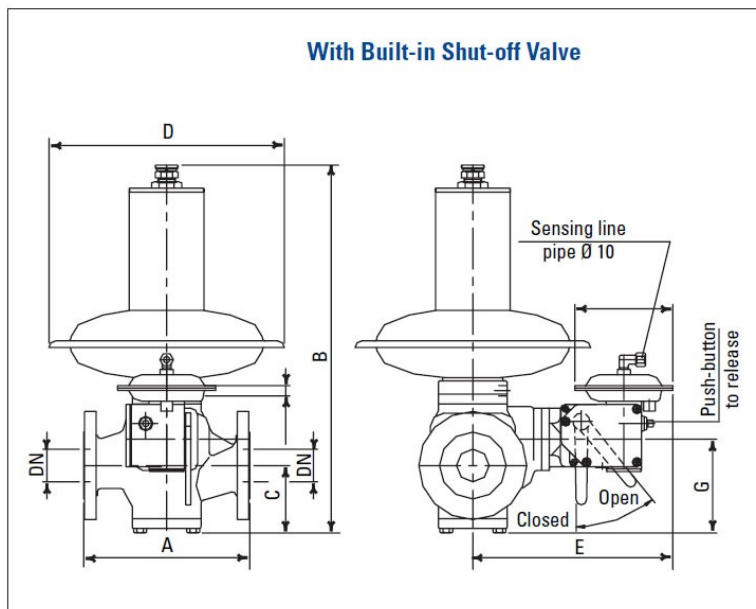
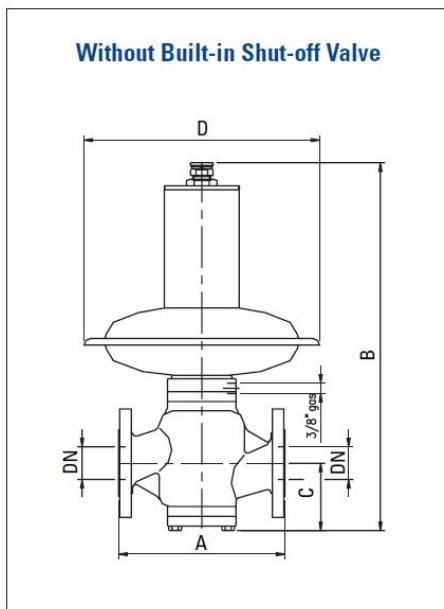

Operational Schematic

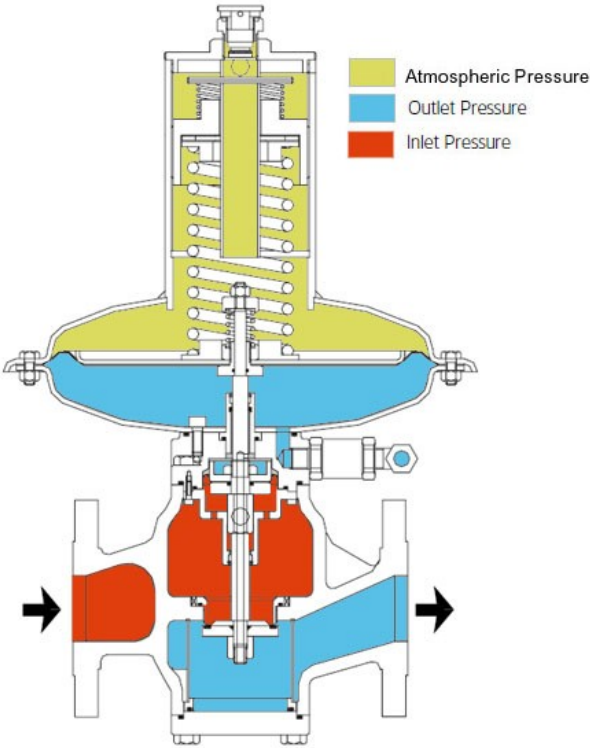

Spring Color Outlet Pressure Ranges: 2" Valve Body

Spring Color	RB4010			RB4020			RB4030		
	Spring Range ("w.c./PSIG)		4010 Basic Set Point	Spring Range ("w.c./PSIG)		4020 Basic Set Point	Spring Range ("w.c./PSIG)		4030 Basic Set Point
Orange/silver	4.0	5.6	5" w.c.	-	-	-	-	-	-
Brown/silver	5.6	7.6	7" w.c.	-	-	-	-	-	-
Dark green/silver	7.6	10.7	9" w.c.	-	-	-	-	-	-
Light green/silver	10.0	14.5	14" w.c.	-	-	-	-	-	-
Light blue/silver	14.1	19.3	-	1.0	1.5	1 PSIG	-	-	-
Purple/silver	0.8	1.2	1 PSIG	1.6	2.6	2 PSIG	-	-	-
Yellow	1.2	1.9	---	2.6	4.1	3 PSIG	-	-	-
Blue/silver	1.6	2.1	2 PSIG	4.1	5.4	5 PSIG	-	-	-
Blue	-	-	-	3.9	6.5	-	-	-	-
Silver	-	-	-	6.9	9.5	-	10.0	14.6	10 PSIG
Purple	-	-	-	9.3	11.8	10 PSIG	14.2	17.2	-
Yellow/silver	-	-	-	11.5	14.3	-	16.9	22.2	15 PSIG
Red/silver	-	-	-	14.2	18.6	15 PSIG	21.5	28.7	20 PSIG

Spring Color Outlet Pressure Ranges: 3" Valve Body

Spring Color	RB4020			RB4030			RB4040		
	Spring Range ("w.c./PSIG)		4020 Basic Set Point	Spring Range ("w.c./PSIG)		4030 Basic Set Point	Spring Range ("w.c./PSIG)		4040 Basic Set Point
Orange/silver	-	-	-	-	-	-	-	-	-
Brown/silver	-	-	-	-	-	-	-	-	-
Dark green/silver	-	-	-	-	-	-	-	-	-
Light green/silver	-	-	-	-	-	-	-	-	-
Light blue/silver	-	-	-	-	-	-	-	-	-
Black/silver	-	-	-	-	-	-	-	-	-
Purple/silver	-	-	-	-	-	-	-	-	-
Yellow	1.2	1.9	-	2.6	-	-	-	-	-
Blue/silver	1.6	2.0	2 PSIG	-	-	-	-	-	-
Blue	1.7	3.4	3 PSIG	4.3	7.2	-	-	-	-
Silver	2.6	5.3	-	6.9	9.5	-	10.0	14.6	10 PSIG
Purple	3.4	5.3	5 PSIG	9.4	11.8	-	14.2	17.2	15 PSIG
Yellow/silver	4.3	6.7	-	11.5	14.3	10 PSIG	16.9	22.2	20 PSIG
Red/silver	5.4	7.2	-	14.2	18.6	15 PSIG	21.5	28.7	25 PSIG
White/silver	-	-	-	-	-	-	21.5	28.7	-

Overpressure Shut-off Valve Spring Ranges

Spring Color	Shut-off Models 8611 and 8612		Shut-off Models 8621 and 8622		Shut-off Models 8631 and 8632		Shut-off Models 8641 and 8642	
	6" Diaphragm (in. w.c.)		6" Diaphragm (PSIG)		3.5" Diaphragm (PSIG)		3.5" Diaphragm (PSIG)	
Yellow	11	26	1.74	3.19	2.90	5.51	4.64	8.41
Red	18	40	2.32	5.08	4.06	8.70	7.25	13.05
White	32	64	3.19	7.40	5.80	11.60	10.15	17.40
Blue	40	100	5.08	10.88	8.70	16.68	14.50	26.83
Orange	76	181	7.98	18.13	13.78	29.73	21.75	45.68
Brown	141	281	14.50	29.73	21.75	45.68	33.35	73.95
Green	181	350	21.75	36.25	29.00	55.10	44.95	84.10
Black	241	422	24.65	40.60	36.25	69.60	55.10	98.60
Gray	382	563	38.43	62.35	56.55	91.35	82.65	134.85
Yellow	---	---	---	---	72.50	116.00	130.50	188.50
Red	---	---	---	---	111.65	156.60	184.15	217.50

Under Pressure Shut-off Valve Spring Ranges

Spring Color	Shut-off Model 8612		Shut-off Model 8622		Shut-off Model 8632		Shut-off Model 8642	
	6" Diaphragm (in. w.c.)	6" Diaphragm (PSIG)	6" Diaphragm (PSIG)	3.5" Diaphragm (PSIG)	3.5" Diaphragm (PSIG)	3.5" Diaphragm (PSIG)	3.5" Diaphragm (PSIG)	
White	2	7	---	---	---	---	---	---
Blue	4	22	---	---	---	---	---	---
Orange	12	30	1.60	4.21	3.34	7.11	4.64	9.14
Brown	24	60	2.32	7.11	3.77	10.59	6.09	15.95
Green	84	297	4.64	14.50	7.54	14.50	7.54	22.48

Operating Temperature Range

- 4°F to 140°F

Additional Specifications

Vent Connection:

Other Available Options: Seal wire to indicate unapproved tampering

Model Designations

4	0	X	X	Valve Body	Options
		1			Low pressure
		2			Medium pressure
		3			High pressure
		4			High pressure (only for 3")
			0		Without shutoff valve
			1		With over pressure shutoff valve**
			2		With over and under pressure shutoff valve**
				2" Flange*	
				3" Flange*	

*Please specify valve body material on your order (Ductile Iron or Steel).

**Multiply capacity data by 0.7 when using shutoff valve versions.

Iron takes pride in delivering American made products with the utmost concern for safety, quality, and customer satisfaction.

Construction materials:

Body	Ductile Iron quality 500-7 UNI-ISO 1083, Steel quality ASTM A 216 WCB
Internal parts	Brass and Stainless Steel
Diaphragm	Synthetic rubber with fabric reinforcement
Seals	Nitrile rubber or Viton (on request)
Diaphragm casing & cover	UNI/EN 10025 pressed steel

Valve Body Size (inches)

Inlet	Outlet	Flanged	Orifice Diameter	Wide Open Flow Coefficient (K-Factor)
2"	2"	X	2"	4430
3"	3"	X	3"	8540

Correction factors for non-natural gas applications

The RB4000 may be used to control gases other than natural gas. To determine the capacity for gases other than natural gas, multiply the values within the capacity tables by a correction factor. The table below lists the correction factors for some of the more common gases:

Gas Type	Specific Gravity	Correction Factor (CF)
Air	1.00	0.77
Butane	2.01	0.55
Carbon Dioxide (Dry)	1.52	0.63
Carbon Monoxide (Dry)	0.97	0.79
Natural Gas	0.60	1.00
Nitrogen	0.97	0.79
Propane	1.53	0.63
Propane-Air-Mix	1.20	0.71

To calculate the correction factor for gases not listed in the table above, use the gases' specific gravity and insert it in the formula listed below:

$$\text{Correction Factor (CF)} = \sqrt{\frac{SG_1}{SG_2}}$$

Where:

SG₁ = Specific gravity of the gas in which the capacity is published.

SG₂ = Specific gravity of the gas to be controlled.

Wide Open Flow Calculations

For wide-open orifice flow calculations use the following equations:

$$\text{For } P_1/P_2 < 1.89 \text{ use: } Q = K \sqrt{P_2(P_1 - P_2)} \quad \text{For } P_1/P_2 > 1.89 \text{ use: } Q = \frac{KP_1}{2}$$

Where:

P₁ = Absolute Inlet Pressure (PSIA)

P₂ = Absolute Outlet Pressure (PSIA)

Q = Flow Rate (SCFH)

K = Orifice Coefficient (SCFH/PSI)

Operational Schematic

Key

No.	Description
1	Spring chamber cover
2	Calibration spring
3	Diaphragm nut
4	Diaphragm chamber bottom case
5	Balancing diaphragm
6	Stem
7	Valve orifice
8	Inlet chamber
9	Valve seat
10	Valve plug
11	Outlet chamber
12	Balancing tube
13	Control line intake
14	Regulation control chamber
15	Diaphragm
16	Spring housing cover
17	Spring adjustment lock nut
18	Vent plug
19	Shutoff valve diaphragm chamber
20	Diaphragm assembly
21	Over pressure adjustment spring
22	Under pressure adjustment spring
23	Shutoff valve outlet chamber
24	Control levers
25	Shutoff valve plug
26	By-pass
27	Reset lever
28	Shutoff valve spring
29	Shutoff valve seat

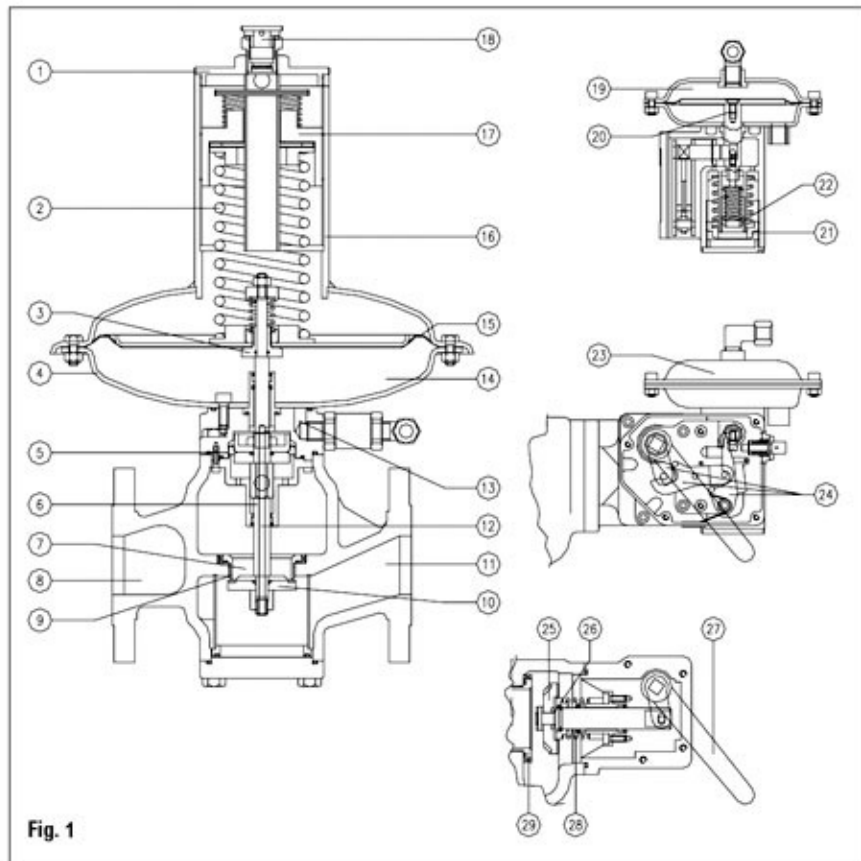

Fig. 1

Principle of Operation

A. Normal operation. The internal monitor IM orifice performs like a standard regulator and monitor regulator in that main orifice and valve seat actuate to control outlet flow and pressure under normal flow conditions. If there is no demand, the main seat and internal monitor orifice will close.

B. Monitor operation. If the main valve seat fails to control the gas flow and pressure due to foreign matter between the seat and orifice face, or if the seat is eroded, the internal monitor orifice automatically goes into operating position at a slightly higher outlet pressure (see Internal Monitor Lock-up Pressure table). Any time the pressure on the main diaphragm exceeds the force of the fixed monitor spring, the increased outlet pressure causes the main valve seat to push against the sliding orifice. The sliding orifice compresses the monitor spring and positions the monitor orifice to control the gas flow. The IM orifice now functions as a monitor regulator and continues to monitor as long as the main seat fails to control at the normal adjusted outlet pressure. If the gas load demand is increased beyond the internal monitor's capacity, the outlet pressure is reduced to normal adjusted pressure and the regulator resumes normal regulation.

C. Monitor lock-up. If the demand for gas is decreased to zero flow during monitor operation, the sliding orifice continues to close until its orifice is in the gas tight position (monitor lock-up) against the BUNA-N monitor valve seat. (See the Internal Monitor Lock-up Pressure table for the outlet pressure required for internal monitor lock-up.)

D. Vent hole V option. On installations where a small volume of over-pressure gas can be safely vented to the atmosphere, the advantages of both the pilot relief valve and monitor safety can be combined. If the flow is decreased to zero or just greater than zero, the vent hole in the internal monitor orifice allows gas to slowly bleed downstream and cause the pressure to rise to the relief point of the pilot's internal relief valve. The gas then bleeds to the atmosphere indicating a problem with the regulator.

RB4000 Series Commercial Regulator

RB4010 Capacity Table 2" Valve Body

Capacities in MCFH of 0.6 S.G. gas; base conditions of 14.7 PSIA and 60° F.

Typical Capacity Info.

Manufacturer	Itron
Type and model	RB4010

Inlet Pressure (PSIG)	Outlet Pressure Setting					
	7" w.c	14" w.c	1 PSIG		2 PSIG	
	1" w.c. droop	2" w.c. droop	1% absolute droop	2% absolute droop	1% absolute droop	2% absolute droop
1	14.2					
2	18.0	17.5	16.0	17.0		
3	23.5	25.0	22.5	25.7	10.3	17.8
5	38.0	34.3	32.5	38.3	16.3	28.6
8	43.9	38.9	33.5	43.9	22.7	39.9
10	47.9	55.8	56.3	64.3	26.2	47.5
15	57.4	75.6	56.1	64.1	32.6	57.5
20	67.0	94.8	65.5	74.8	40.7	67.0
30	86.2	96.2	84.4	96.4	45.5	79.0
40	105.4	99.6	103.3	118.0	52.8	98.2
50	124.6	117.9	122.2	139.6	58.5	120.6
60	143.8	136.1	141.0	161.1	77.3	139.3
70	162.9	154.3	159.9	182.7	87.7	158.0
80	182.1	172.5	178.8	204.2	98.1	176.7
90	201.3	190.7	197.7	225.8	108.5	195.4
100	220.5	208.9	216.6	247.4	118.9	214.2
120	261.2	245.4	254.3	290.5	139.7	251.6
150	316.4	566.4	311.0	355.2	170.8	307.8
175	364.3	652.4	358.2	409.2	196.8	354.6
200	412.3	738.4	405.4	463.1	222.8	401.4
225	460.2	824.4	452.6	517.0	248.8	448.1
Lock up (PSIG)	1" w.c.	1.5" w.c.	0.1		0.2	

Notes:

*Individual regulator performance may vary from data shown.



Inlet pressure is too low to deliver set point.

RB4000 Series Commercial Regulator

RB4020 Capacity Table 2" Valve Body

Capacities in MCFH of 0.6 S.G. gas; base conditions of 14.7 PSIA and 60° F.

Typical Capacity Info.

Manufacturer	Itron
Type and model	RB4020

Inlet Pressure (PSIG)	Outlet Pressure Setting							
	1 PSIG	2 PSIG		5 PSIG		10 PSIG		
	1% absolute droop	1% absolute droop	2% absolute droop	1% absolute droop	2% absolute droop	1% absolute droop	10% gauge droop	2% gauge droop
1								
2	15.2							
3	19.7	10.3	17.8					
5	27.2	16.3	28.6					
8	34.8	22.7	39.9	16.0	23.6			
10	38.2	26.2	47.5	20.8	28.9			
15	46.2	32.6	57.5	30.8	46.4	17.8	34.8	50.8
20	52.4	40.7	67.0	36.6	49.4	24.9	47.6	69.1
30	68.1	45.5	79.0	43.5	62.8	35.9	68.0	98.2
40	87.2	52.8	98.2	53.8	76.4	44.4	85.2	121.0
50	100.3	58.5	120.6	63.6	90.4	50.0	92.6	133.3
60	115.9	77.3	139.3	70.5	97.4	65.4	117.3	166.6
70	131.5	87.7	158.0	83.4	118.5	65.5	121.3	174.6
80	147.1	98.1	176.7	93.3	132.5	73.2	135.7	195.3
90	162.6	108.5	195.4	94.4	134.0	89.9	157.6	225.3
100	178.2	118.9	214.2	113.0	160.6	88.8	164.4	236.7
120	211.4	141.0	251.6	121.0	188.7	105.4	193.2	278.1
150	256.1	170.8	307.8	126.8	191.0	131.4	213.0	315.3
175	295.1	196.8	354.6	139.6	203.0	146.9	232.3	349.9
200	334.0	222.8	401.4	211.9	301.0	166.3	308.2	443.6
225	372.9	248.8	448.1	236.6	336.1	185.7	344.1	495.3
Lock up (PSIG)	0.2	0.3		0.3		0.5		

Notes:

*Individual regulator performance may vary from data shown.

 Inlet pressure is too low to deliver set point.

RB4000 Series Commercial Regulator

RB4030 Capacity Table 2" Valve Body

Capacities in MCFH of 0.6 S.G. gas; base conditions of 14.7 PSIA and 60° F.

Typical Capacity Info.

Manufacturer	Itron
Type and model	RB4030

Inlet Pressure (PSIG)	Outlet Pressure Setting							
	10 PSIG		15 PSIG		20 PSIG		30 PSIG	
	10% gauge droop	20% gauge droop	10% gauge droop	20% gauge droop	10% gauge droop	20% gauge droop	10% gauge droop	20% gauge droop
15	29.0	49.5						
20	36.0	70.0	34.9	57.8				
30	59.2	89.0	58.9	88.2	49.8	87.5		
40	70.6	115.5	73.0	114.0	69.6	120.0	49.3	85.5
50	78.0	123.3	77.0	121.6	84.7	136.8	59.8	110.8
60	90.4	144.2	89.4	141.2	98.3	158.8	69.4	128.6
70	102.9	162.9	97.3	146.2	115.9	181.7	80.4	151.1
80	113.1	180.2	114.2	180.3	125.5	202.8	88.6	164.2
90	121.6	199.3	126.6	199.9	139.1	224.8	98.2	182.0
100	133.2	214.5	138.0	221.6	163.2	250.2	107.9	199.8
120	159.5	250.1	160.4	255.3	186.7	292.8	127.1	235.5
150	184.4	303.0	189.1	314.0	223.2	352.0	155.9	302.9
175	214.1	357.1	231.9	366.1	254.8	411.8	180.0	333.4
200	260.3	419.9	262.9	415.0	288.8	466.8	204.0	378.0
225	291.0	469.4	293.8	463.9	322.8	521.7	228.0	422.5
Lock up (PSIG)	0.5	0.8		0.9		1.3		

Notes:

*Individual regulator performance may vary from data shown.

 Inlet pressure is too low to deliver set point.

RB4000 Series Commercial Regulator

RB4020 Capacity Table 3" Valve Body

Capacities in MCFH of 0.6 S.G. gas; base conditions of 14.7 PSIA and 60° F.

Typical Capacity Info.

Manufacturer	Itron
Type and model	RB4020

Inlet Pressure (PSIG)	Outlet Pressure Setting					
	1 PSIG		3 PSIG		5 PSIG	
	1% absolute droop	2% absolute droop	1% absolute droop	2% absolute droop	1% absolute droop	2% absolute droop
3	44.3	50.6				
5	64.0	75.4	32.1	46.2		
8	66.0	86.5	44.7	64.4	31.5	46.5
10	110.9	126.7	51.6	74.3	41.0	56.9
15	110.5	126.2	64.2	92.5	60.6	91.3
20	129.1	147.4	80.2	115.5	72.1	97.3
30	166.3	189.9	89.6	129.1	85.7	123.7
40	203.4	232.4	104.0	149.8	105.9	150.5
50	240.6	274.9	115.2	166.0	125.4	178.1
60	277.8	317.4	152.3	219.3	138.9	191.9
70	315.0	359.9	172.8	248.8	164.3	233.5
80	352.2	402.4	193.2	278.3	183.8	261.1
90	389.4	444.9	213.7	307.8	186.0	264.0
100	426.6	487.4	234.2	337.2	222.7	316.4
120	501.0	572.4	275.1	396.2	238.4	371.8
150	612.6	699.8	336.5	484.6	249.8	376.3
175	705.6	806.1	387.7	558.3	275.0	399.9
200	798.5	912.3	438.9	632.0	417.4	539.0
225	891.5	1018.5	490.1	705.7	466.0	662.2
Lock up (PSIG)	0.1		0.2		0.35	

Notes:

*Individual regulator performance may vary from data shown.

 Inlet pressure is too low to deliver set point.

RB4000 Series Commercial Regulator

RB4030 Capacity Table 3" Valve Body

Capacities in MCFH of 0.6 S.G. gas; base conditions of 14.7 PSIA and 60° F.

Typical Capacity Info.

Manufacturer	Itron
Type and model	RB4030

Inlet Pressure (PSIG)	Outlet Pressure Setting			
	10 PSIG		15 PSIG	
	10% gauge droop	20% gauge droop	10% gauge droop	20% gauge droop
15	57.1	97.5		
20	70.9	137.9	68.8	113.9
30	116.6	175.3	116.0	173.8
40	139.1	227.5	143.8	224.6
50	153.7	242.9	151.8	239.6
60	178.1	284.1	176.2	278.2
70	202.7	320.9	191.7	288.0
80	222.8	355.0	225.0	355.2
90	239.6	392.6	249.4	393.7
100	262.4	422.6	271.9	436.6
120	314.2	492.7	316.0	502.9
150	363.3	596.9	372.5	618.6
175	421.8	703.5	456.8	721.2
200	512.8	827.2	517.8	817.5
225	573.3	924.7	578.8	913.9
Lock up (PSIG)	0.5		0.8	

Notes:

*Individual regulator performance may vary from data shown.

 Inlet pressure is too low to deliver set point.

RB4000 Series Commercial Regulator

RB4040 Capacity Table 3" Valve Body

Capacities in MCFH of 0.6 S.G. gas; base conditions of 14.7 PSIA and 60° F.

Typical Capacity Info.

Manufacturer	Itron
Type and model	RB4040

Inlet Pressure (PSIG)	Outlet Pressure Setting							
	10 PSIG		15 PSIG		20 PSIG		30 PSIG	
	10% gauge droop	20% gauge droop	10% gauge droop	20% gauge droop	10% gauge droop	20% gauge droop	10% gauge droop	20% gauge droop
15	52.0	88.7						
20	67.4	131.0	63.3	104.8				
30	106.1	159.6	109.1	163.3	98.1	172.4		
40	132.1	216.2	132.3	206.6	137.1	236.4	97.1	168.4
50	139.8	221.0	142.7	225.3	166.8	269.5	117.8	218.3
60	169.2	269.9	162.1	255.9	193.6	312.9	136.7	253.3
70	184.5	292.0	180.2	270.7	228.3	357.9	158.4	297.7
80	211.7	337.2	207.0	326.8	247.2	399.5	174.6	323.5
90	218.0	357.3	234.4	370.1	274.0	442.9	193.5	358.6
100	249.3	401.4	250.1	401.6	321.5	492.9	212.5	393.7
120	285.9	448.4	297.0	472.8	367.8	576.8	250.3	463.9
150	345.1	567.1	342.7	569.1	439.7	693.4	307.2	596.7
175	383.8	640.2	429.4	677.9	501.9	811.2	354.5	656.9
200	487.2	785.8	476.4	752.1	569.0	919.5	401.8	744.6
225	521.7	841.4	544.1	859.0	636.0	1027.8	449.2	832.3
Lock up (PSIG)	0.6		1.0		1.1		1.5	

Notes:

*Individual regulator performance may vary from data shown.

 Inlet pressure is too low to deliver set point.

Troubleshooting Guide

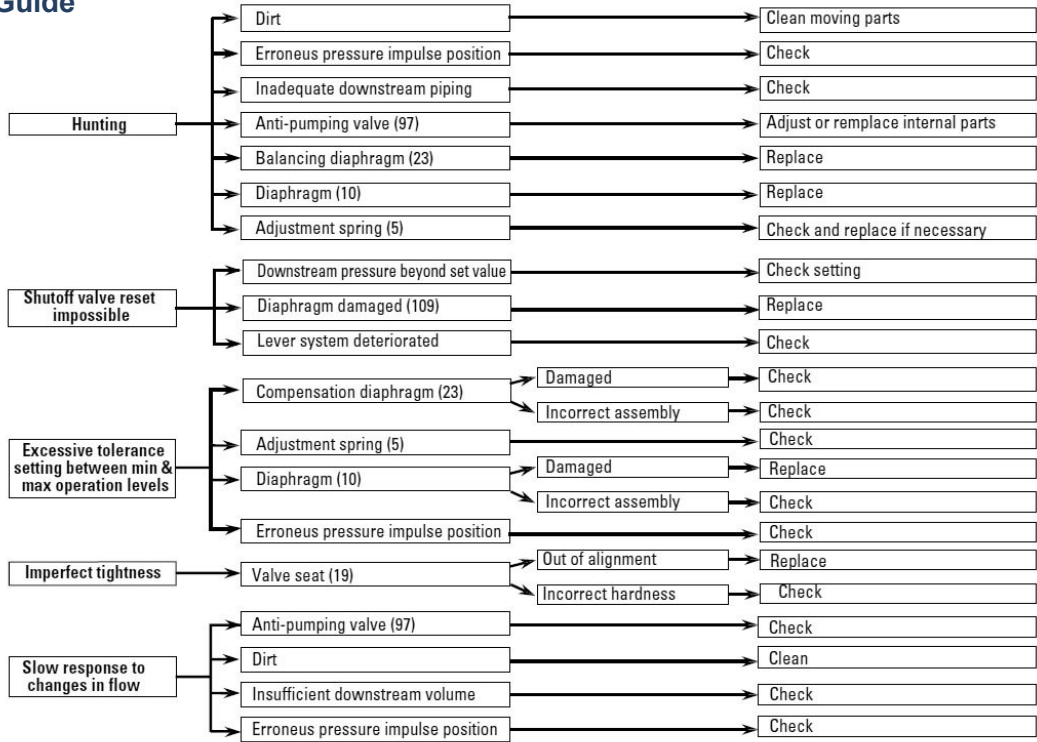

Pressure Beyond Regulator Setting

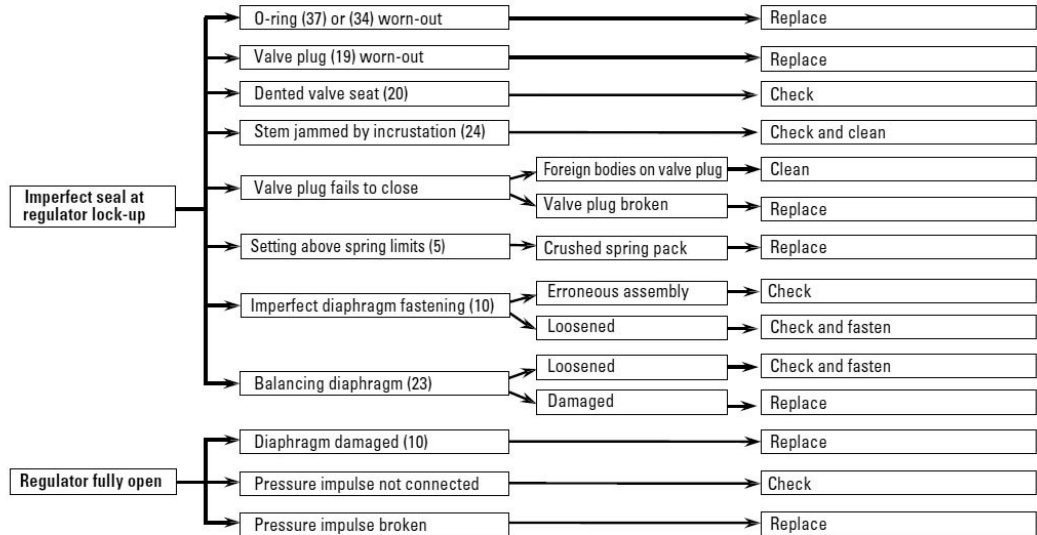

No Flow

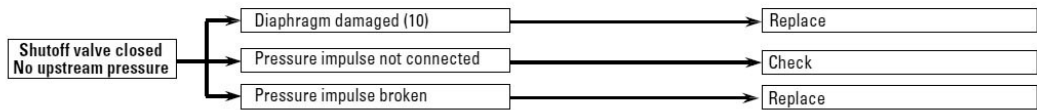

Low Downstream Pressure and Flow

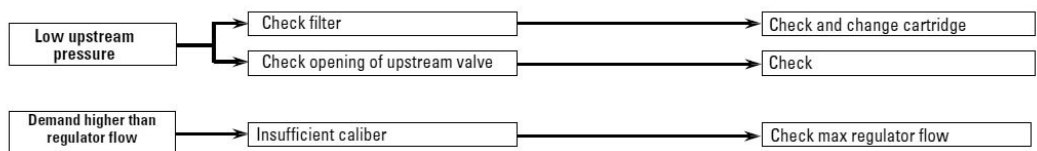

RB4000 Parts Diagram

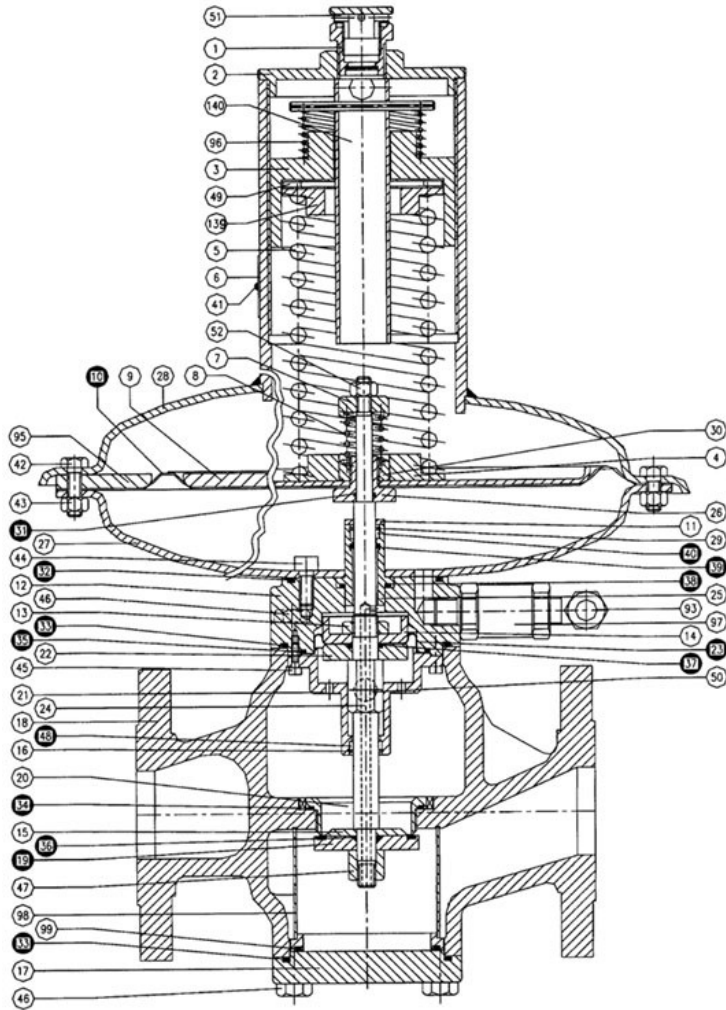

Parts List

Spare Parts Kit -RB4000	
Part Number	Description
39926101	Spare parts kit RB 4010 2" Body
39926201	Spare parts kit RB 4020 2" Body
39926301	Spare parts kit RB 4030 2" Body
39927200	Spare parts kit RB 4020 3" Body
39927300	Spare parts kit RB 4030 3" Body
39927400	Spare parts kit RB 4040 (3" Body)
39927120	Spare parts kit list RB 4011-4012 (3" Body)
39927310	Spare parts kit list for RB 4031-4032 (3" Body)
39927410	Spare parts kit list for RB 4041-4042 (3" Body)

Spare Parts Kit RB 4010 2" Body

Item Number	Part Number	Qty.	Description
10	20550290	1	Diaphragm RB 4010 (2" Body) (Rev.0)
19	20600260	1	Valve Plug SHA 55 RB 4010 (2" Body) (Rev.C)
23	20556290	1	Balancing Diaphragm RB 4000 (2" Body) (II Series) (Rev.0)
31	45000108	1	O-ring or 108
32	45004312	1	O-ring or 4312
33	45004325	2	O-ring or 4325
34	45003231	1	O-ring or 3231
35	45003262	1	O-ring or 3262
36	45000112	1	O-ring or 112
37	45003056	1	O-ring or 3056
38	45003087	1	O-ring or 3087
39	20030715	1	O-ring "12" SHA 65 (ST.3007) (Rev.A)
40	20080170	1	Nylon Bushing D.12 (Rev.0)
48	20080270	1	Nylon Bushing D.14 (Rev.0)

Spare Parts Kit RB 4020 2" Body

Item Number	Part Number	Qty.	Description
10	20552390	1	Diaphragm RB 4020 (2" Body) (Rev.0)
19	20604260	1	Valve Plug SHA 75 RB 4020 (2" Body) (Rev.C)
23	20556290	1	Balancing Diaphragm RB 4000 (2" Body) (II Series) (Rev.0)
31	45000108	1	O-ring or 108
32	45004312	1	O-ring or 4312
33	45004325	2	O-ring or 4325
34	45003231	1	O-ring or 3231
35	45003262	1	O-ring or 3262
36	45000112	1	O-ring or 112
37	45003056	1	O-ring or 3056
38	45003087	1	O-ring or 3087
39	20030715	1	O-ring "12" SHA 65 (ST.3007) (Rev.A)
40	20080170	1	Nylon Bushing D.12 (Rev.0)
48	20080270	1	Nylon Bushing D.14 (Rev.0)

Spare Parts Kit RB 4030 2" Body

Item Number	Part Number	Qty.	Description
10	20552390	1	Diaphragm RB 4020 (2" Body) (Rev.0)
19	20604260	1	Valve Plug SHA 75 RB 4020 (2" Body) (Rev.C)
23	20556290	1	Balancing Diaphragm RB 4000 (2" Body) (II Series) (Rev.0)
31	45000108	1	O-ring or 108
32	45004312	1	O-ring or 4312
33	45004325	2	O-ring or 4325
34	45003231	1	O-ring or 3231
35	45003262	1	O-ring or 3262
36	45000112	1	O-ring or 112
37	45003056	1	O-ring or 3056

Spare Parts Kit RB 4030 2" Body

Item Number	Part Number	Qty.	Description
38	45003087	1	O-ring or 3087
39	20030715	1	O-ring "12" SHA 65 (ST.3007) (Rev.A)
40	20080170	1	Nylon Bushing D.12 (Rev.0)
48	20080270	1	Nylon Bushing D.14 (Rev.0)

Spare Parts Kit RB 4020 3" Body

Item Number	Part Number	Qty.	Description
10	20552190	1	Diaphragm RB 4020 (3" Body) (Rev.0)
19	20601100	1	Valve Plug SHA75 RB 4020 (3" Body) (Rev.0)
23	20555390	1	Balancing Diaphragm RB 4000 (3" Body) (Rev. 0)
31	45000108	1	O-ring or 108
32	45004450	1	O-ring or 4450
33	45004475	2	O-ring or 4475
34	45004362	1	O-ring or 4362
35	45004387	1	O-ring or 4387
36	45000115	1	O-ring or 115
37	45000121	1	O-ring or 121
38	45000132	1	O-ring or 132
39	20030815	1	O-ring "14" SHA 65 (ST.3008)(Rev.A)
40	20080270	1	Nylon Bushing D.14 (Rev.0)
48	20080370	1	Nylon Bushing D.18 (Rev.0)

Spare Parts Kit RB 4030 3" Body

Item Number	Part Number	Qty.	Description
10	20552190	1	Diaphragm RB 4020 (2" Body) (Rev.0)
19	20601100	1	Valve Plug SHA75 RB 4020 (3" Body) (Rev.0)
23	20555390	1	Balancing Diaphragm RB 4000 (3" Body) (Rev.0)
31	45000108	1	O-ring or 108
32	45004450	1	O-ring or 4450
33	45004475	2	O-ring or 4475
34	45004362	1	O-ring or 4362
35	45004387	1	O-ring or 4387
36	45000115	1	O-ring or 115
37	45000121	1	O-ring or 121
38	45000132	1	O-ring or 132
39	20030815	1	O-ring "14" SHA 65 (ST.3008)(Rev.A)
40	20080270	1	Nylon Bushing D.14 (Rev.0)
48	20080370	1	Nylon Bushing D.18 (Rev.0)

Spare Parts Kit RB 4040 3" Body

Item Number	Part Number	Qty.	Description
10	20552390	1	Diaphragm RB 4020 (2" Body) (Rev.0)
19	20604260	1	Valve Plug SHA 75 RB 4020 (2" Body) (Rev.C)
23	20556290	1	Balancing Diaphragm RB 4000 (2" Body) (II Series) (Rev.0)
31	45000108	1	O-ring or 108
32	45004312	1	O-ring or 4312
33	45004325	2	O-ring or 4325
34	45003231	1	O-ring or 3231
35	45003262	1	O-ring or 3262
36	45000112	1	O-ring or 112
37	45003056	1	O-ring or 3056
38	45003087	1	O-ring or 3087
39	20030715	1	O-ring "12" SHA 65 (ST.3007) (Rev. A)
40	20080170	1	Nylon Bushing D.12 (Rev. 0)
48	20080270	1	Nylon Bushing D.14 (Rev.0)

Spare Parts Kit RB 4011-4012 3" Body

Item Number	Part Number	Qty.	Description
10	20555290	1	Diaphragm RB 4010 (3" Body) (Rev.A)
19	20600100	1	Valve Plug SHA 55 RB 4010 (3" Body) (Rev.0)
23	20555390	1	Balancing Diaphragm RB 4000 (3" Body) (Rev.0)
31	45000115	2	O-ring or 115
32	45004450	1	O-ring or 4450
33	45004475	2	O-ring or 4475
34	45004362	2	O-ring or 4362
35	45004387	1	O-ring or 4387
37	45000121	1	O-ring or 121
38	45000132	1	O-ring or 132
39	20030815	1	O-ring "14" SHA 65 (ST.3008)(Rev. A)
40	20080270	1	Nylon Bushing D.14 (Rev.0)
48	20080370	3	Nylon Bushing D.18 (Rev.0)
54	20500270	1	Cap Gasket for VDB 8600 (Rev.0)
56	48000804	1	Elastic Pin 3x20 UNI 6873
57	20600200	1	Valve Plug RB 4011 (3" Body) (Rev.B)
60	45000128	2	O-ring or 128
65	45003037	2	O-ring or 3037
109	20558290	1	Diaphragm VDB 8600 L.P. (Rev.0)
117	45004437	1	O-ring or 4437

Spare Parts Kit RB 4031-4032 3" Body

Item Number	Part Number	Qty.	Description
10	20552390	1	Diaphragm RB 4020 (2" Body) (Rev.0)
19	20601100	1	Valve Plug SHA75 RB 4020 (3" Body) (Rev.0)
23	20555390	1	Balancing Diaphragm Rb 4000 (3" Body) (Rev.0)
31	45000108	1	O-ring or 108
32	45004450	1	O-ring or 4450
33	45004475	2	O-ring or 4475
34	45004362	2	O-ring or 4362
35	45004387	1	O-ring or 4387
36	45000115	1	O-ring or 115
37	45000121	1	O-ring or 121
38	45000132	1	O-ring or 132
39	20030815	1	O-ring "14" SHA 65 (ST.3008)(Rev. A)
40	20080270	1	Nylon Bushing D.14 (Rev.0)
48	20080370	1	Nylon Bushing D.18 (Rev.0)
67	20551690	1	Shut-Off Valve Diaphragm RB 4021 (Rev.0)
72	20600200	1	Valve Plug RB 4011 (3" Body) (Rev.B)
75	45000112	1	O-ring or 112
76	45003237	1	O-ring or 3237
77	45003087	1	O-ring or 3087
78	20030415	1	O-ring "10" SHA 65 (ST.3001)(Rev.B)
85	48000804	1	Elastic Pin 3x20 UNI 6873
86	45004437	1	O-ring or 4437

Spare Parts Kit RB 4041-4042 3" Body

Item Number	Part Number	Qty.	Description
10	20552990	1	Diaphragm RB 4030 (Rev.0)
19	20601100	1	Valve Plug Sha75 RB 4020 (3" Body) (Rev.0)
23	20555390	1	Balancing Diaphragm RB 4000 (3" Body) (Rev.0)
31	45000108	1	O-ring or 108
32	45004450	1	O-ring or 4450
33	45004475	2	O-ring or 4475
34	45004362	1	O-ring or 4362
35	45004387	1	O-ring or 4387
36	45000115	1	O-ring Or 115
37	45000121	1	O-ring or 121
38	45000132	1	O-ring or 132
39	20030815	1	O-ring "14" SHA 65 (ST.3008)(Rev.A)
40	20080270	1	Nylon Bushing D.14 (Rev.0)
48	20080370	1	Nylon Bushing D.18 (Rev.0)
67	20555090	1	Shut-Off Valve Diaphragm RB 4031 (Rev.0)
72	20600200	1	Valve Plug RB 4011 (3" Body) (Rev.B)
75	45000112	1	O-ring or 112
76	45003237	1	O-ring or 3237
77	45003087	1	O-ring or 3087

Spare Parts Kit RB 4041-4042 3" Body

Item Number	Part Number	Qty.	Description
78	20030415	1	O-ring "10" SHA 65 (ST.3001)(Rev.B)
85	48000804	1	Elastic Pin 3X20 UNI 6873
86	45004437	1	O-ring or 4437

Special Tools

Part Number	Description
39926000	Orifice Wrench 2" Valve Body
39927000	Orifice Wrench 3" Valve Body
799056	Spring Adjustment Wrench

Item Number	Part Number	Spring Color
5	20568085	Orange/Silver
5	20568086	Brown/Silver
5	20568087	Dark Green/Silver
5	20568088	Light Green/Silver
5	20568089	Light Blue/Silver
5	20568090	Black/Silver
5	20568081	Purple/Silver
5	20568082	Yellow
5	20568083	Blue/Silver
5	20568183	Blue
5	20568182	Silver
5	20568181	Purple
5	20568186	Yellow/Silver
5	20568184	Red/Silver
5	20568185	White/Silver
5	20569590	Orange
5	20569591	Brown
5	20569592	Dark Green
5	20569593	Light Green
5	20569594	Black
5	20569690	Red
5	20569691	Light Blue
5	20569585	White
5	20569586	Pink

Vent Lines for Regulators

When constructing vent lines to be attached to regulators installed indoors, follow a few basic rules:

- Never use pipe sizes smaller than the vent size; smaller pipe sizes restrict the gas flow. If a long gas run must be used, Itron advises increasing the pipe one nominal size every ten feet to keep the flow restriction as low as possible.
- Keep the vent line length as short as possible to minimize the restriction and reduce the vent's tendency to cause regulator pulsation.
- Support the vent pipe to eliminate strain on the regulator diaphragm case.
- Always point outdoor vent pipes in the downward position to reduce the possibility of rain, snow, sleet, and other moisture entering the pipe. Install a bug screen in the end of the pipe.
- Do not locate the vent line terminus near windows, fans, or other ventilation equipment. See the installation instructions furnished with the regulator.
- Adhere to all applicable codes and regulations.
- If your vent pipe causes regulator pulsation, consult your sales representative or manufacturer.
- Itron strongly recommends running a separate vent line for each regulator. Headers with various installed devices can cause regulator malfunction.

Caution Ensure the end of the vent line is away from ANY potential ignition sources. It is the installer's responsibility to ensure the vent line is exhausting to a safe environment.

Installation

Warning Itron does not endorse or warrant the completeness or accuracy of any third party regulator installation procedures or practices, unless otherwise provided in writing by Itron. Follow your company's standard operating procedures regarding the use of personal protection equipment (PPE). Adhere to guidelines issued by your company in addition to those given in this document when installing regulators.

Start-up Procedure Schematic

Key

- | | |
|-----|---|
| No. | Description |
| 1 | Upstream valve |
| 2 | Differential pressure gauge |
| 3 | Strainer/Filter |
| 4 | Upstream pressure gauge |
| 5 | Regulator/Monitor |
| 6 | Shutoff valve |
| 7 | Pressure gauge |
| 8 | Monitor Regulator |
| 9 | Shutoff valve impulse |
| 10 | Regulator impulse |
| 11 | Monitor regulator impulse |
| 12 | Downstream pressure gauge |
| 13 | Discharge vent pipe |
| 14 | Downstream valve |
| 15 | Upstream isolating connection |
| 16 | Discharge vent pipe |
| 17 | Regulator vent |
| 18 | Meter |
| 19 | Peak shaving valve |
| 20 | Downstream electrical insulating connection |

Fig. 1

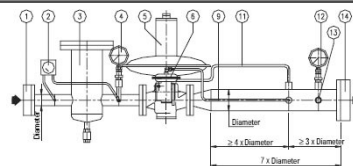

Fig. 2

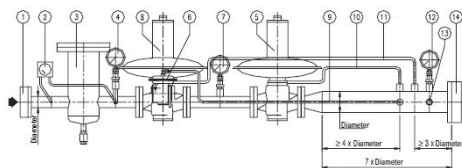

Fig. 3

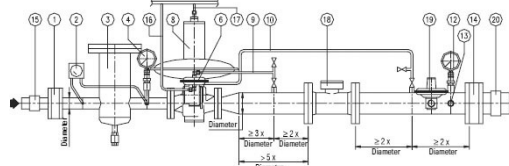
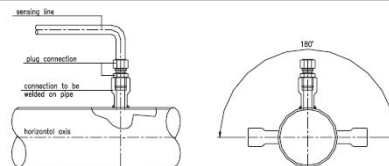

Fig. 4



Start-up Procedure

After the pressure regulator has been installed, make sure that:

- The on/off valve upstream and downstream and the discharge vent pipe are all closed
- The pressure of the inlet gas is not higher than the established design value

After these checks have been made, proceed as follows:

- Partially open the upstream on/off valve slowly just enough to make sure that a very small amount of gas passes.
- Reset the shutoff valve whenever it has been set for minimum pressure intervention because it will be closed in the absence of pressure (see the paragraph regarding the resetting of the shutoff unit).
- Check that the pressure rises slowly on the upstream and downstream pressure gauge's; the downstream pressure must stabilize around the pre-set set value or a value slightly higher (if the pressure continues to rise, interrupt the starting procedure by closing the upstream on/off valve and consult the trouble-shooting diagram to identify the cause of the malfunction).
- After the upstream pressure value has stabilized, open the upstream on/off valve completely.
- Slowly open the downstream on/off valve until the piping is completely filled.

At this point, the pressure regulator is operative. The same procedure must be used when installing monitor-equipped pressure regulators connected on line with the active pressure regulator (see Fig. 2), bearing in mind that the pressure gauge installed in the section in between the two regulators must indicate the same pressure value as the upstream gauge.

Pressure Regulator Setting (See the Principle of Operation Schematic)

The pressure regulator is usually delivered already set to the specifications indicated in the order. Whenever the set pressure must be

modified, this value must be set within the setting range of the spring installed.

After first checking the suitability of the spring installed to achieve the desired setting value, proceed as follows:

- To increase the value of the set pressure: rotate the spring adjustment ferrule (lock) nut clockwise using the adjustment wrench until the desired value is reached (which can be read on the gauge downstream).
- To decrease the value of the set pressure: proceed as above, rotating the spring adjustment ferrule counter-clockwise.
- These operations can be performed regardless of whether the pressure regulator is delivering flow or the downstream on/off cock is closed, making sure (in the latter case) to open the discharge plug (control line intake), downstream of the regulator. This valve should be closed after the desired set pressure is obtained.

Shutoff Device Setting

After first checking the suitability of the spring installed to achieve the desired set pressure, proceed as follows:

- Check the setting of the shut off unit
- To reach the maximum downstream pressure:
- Close the ON/OFF valve downstream (Fig.1) and slowly increase the pressure downstream until the desired maximum intervention pressure is reached.
- To correct this value, rotate the overpressure adjustment spring nut clockwise to increase the set pressure and counter-clockwise to decrease the value. (See the Principle of Operation Schematic)

To reach the minimum downstream pressure:

- Close the upstream ON/OFF valve (Fig. 1), and slowly discharge the downstream pressure until the desired minimum intervention pressure is reached.
- In order to correct this value rotate the under pressure adjustment spring nut (See Principle of

Operation Schematic) clockwise to increase the setting value, and counter-clockwise to decrease the value.

IMPORTANT!

The changing of the setting of the shutoff valve must always be performed with the shutoff valve diaphragm chamber under pressure. (See the Principle of Operation Schematic)

Shutoff Device Reset (Fig.1, 2 & 3)

The shutoff device must be reset only after first identifying the reason why it triggered in the first place. To restore normal operating conditions the following operations should be performed.

- Close the ON/OFF valve downstream;
- Open the valve for the upstream and downstream pressure gauges
- Downstream pressure = 0 (discharge any residual pressure by opening the discharge vent pipe).
- Relief valve and discharge valve closed
- Check the seal of the unit's valve seat by opening the discharge valve (test using bubble system):
- Slowly rotate the reset lever (See Principle of Operation Schematic) clockwise until the internal bypass is opened. This operation permits the filling of the outlet chamber, the piping downstream and the shutoff valve diaphragm chamber, which can be checked on the gauge positioned downstream
- After the pressure on the gauge has stabilized, continue using the reset lever until it can be connected to the control levers, and at this point, the reset lever will remain stable in its open position.
- After these operations have been performed, the shutoff valve will be ready for service and the downstream valve can be slowly reopened.
- When restoring normal operating conditions, the shutoff valve must always be reset whenever the valve is equipped with the minimum downstream pressure intervention function.

Safety Warning

This product, as of the date of manufacture, is designed and tested to conform to all governmental and industry safety standards as they may apply to the manufacturer. The purchaser/user of this product must comply with all fire control, building codes, and other safety regulations governing the application, installation, operation, and general use of this regulator to avoid leaking gas hazards resulting from improper installation, startup or use of this product.

Itron strongly recommends installation by a qualified professional and periodic inspection of pressure regulators (inspections may be required by local applicable codes or regulations).

Inspections should include checking for gas quality, cycle numbers, external environmental changes, and operating conditions that impact wear on the regulator's moving parts. To ensure safe and efficient operation of this product, replace worn or damaged parts found during inspection.

Limited Warranty

Itron, Inc. 970 Highway 127 North, Owenton, Kentucky 40359-9302, warrants this gas product against defects in materials and workmanship for the earlier of one (1) year from the date the product is shipped by Itron or a period of one year from the date the product is installed by Itron at the original purchaser's site. During such one-year period, provided that the original purchaser continues to own the product, Itron will, at its sole option, repair any defects, replace the product or repay the purchase price.

- > This warranty will be void if the purchaser fails to observe the procedures for installation, operation or service of the product as set forth in the Operating Manual and Specifications for the product or if the defect is caused by tampering, physical abuse or misuse of the product.
- > ITRON SPECIFICALLY DISCLAIMS ALL IMPLIED WARRANTIES INCLUDING THOSE OF MERCHANTABILITY OR OF FITNESS FOR A PARTICULAR PURPOSE. UNDER NO CIRCUMSTANCES WILL ITRON BE LIABLE FOR INCIDENTAL OR CONSEQUENTIAL DAMAGES OF ANY KIND WHATSOEVER.
- > Itron's liability for any claim of any kind, including negligence and breach of warranty for the sale and use of any product covered by or furnished, shall in no case exceed the price allocable to the product or part thereof which gives rise to the claim.

- > In the event of a malfunction of the product, consult your Itron Service Representative or Itron Inc., 970 Highway 127 North, Owenton, Kentucky 40359-9302. See Itron Terms and Conditions of Sale for the full and complete terms of the Limited Warranty.

Ordering Information

Specify:

1. Inlet and Outlet Connection Size and Type
2. Model Number
3. Outlet pressure desired
4. Pilot needed
5. Inlet pressure range
6. Type of gas and maximum capacity required
7. Assembly position number (see chart below)
8. Special requirements such as tagging, 1/8" pipe plug tap, seal wire, etc.

About Itron Inc.

At Itron, we're dedicated to delivering end-to-end smart grid and smart distribution solutions to electric, gas and water utilities around the globe. Our company is the world's leading provider of smart metering, data collection and utility software systems, with nearly 8,000 utilities worldwide relying on our technology to optimize the delivery and use of energy and water. Our offerings include electricity, gas, water and heat meters; network communication technology; collection systems and related software applications; and professional services. To realize your smarter energy and water future, start here: www.itron.com



Itron Gas

970 Highway 127 North
Owenton, Kentucky 40359
USA
Phone: 1.800.490.0657
1.502.484.5747
fax: 1.502.484.6223

Corporate Headquarters

2111 North Molter Road
Liberty Lake, WA 99019
USA
Phone: 1.800.635.5461
Fax: 1.509.891.3355
www.itron.com