



RB4000 Series

Commerical & Industrial Regulator

- ▶ Reduced overall dimensions/high capacity
- ▶ Easy maintenance
- ▶ Boosting mechanism gives “fixed-factor” regulation for industrial application
- ▶ Rugged construction for durability
- ▶ Balanced valve design eliminates inlet pressure effect
- ▶ Fast-acting for sharp On-Off Loads



Applications

The Series RB4000 pressure regulator is designed for gas supply networks, district station regulation, industrial service regulation, and all applications where accurate pressure control, ease of adjustment, and fast response are required such as for burners, industrial ovens, boilers, etc.

Features

- Direct acting spring-loaded pressure regulator
- Balanced Valve Design
- Fluids: Natural gas, propane, butane, air, nitrogen, etc.
- Built-in pulsation damper
- Suited for both vertical and horizontal applications
- Available with silencer
- Available with High and/or Low pressure shut-off valve
- Built-in bypass system for ease of shut-off reset

Operating Sketch

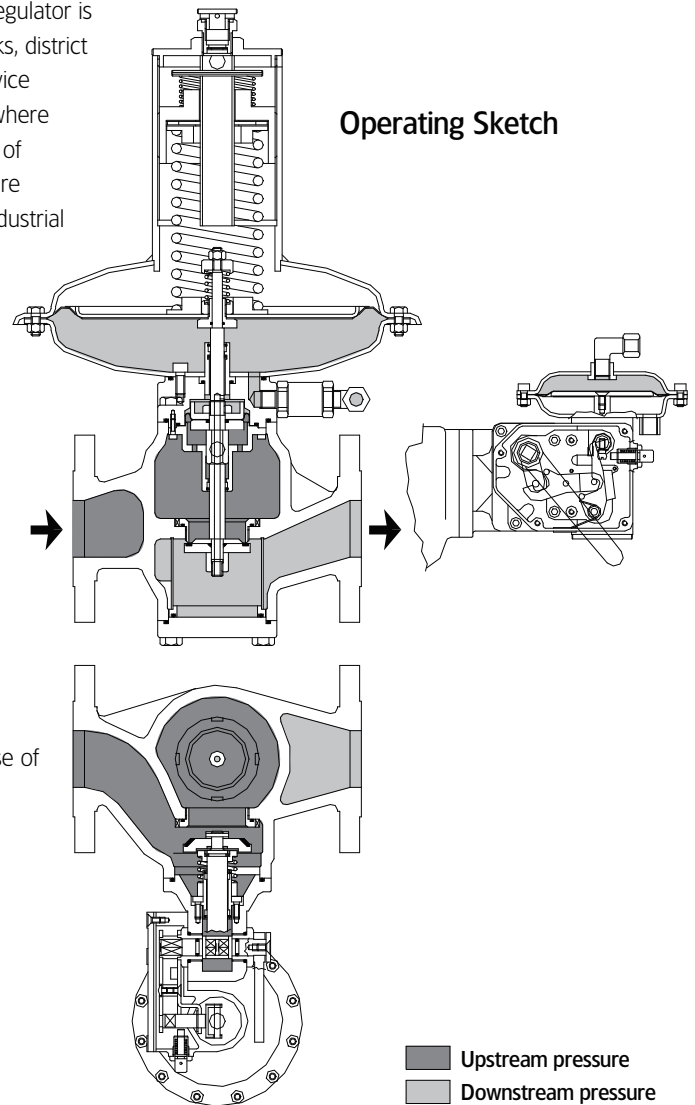

Correction factors for non-natural gas applications:

The RB4000 may be used to control materials other than natural gas. To determine the capacity of the RB4000 for gases other than natural gas, it will be necessary to multiply the values within the capacity tables by a correction factor.

The table below lists the correction factors for some of the more common gases:

Gas Type	Specific Gravity	Correction Factor (CF)
Air	1.00	0.77
Butane	2.01	0.55
Carbon Dioxide (Dry)	1.52	0.63
Carbon Monoxide (Dry)	0.97	0.79
Natural Gas	0.60	1.00
Nitrogen	0.97	0.79
Propane	1.53	0.63
Propane-Air-Mix	1.20	0.71

To calculate the correction factor for gases not listed on the table above, it will be necessary to know the specific gravity of the gas and use it in the formula listed below:

$$\text{Correction Factor (CF)} = \sqrt{\frac{SG_1}{SG_2}}$$

Where:

- SG₁ = Specific Gravity of the gas in which the capacity is published.
 SG₂ = Specific Gravity of the gas to be controlled.

Construction

Actaris takes pride in delivering American made products with the utmost concern for safety, quality and customer satisfaction.

Material Construction:

Body:	Ductile iron quality 500-7 UNI-ISO 1083, Steel quality ASTM A 216 WCB
Internal Parts:	Brass and stainless steel
Diaphragm:	Synthetic rubber with fabric reinforcement
Seals:	Nitrile rubber or Viton (on request)
Diaphragm Casing & Cover:	UNI/EN 10025 pressed steel

Shipping Weight:

Regulator per box: 1 121 lbs.

Version Selection - RB4000	4	0	X	X	Valve Body	Version
					1	Low pressure
					2	Medium pressure
					3	High pressure
					4	High pressure (only for 3")
				0		Without shutoff valve
				1		With over pressure shutoff valve**
				2		With over and under pressure shut-off valve**
					2" Flange*	
					3" Flange*	

*Please specify valve body material on your order (Ductile Iron or Steel).

**Multiply capacity data by 0.7 when using shut-off valve versions.

► Valve Body Sizes

Inlet	Outlet	Flanged	Orifice Size	Wide Open
2"	2"	X	2"	4430
3"	3"	X	3"	8540

x - indicates that the valve body is available in that configuration.

Wide-Open Flow Calculations

For wide-open orifice flow calculations use the following equations:

For $P_1/P_2 \leq 1.89$ use: $Q_{max} = K \sqrt{P_2 (P_1 - P_2)}$ For $P_1/P_2 \geq 1.89$ use: $Q_{max} = \frac{KP_1}{2}$

Where: P_1 = absolute inlet pressure (psia) P_2 = absolute outlet pressure (psia)
 Q = flow rate (scfh) K = orifice coefficient (scfh/psia)

Specifications

RB4000 Dimensions

Valve Body Size	Inches	Without Built-in Shut-off Valve			With Built-in Shut-off Valve		
	Dimension	RB4010	RB4020	RB4030-40	RB4011-12	RB4021-22	RB4031-32
2"	A	10	10	10	10	10	10
	B	22.2	21.3	21.3	22.2	21.3	21.3
	C	3.9	3.9	3.9	3.9	3.9	3.9
	D	18.9	14.2	14.2	18.9	14.2	14.2
	E	--	--	--	12.0	12.0	10.9
	F	--	--	--	5.9/3.5	5.9/3.5	5.9/3.5
	G	--	--	--	5.7	5.7	5.7
	Weight (lb)		90.4	63.9	72.8	105.8	77.2
3"	A	11.7	11.7	11.7	11.7	11.7	11.7
	B	28.0	25.8	24.6	28.0	25.8	24.6
	C	5.1	5.1	5.1	5.1	5.1	5.1
	D	23.6	18.9	14.2	23.6	18.9	14.2
	E	--	--	--	14.3	14.3	13.1
	F	--	--	--	5.9/3.5	5.9/3.5	5.9/3.5
	G	--	--	--	7.3	7.3	7.3
	Weight (lb)		154.3	123.5	108.0	178.6	147.7

► RB4000 Dimensions

Figure 1

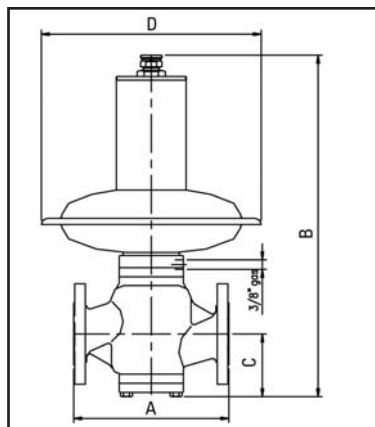

Without Built-in Shut-off Valve

Figure 2

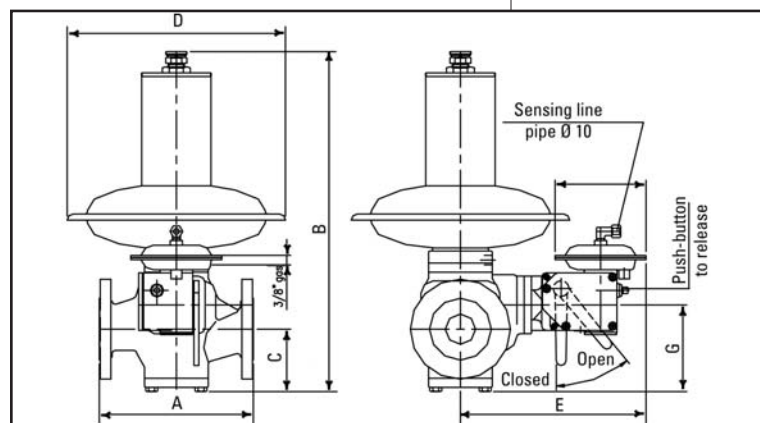

With Built-in Shut-off Valve

RB4000 Spring Ranges: 2" Valve Body

Part Number	Spring Color	RB4010			RB4020			RB4030		
		Spring Range ("w.c./PSIG)		4010 Basic Set Point	Spring Range ("w.c./PSIG)		4020 Basic Set Point (PSIG)	Spring Range ("w.c./PSIG)		4030 Basic Set Point (PSIG)
20568085	Orange/Silver	4.1	5.8	5" w.c.	11	14	14" w.c.	--	--	--
20568086	Brown/Silver	5.8	7.8	7" w.c.	13.8	18.3	--	--	--	--
20568087	Dark Green/Silver	7.8	10.7	9" w.c.	18.5	25	--	--	--	--
20568088	Light Green/Silver	10.3	14.8	14" w.c.	22.8	32	--	--	--	--
20568089	Light Blue/Silver	14.4	19.8	--	0.9	1.3	1 PSIG	--	--	--
20568090	Black/Silver	18.5	25.9	21" w.c.	1.7	2.3	2 PSIG	--	--	--
20568081	Purple/Silver	0.8	1.3	1 PSIG	1.6	2.6	--	--	--	--
20568082	Yellow	1.2	1.9	--	2.6	4.1	3 PSIG	--	--	--
20568083	Blue/Silver	1.6	2.1	2 PSIG	4.1	5.4	5 PSIG	--	--	--
20568183	Blue	--	--	--	3.9	6.5	--	--	--	--
20568182	Silver	--	--	--	6.4	8.5	--	8.7	12.8	10.0
20568181	Purple	--	--	--	7.0	10.0	--	10.2	14.8	--
20568186	Yellow/Silver	--	--	--	9.4	11.6	10 PSIG	11.6	17.7	15
20568184	Red/Silver	--	--	--	11.6	16.0	15 PSIG	17.4	23.9	20
20568185	White/Silver	--	--	--	14.5	18.8	--	20.3	30.5	25, 30

RB4000 Spring Ranges: 3" Valve Body

Part Number	Spring Color	RB4020			RB4030			RB4040		
		Spring Range ("w.c./PSIG)		4020 Basic Set Point	Spring Range ("w.c./PSIG)		4030 Basic Set Point (PSIG)	Spring Range (PSIG)		4040 Basic Set Point (PSIG)
20568085	Orange/Silver	4.1	5.8	5" w.c.	11	14	14" w.c.	--	--	--
20568086	Brown/Silver	5.8	7.8	7" w.c.	13.8	18.3	--	--	--	--
20568087	Dark Green/Silver	7.8	10.7	9" w.c.	18.5	25	--	--	--	--
20568088	Light Green/Silver	10.3	14.8	14" w.c.	22.8	32	--	--	--	--
20568089	Light Blue/Silver	14.4	19.8	--	0.9	1.3	1 PSIG	--	--	--
20568090	Black/Silver	18.5	25.9	21" w.c.	1.7	2.3	2 PSIG	--	--	--
20568081	Purple/Silver	0.8	1.3	1 PSIG	1.6	2.6	--	--	--	--
20568082	Yellow	1.2	1.9	--	2.6	4.1	3 PSIG	--	--	--
20568083	Blue/Silver	1.6	2.1	2 PSIG	4.1	5.4	5 PSIG	--	--	--
20568183	Blue	1.7	3.5	3.0 PSIG	3.9	6.5	--	--	--	--
20568182	Silver	2.6	4.2	--	6.4	8.5	--	--	--	--
20568181	Purple	3.5	5.4	5 PSIG	7.0	10.0	--	10.2	14.8	10
20568186	Yellow/Silver	4.4	6.8	--	9.4	11.6	10 PSIG	11.6	17.7	15
20568184	Red/Silver	5.5	7.3	--	11.6	16.0	15 PSIG	17.4	23.9	20
20568185	White/Silver	--	--	--	14.5	18.8	--	20.3	30.5	25, 30

RB4000 Overpressure Shut-off Valve Spring Ranges

Part Number	Spring Color	Shut-off Models 8611 and 8612		Shut-off Models 8621 and 8622		Shut-off Models 8631 and 8632		Shut-off Models 8641 and 8642	
		6" Diaphragm (in. w.c.)		6" Diaphragm (PSIG)		3.5" Diaphragm (PSIG)		3.5" Diaphragm (PSIG)	
20565233	Yellow	11	26	1.74	3.19	2.90	5.51	4.64	8.41
20565234	Red	18	40	2.32	5.08	4.06	8.70	7.25	13.05
20565330	White	32	64	3.19	7.40	5.80	11.60	10.15	17.40
20565331	Blue	40	100	5.08	10.88	8.70	16.68	14.50	26.83
20565332	Orange	76	181	7.98	18.13	13.78	29.73	21.75	45.68
20565333	Brown	141	281	14.50	29.73	21.75	45.68	33.35	73.95
20565334	Green	181	350	21.75	36.25	29.00	55.10	44.95	84.10
20565430	Black	241	422	24.65	40.60	36.25	69.60	55.10	98.60
20565431	Gray	382	563	38.43	62.35	56.55	91.35	82.65	134.85
20565432	Yellow	--	--	--	--	72.50	116.00	130.50	188.50
20565134	Red	--	--	--	--	111.65	156.60	184.15	217.50

RB4000 Underpressure Shut-off Valve Spring Ranges

Part Number	Spring Color	Shut-off Model 8612		Shut-off Model 8622		Shut-off Model 8632		Shut-off Model 8642	
		6" Diaphragm (in. w.c.)		6" Diaphragm (PSIG)		3.5" Diaphragm (PSIG)		3.5" Diaphragm (PSIG)	
20561124	White	2	7	--	--	--	--	--	--
20561221	Blue	4	22	--	--	--	--	--	--
20561222	Orange	12	30	1.60	4.21	3.34	7.11	4.64	9.14
20561223	Brown	24	60	2.32	7.11	3.77	10.59	6.09	15.95
20561224	Green	84	297	4.64	14.50	7.54	14.50	7.54	22.48

RB4000 Operating Principle

The fluid from the upstream pipe enters the inlet chamber (8), passes through the opening in the valve seat (29) and (7), expands in the outlet chamber (11) and then enters the downstream pipe. The pressure of the gas is sensed downstream via the control line, and passes through the port (13) before entering the control chamber (14). This pressure exerts a force on the surfaces of the diaphragm (15) that balances the calibration spring (2) load for the ideal positioning of the valve plug (10) required to guarantee the requested flow and downstream regulation. If, during operation, the flow increases due to a greater demand or the upstream pressure decreases, the pressures in the chambers (11) and (14) immediately drop and the calibration spring (2) moves the diaphragm unit (15), the stem (6) and the valve plug (10) downwards, thereby modifying the adjustment position to give the required pressure and flow values.

The reverse action occurs whenever the flow decreases or if the upstream pressure increases. In this case, the pressure regulator's adjustment unit is balanced, and this permits the annulment of any negative forces created as a result of the change in the pressure upstream in order to guarantee a constant outlet pressure. At zero flowrate the regulator guarantees full tightness in lock-up.

Shutoff Valve Operation

The shutoff valve is composed of the pressure switch for pressure comparison (23), the control levers (24) and the shut off valve plug (25). The shutoff valve is triggered whenever the pressure in the control chamber (19) increases or decreases beyond the established values. This is achieved when the diaphragm unit (20) moves from the unbalanced position and trip the control levers (24) to release the shutoff valve (25). Under the force generated by the spring (28), the shutoff valve (25) is brought into contact with the valve seat (29) and immediately interrupts the flow of gas.

Monitor application (See Page 11, Fig. 5)

The monitor regulator intervenes whenever the main active pressure regulator malfunctions (e.g. fails open), and causes the downstream pressure to rise to the set pressure of the monitor regulator.

Fig. 3

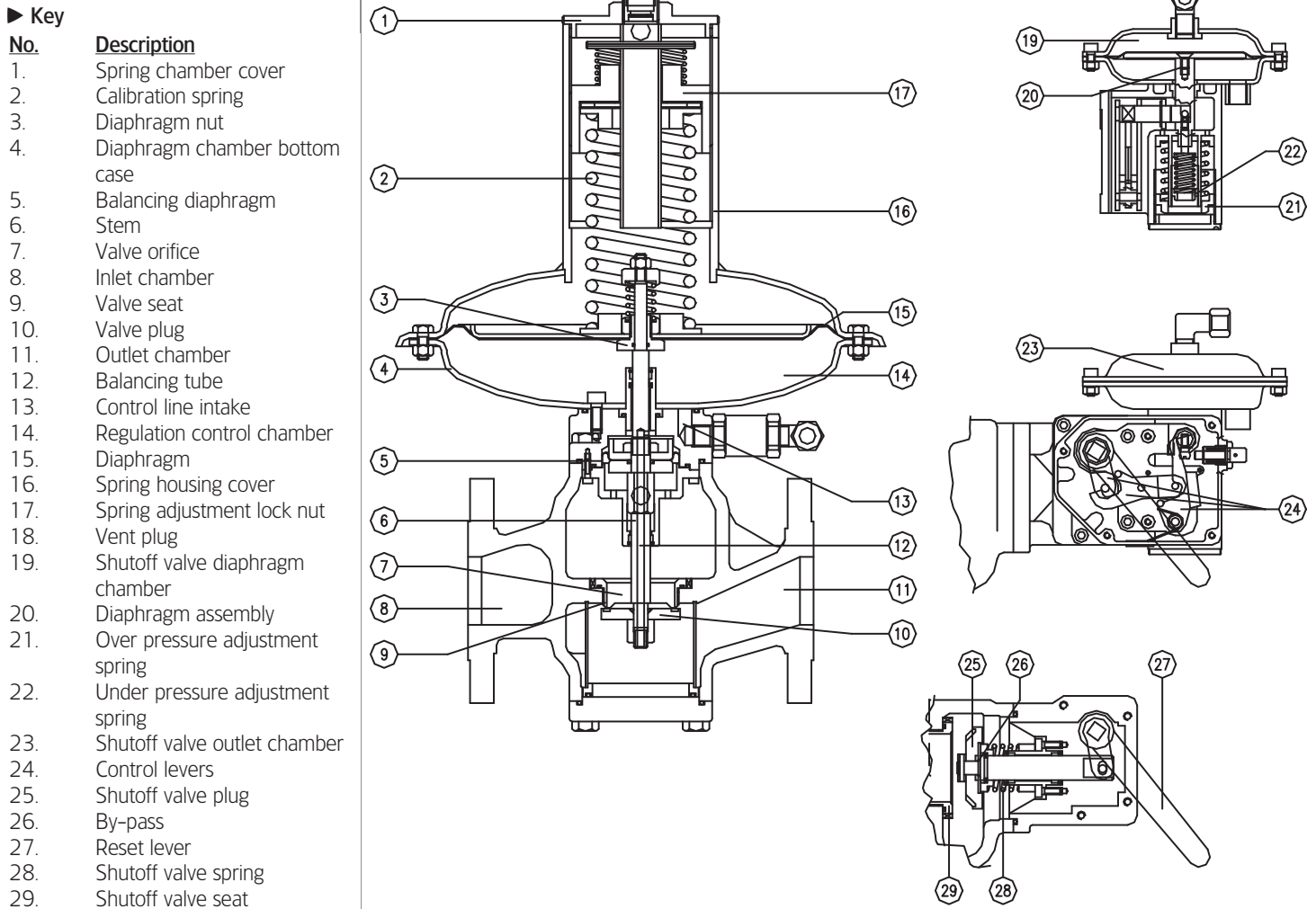

RB4000 Commercial & Industrial Regulator

2" RB4010 Capacity Table*

Inlet Pressure		Capacities in mcfh of 0.6 S.G. Natural Gas					
		Outlet Pressure Setting					
		7" w.c.		14" w.c.		1 PSIG	
		1" w.c. droop	2" w.c. droop	1% absolute droop	2% absolute droop	1% absolute droop	2% absolute droop
1	PSIG	14.2					
2	PSIG	18.0	17.5	16.0	17.0		
3	PSIG	23.5	25.0	22.5	25.7	10.3	17.8
5	PSIG	38.0	34.3	32.5	38.3	16.3	28.6
8	PSIG	43.9	38.9	33.5	43.9	22.7	39.9
10	PSIG	47.9	55.8	56.3	64.3	26.2	47.5
15	PSIG	57.4	75.6	56.1	64.1	32.6	57.5
20	PSIG	67.0	94.8	65.5	74.8	40.7	67.0
30	PSIG	86.2	96.2	84.4	96.4	45.5	79.0
40	PSIG	105.4	99.6	103.3	118.0	52.8	98.2
50	PSIG	124.6	117.9	122.2	139.6	58.5	120.6
60	PSIG	143.8	136.1	141.0	161.1	77.3	139.3
70	PSIG	162.9	154.3	159.9	182.7	87.7	158.0
80	PSIG	182.1	172.5	178.8	204.3	98.1	176.7
90	PSIG	201.3	190.7	197.7	225.8	108.5	195.4
100	PSIG	220.5	208.9	216.6	247.4	118.9	214.2
120	PSIG	261.2	245.4	254.3	290.5	139.7	251.6
150	PSIG	316.4	566.4	311.0	355.2	170.8	307.8
175	PSIG	364.3	652.4	358.2	409.2	196.8	354.6
200	PSIG	412.3	738.4	405.4	463.1	222.8	401.4
225	PSIG	460.2	824.4	452.6	517.0	248.8	448.1
Increase in outlet pressure above set point required for no flow		1" w.c.	1.5" w.c.	0.1 PSIG		0.2 PSIG	

2" RB4020 Capacity Table*

Inlet Pressure		Capacities in mcfh of 0.6 S.G. Natural Gas							
		Outlet Pressure Setting							
		1 PSIG		2 PSIG		5 PSIG		10 PSIG	
		1% absolute droop	1% absolute droop	2% absolute droop	1% absolute droop	2% absolute droop	1% absolute droop	10% gauge droop	20% gauge droop
1	PSIG								
2	PSIG	15.2							
3	PSIG	19.7	10.3	17.8					
5	PSIG	27.2	16.3	28.6					
8	PSIG	34.8	22.7	39.9	16.0	23.6			
10	PSIG	38.2	26.2	47.5	20.8	28.9			
15	PSIG	46.2	32.6	57.5	30.8	46.4	17.8	34.8	50.8
20	PSIG	52.4	40.7	67.0	36.6	49.4	24.9	47.6	69.1
30	PSIG	68.1	45.5	79.0	43.5	62.8	35.9	68.0	98.2
40	PSIG	87.2	52.8	98.2	53.8	76.4	44.4	85.2	121.0
50	PSIG	100.3	58.5	120.6	63.6	90.4	50.0	92.6	133.3
60	PSIG	115.9	77.3	139.3	70.5	97.4	65.4	117.3	166.6
70	PSIG	131.5	87.7	158.0	83.4	118.5	65.5	121.3	174.6
80	PSIG	147.1	98.1	176.7	93.3	132.5	73.2	135.7	195.3
90	PSIG	162.6	108.5	195.4	94.4	134.0	89.9	157.6	225.3
100	PSIG	178.2	118.9	214.2	113.0	160.6	88.8	164.4	236.7
120	PSIG	211.4	141.0	251.6	121.0	188.7	105.4	193.2	278.1
150	PSIG	256.1	170.8	307.8	126.8	191.0	131.4	213.0	315.3
175	PSIG	295.1	196.8	354.6	139.6	203.0	146.9	232.3	349.9
200	PSIG	334.0	222.8	401.4	211.9	301.0	166.3	308.2	443.6
225	PSIG	372.9	248.8	448.1	236.6	336.1	185.7	344.1	495.3
Increase in outlet pressure above set point required for no flow		0.2 PSIG	0.3 PSIG		0.3 PSIG		0.5 PSIG		

*Individual regulator performance may vary from data shown.

RB4000 Commercial & Industrial Regulator

2" RB4030 Capacity Table*

Inlet Pressure		Capacities in mcfh of 0.6 S.G. Natural Gas							
		Outlet Pressure Setting							
		10 PSIG		15 PSIG		20 PSIG		30 PSIG	
		10% gauge droop	20% gauge droop	10% gauge droop	20% gauge droop	10% gauge droop	20% gauge droop	10% gauge droop	20% gauge droop
15	PSIG	29.0	49.5						
20	PSIG	36.0	70.0	34.9	57.8				
30	PSIG	59.2	89.0	58.9	88.2	49.8	87.5		
40	PSIG	70.6	115.5	73.0	114.0	69.6	120.0	49.3	85.5
50	PSIG	78.0	123.3	77.0	121.6	84.7	136.8	59.8	110.8
60	PSIG	90.4	144.2	89.4	141.2	98.3	158.8	69.4	128.6
70	PSIG	102.9	162.9	97.3	146.2	115.9	181.7	80.4	151.1
80	PSIG	113.1	180.2	114.2	180.3	125.5	202.8	88.6	164.2
90	PSIG	121.6	199.3	126.6	199.9	139.1	224.8	98.2	182.0
100	PSIG	133.2	214.5	138.0	221.6	163.2	250.2	107.9	199.8
120	PSIG	159.5	250.1	160.4	255.3	186.7	292.8	127.1	235.5
150	PSIG	184.4	303.0	189.1	314.0	223.2	352.0	155.9	302.9
175	PSIG	214.1	357.1	231.9	366.1	254.8	411.8	180.0	333.4
200	PSIG	260.3	419.9	262.9	415.0	288.8	466.8	204.0	378.0
225	PSIG	291.0	469.4	293.8	463.9	322.8	521.7	228.0	422.5
Increase in outlet pressure above set point required for no flow		0.5 PSIG		0.8 PSIG		0.9 PSIG		1.3 PSIG	

3" RB4020 Capacity Table*

Inlet Pressure		Capacities in mcfh of 0.6 S.G. Natural Gas					
		Outlet Pressure Setting					
		1 PSIG		3 PSIG		5 PSIG	
		1% absolute droop	2% absolute droop	1% absolute droop	2% absolute droop	1% absolute droop	2% absolute droop
3	PSIG	44.3	50.6				
5	PSIG	64.0	75.4	32.1	46.2		
8	PSIG	66.0	86.5	44.7	64.4	31.5	46.5
10	PSIG	110.9	126.7	51.6	74.3	41.0	56.9
15	PSIG	110.5	126.2	64.2	92.5	60.6	91.3
20	PSIG	129.1	147.4	80.2	115.5	72.1	97.3
30	PSIG	166.3	189.9	89.6	129.1	85.7	123.7
40	PSIG	203.4	232.4	104.0	149.8	105.9	150.5
50	PSIG	240.6	274.9	115.2	166.0	125.4	178.1
60	PSIG	277.8	317.4	152.3	219.3	138.9	191.9
70	PSIG	315.0	359.9	172.8	248.8	164.3	233.5
80	PSIG	352.2	402.4	193.2	278.3	183.8	261.1
90	PSIG	389.4	444.9	213.7	307.8	186.0	264.0
100	PSIG	426.6	487.4	234.2	337.2	222.7	316.4
120	PSIG	501.0	572.4	275.1	396.2	238.4	371.8
150	PSIG	612.6	699.8	336.5	484.6	249.8	376.3
175	PSIG	705.6	806.1	387.7	558.3	275.0	399.9
200	PSIG	798.5	912.3	438.9	632.0	417.4	593.0
225	PSIG	891.5	1,018.5	490.1	705.7	466.0	662.2
Increase in outlet pressure above set point required for no flow		0.1 PSIG		0.2 PSIG		0.35 PSIG	

RB4000 Commercial & Industrial Regulator

3" RB4030 Capacity Table*

Inlet Pressure		Capacities in mcfh of 0.6 S.G. Natural Gas			
		Outlet Pressure Setting			
		10 PSIG		15 PSIG	
		10% gauge droop	20% gauge droop	10% gauge droop	20% gauge droop
15	PSIG	57.1	97.5		
20	PSIG	70.9	137.9	68.8	113.9
30	PSIG	116.6	175.3	116.0	173.8
40	PSIG	139.1	227.5	143.8	224.6
50	PSIG	153.7	242.9	151.8	239.6
60	PSIG	178.1	284.1	176.2	278.2
70	PSIG	202.7	320.9	191.7	288.0
80	PSIG	222.8	355.0	225.0	355.2
90	PSIG	239.6	392.6	249.4	393.7
100	PSIG	262.4	422.6	271.9	436.6
120	PSIG	314.2	492.7	316.0	502.9
150	PSIG	363.3	596.9	372.5	618.6
175	PSIG	421.8	703.5	456.8	721.2
200	PSIG	512.8	827.2	517.8	817.5
225	PSIG	573.3	924.7	578.8	913.9
Increase in outlet pressure above set point required for no flow		0.5 PSIG		0.8 PSIG	

3" RB4040 Capacity Table*

Inlet Pressure		Capacities in mcfh of 0.6 S.G. Natural Gas							
		Outlet Pressure Setting							
		10 PSIG		15 PSIG		20 PSIG		30 PSIG	
		10% gauge droop	20% gauge droop	10% gauge droop	20% gauge droop	10% gauge droop	20% gauge droop	10% gauge droop	20% gauge droop
15	PSIG	52.0	88.7						
20	PSIG	67.4	131.0	63.3	104.8				
30	PSIG	106.1	159.6	109.1	163.3	98.1	172.4		
40	PSIG	132.1	216.2	132.3	206.6	137.1	236.4	97.1	168.4
50	PSIG	139.8	221.0	142.7	225.3	166.8	269.5	117.8	218.3
60	PSIG	169.2	269.9	162.1	255.9	193.6	312.9	136.7	253.3
70	PSIG	184.5	292.0	180.2	270.7	228.3	357.9	158.4	297.7
80	PSIG	211.7	337.2	207.0	326.8	247.2	399.5	174.6	323.5
90	PSIG	218.0	357.3	234.4	370.1	274.0	442.9	193.5	358.6
100	PSIG	249.3	401.4	250.1	401.6	321.5	492.9	212.5	393.7
120	PSIG	285.9	448.4	297.0	472.8	367.8	576.8	250.3	463.9
150	PSIG	345.1	567.1	342.7	569.1	439.7	693.4	307.2	596.7
175	PSIG	383.8	640.2	429.4	677.9	501.9	811.2	354.5	656.9
200	PSIG	487.2	785.8	476.4	752.1	569.0	919.5	401.8	744.6
225	PSIG	521.7	841.4	544.1	859.0	636.0	1,027.8	449.2	832.3
Increase in outlet pressure above set point required for no flow		0.6 PSIG		1.0 PSIG		1.1 PSIG		1.5 PSIG	

Installation

Before installing the pressure regulator in the piping, the following must be checked:

- the upstream and downstream flanges must be parallel and the pressure regulating unit must be capable of being fitted without undue stress.
- the upstream piping must be cleaned from all impurities (sand, welding slag, etc.)
- the pressure regulator must not be visibly damaged.
- the inlet and outlet chambers of the pressure regulator must be perfectly clean.

After these checks have been made, the unit can be installed in the piping, making sure that the direction of gas flow corresponds to the arrow on the pressure regulator's body. We recommend performing installation with the valve body in horizontal alignment.

The following are also recommended:

- An electrically insulating joint upstream and

downstream, if the incoming and outgoing piping is made with ferrous material.

- An ON/OFF valve upstream and downstream of the pressure regulator.
- A manometer or pressure gauge upstream and downstream from the pressure regulator.
- An upstream filter.
- A relief valve downstream for start-up and changes in pressure setting
- A relief valve for accidental over-pressure (example: the exposure of the downstream piping to direct sunlight at zero flow).
- Free passage for maintenance operations
- In the case of an ON/OFF gas load, the downstream volume must be greater than 1ft³ per 1000 ft³/hr. of flowrate.

All variations in diameter downstream must be performed progressively in order to prevent negative turbulence.

Avoid locating the control line piping:

- Near sources of heat
- Direct sun light.

The pressure regulator's control line must be connected to the downstream pipe. These connections must be inserted in a straight section of the downstream piping as indicated in the installation diagrams (Figures 4, 5, 6).

For this purpose, we recommend welding the control line connections on the upper part of the piping in order to prevent impurities and condensation from collecting and obstructing the passage of the gas. It is also important to make sure that the control line piping slopes slightly downwards to the pipe (Fig. 7). For adequate operation, the gas velocity at the control line position in the pipe, must not exceed those given below:

Low pressure

< 2.9 PSIG: 50-65 ft/s

Med/high pressure

> 2.9 PSIG: 65-130 ft/s

Vent Lines for Regulators

When constructing vent lines to be attached to regulators installed indoors, a few basic rules must be followed:

1. Never use pipe sizes smaller than the vent size itself; anything smaller will restrict the flow of gas. If a long run must be used, it is advisable to increase the pipe one size every ten feet in order to keep the flow restriction as low as possible.
2. Keep the length of vent line as short as possible to minimize the restriction as well as reduce the tendency for the vent piping to cause pulsation of the regulator.
3. Support the vent pipe so there is no strain on the regulator diaphragm case.
4. Always point the end of the vent pipe located outside the building in the downward position to reduce the possibility of rain, snow, sleet etc. from entering the pipe. A bug screen should be installed in the end of the pipe.
5. The terminus of the vent line must not be located near windows, fans, etc. See the installation instructions furnished with the regulator.
6. All applicable codes and regulations must be adhered to.
7. Vent pipe may cause regulator pulsation. If this situation occurs, please consult your regulator representative or the factory.
8. It is strongly recommended that a separate vent line be run for each regulator; a header with other devices installed in it can cause regulator malfunction.
9. If approved by the authority having jurisdiction, the vent lines may be manifolded in accordance with accepted engineering practices to minimize backpressure in the event of diaphragm failure.

RB4000

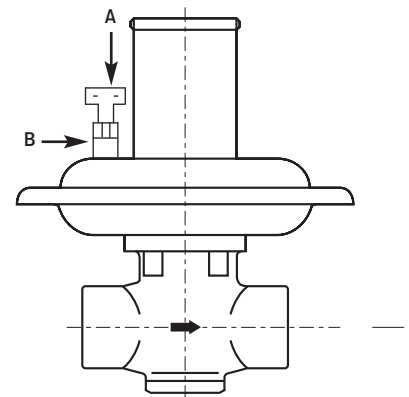

NOTE:

To install 1/4" vent pipe into the upper casing of the pressure regulator, the breather cap "A" will need to be removed. Do not remove the diaphragm breather assembly "B". The vent pipe is necessary in case of diaphragm failure.

Fig. 4

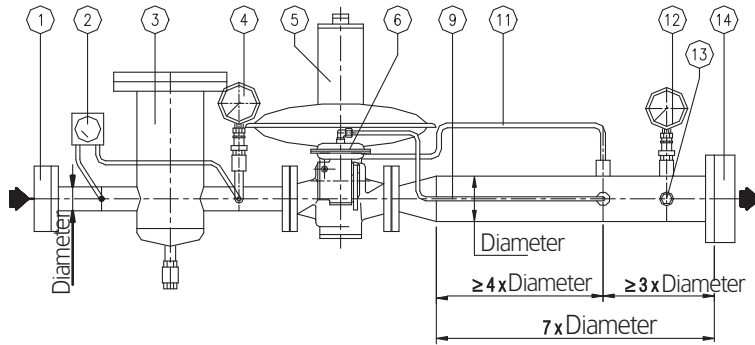

Fig. 5

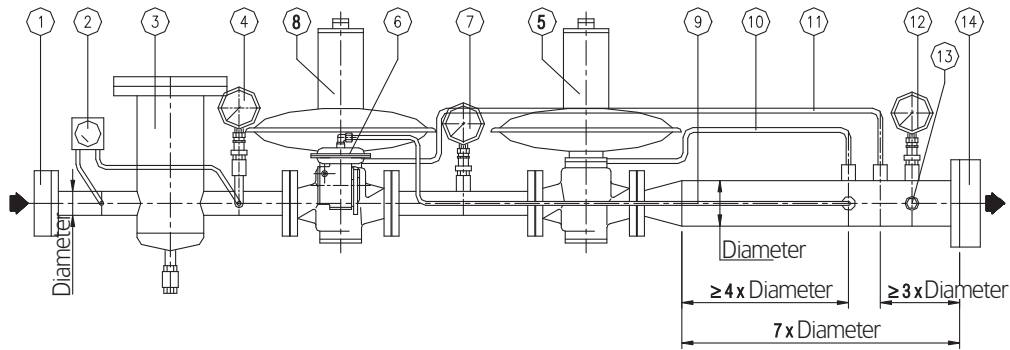

Fig. 6

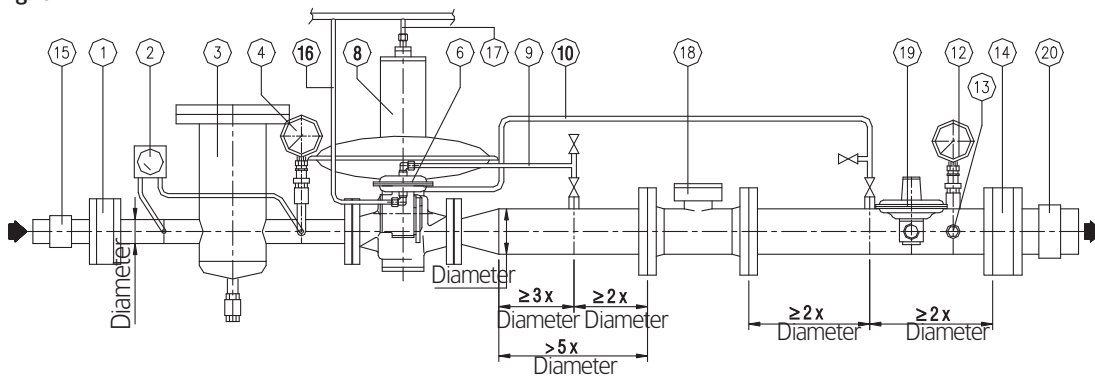
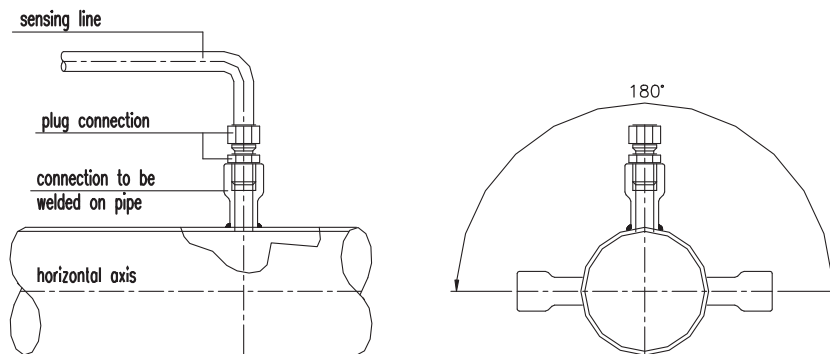

Fig. 7



Key

1. Upstream valve
2. Differential pressure gauge
3. Strainer/Filter
4. Upstream pressure gauge
5. Regulator/Monitor
6. Shutoff valve
7. Pressure gauge
8. Monitor Regulator
9. Shutoff valve impulse
10. Regulator impulse
11. Monitor regulator impulse
12. Downstream pressure gauge
13. Discharge vent pipe
14. Downstream valve
15. Upstream isolating connection
16. Discharge vent pipe
17. Regulator vent
18. Meter
19. Peak shaving valve
20. Downstream electrical

Start-Up

After the pressure regulator has been installed, make sure that:

- the on/off valve upstream (1) and downstream (14) and the discharge vent pipe (13) are all closed;
- the pressure of the inlet gas is not higher than the established design value.

After these checks have been made, proceed as follows:

- partially open the upstream on/off valve (1) slowly just enough to make sure that a very small amount of gas passes;
- reset the shutoff valve whenever it has been set for minimum pressure intervention because it will be closed in the absence of pressure (see the paragraph regarding the resetting of the shutoff unit);
- check that the pressure rises slowly on the gauges (4) and (12); the downstream pressure must be stabilized around the pre-set value or a value slightly higher (if the pressure continues to rise, interrupt the starting procedure by closing the on/off valve (1) and consult the trouble-shooting diagram to identify the cause of the malfunction);
- after the upstream pressure value has stabilized, open the on/off valve (1) completely;
- then slowly open the downstream on/off valve (14) until the piping is completely filled.

At this point, the pressure regulator is operative. The same procedure must be used when installing monitor-equipped pressure regulators connected on line with the active pressure regulator (see Fig. 5), bearing in mind that the gauge (7) installed in the section in between the two regulators must indicate the same pressure value as the upstream gauge (4).

Pressure Regulator Setting (Fig.3)

The pressure regulator is usually delivered already set to the specifications indicated in the order. Whenever the set pressure must be modified, this value must be set within the setting range of the spring installed.

After first checking the suitability of the spring installed to achieve the desired setting value, proceed as follows:

• **To increase the value of the set pressure:**
Rotate the spring adjustment ferrule nut (17) clockwise using the adjustment wrench until the desired value is reached (which can be read on the gauge downstream).

• **To decrease the value of the set pressure:**
Proceed as above, rotating the spring adjustment ferrule counter-clockwise.

These operations can be performed regardless of whether the pressure regulator is delivering flow or the downstream on/off cock is closed, making sure (in the latter case) to open the discharge plug (13), downstream of the regulator. This valve should be closed after the desired set pressure is obtained.

Shutoff Device Setting

After first checking the suitability of the spring installed to achieve the desired set pressure, proceed as follows:

Check the setting of the shutoff unit:

• **To reach the maximum downstream pressure:**
Close the ON/OFF valve downstream 14 (Fig.4) and slowly increase the pressure downstream until the desired maximum intervention pressure is reached. In order to correct this value, rotate the spring adjustment lock nut 21 (Fig.3) clockwise to increase the set pressure and counter-clockwise to decrease the value.

• **To reach the minimum downstream pressure:**
Close the upstream ON/OFF valve 1 (Fig. 4), and slowly discharge the downstream pressure until the desired minimum intervention pressure is reached.

In order to correct this value, rotate the spring adjustment lock nut 22 (Fig.3) clockwise to increase the setting value, and counter-clockwise to decrease the value.

IMPORTANT!

The changing of the setting of the shutoff valve must always be performed with the diaphragm control chamber 19 (Fig. 3) under pressure.

Shutoff Device Reset (Fig.4, 5 & 6)

The shutoff device must be reset only after first identifying the reason why it triggered in the first place. To restore normal operating conditions the following operations should be performed:

- Close the ON/OFF valve downstream (14);
- Open the valve for the gauges 4 and 12;
- Downstream pressure = 0 (discharge any residual pressure by opening the discharge vent pipe 13);
- Relief valve and discharge valve closed;
- Check the seal of the unit's valve seat by opening the discharge valve (13) (test using bubble system):

- slowly rotate the reset lever 27 (Fig.3) clockwise until the internal bypass 26 (Fig. 3) is opened. This operation permits the filling of the outlet chamber (11), the piping downstream and the control chamber 19 (Fig. 3) , which can be checked on the gauge positioned downstream ;
- after the pressure on the gauge has stabilized, continue using the reset lever 27 (Fig.3) until it can be connected to the control levers 24 (Fig.3), and at this point, the reset lever will remain stable in its open position.

After these operations have been performed, the shutoff valve will be ready for service and the downstream valve (14) can be slowly reopened. When restoring normal operating conditions, the shutoff valve must always be reset whenever the valve is equipped with the minimum downstream pressure intervention function.

Trouble-Shooting

Malfunction

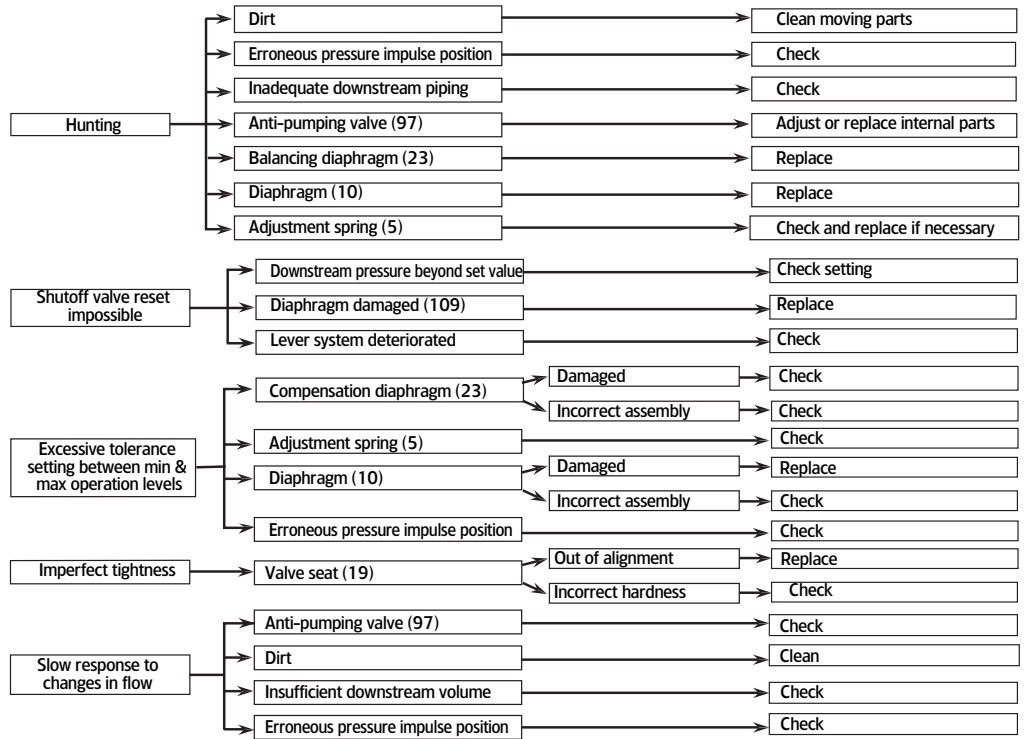

Pressure Beyond Regulator Setting

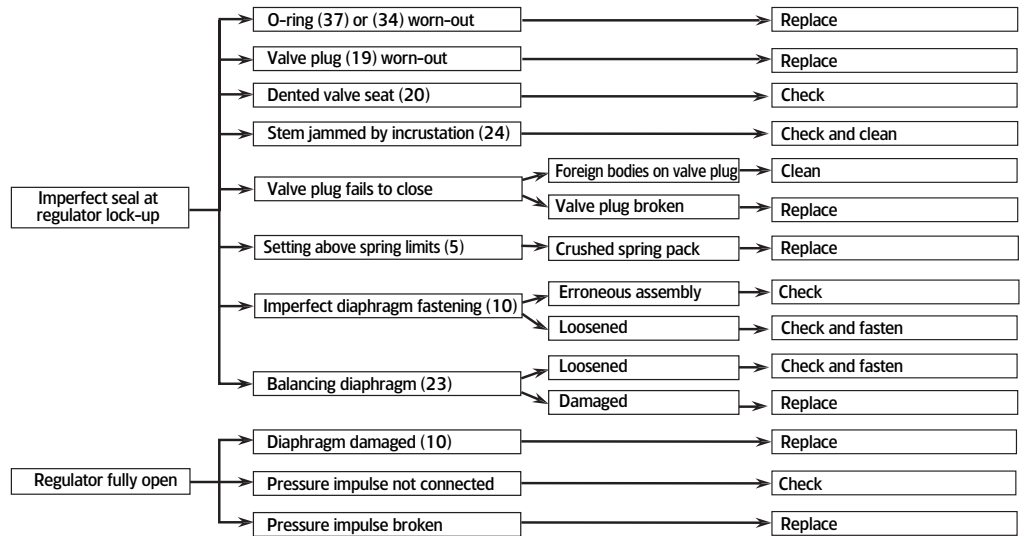

No Flow

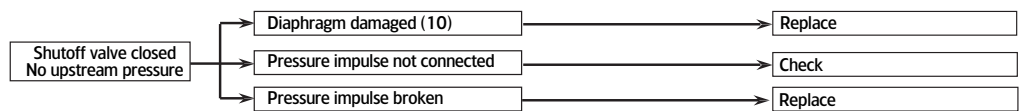

Low Downstream Pressure and Flow

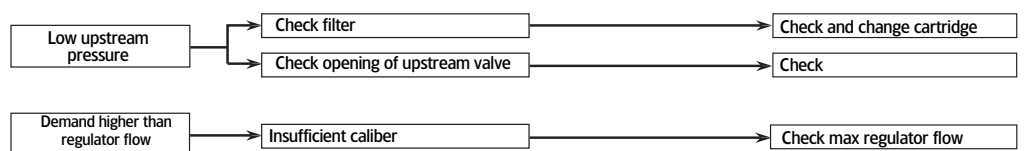

Parts List

Spare Parts KIT - RB4000		Description
Part No.		
39926101		Spare Parts Kit RB4010 2" Body
39926201		Spare Parts Kit RB4020 2" Body
39926301		Spare Parts Kit RB4030 2" Body
39927200		Spare Parts Kit RB4020 3" Body
39927300		Spare Parts Kit RB4030 3" Body
39927400		Spare Parts Kit RB4040 3" Body
39927120		Spare Parts Kit List RB4011- 4012 3" Body
39927310		Spare Parts Kit List RB4031- 4032 3" Body
39927410		Spare Parts Kit List RB4041- 4042 3" Body

The following table describes the contents of each of the RB4000 spare parts kits - Listed Below

► Part #39926101
Spare Parts Kit List for RB4010 (2" Body)

Item #	Part No.	Quantity	Description
10	20550290	1	Diaphragm RB4010 (2" Body) (REV.0)
19	20600260	1	Valve Plug ShA 55 RB4010 DN (2" Body) (REV.C)
23	20556290	1	Balancing Diaphragm RB4000 (2" Body) (II Series) (REV.0)
31	45000108	1	O-Ring or 108
32	45004312	1	O-Ring or 4312
33	45004325	2	O-Ring or 4325
34	45003231	1	O-Ring or 3231
35	45003262	1	O-Ring or 3262
36	45000112	1	O-Ring or 112
37	45003056	1	O-Ring or 3056
38	45003087	1	O-Ring or 3087
39	20030715	1	O-Ring "12" ShA 65 (ST.3007) (REV.A)
40	20080170	1	Nylon Busing D.12 (REV.0)
48	20080270	1	Nylon Bushing D.14 (REV.0)

► Part #39926201
Spare Parts Kit List for RB4020 (2" Body)

Item #	Part No.	Quantity	Description
10	20552390	1	Diaphragm RB4020 (2" Body) (REV.0)
19	20604260	1	Valve Plug ShA 75 RB4020 (2" Body) (REV.C)
23	20556290	1	Balancing Diaphragm RB4000 (2" Body) (II Series) (REV.0)
31	45000108	1	O-Ring or 108
32	45004312	1	O-Ring or 4312
33	45004325	2	O-Ring or 4325
34	45003231	1	O-Ring or 3231
35	45003262	1	O-Ring or 3262
36	45000112	1	O-Ring or 112
37	45003056	1	O-Ring or 3056
38	45003087	1	O-Ring or 3087
39	20030715	1	O-Ring "12" ShA 65 (ST.3007) (REV.A)
40	20080170	1	Nylon Busing D.12 (REV.0)
48	20080270	1	Nylon Bushing D.14 (REV.0)

Parts List - Continued

Item #	Part No.	Quantity	Description
10	20552990	1	Diaphragm RB4030 (2" Body) (REV.0)
19	20604260	1	Valve Plug ShA 55 RB4020 (2" Body) (REV.C)
23	20556290	1	Balancing Diaphragm RB4000 (2" Body) (II Series) (REV.0)
31	45000108	1	O-Ring or 108
32	45004312	1	O-Ring or 4312
33	45004325	2	O-Ring or 4325
34	45003231	1	O-Ring or 3231
35	45003262	1	O-Ring or 3262
36	45000112	1	O-Ring or 112
37	45003056	1	O-Ring or 3056
38	45003087	1	O-Ring or 3087
39	20030715	1	O-Ring "12" ShA 65 (ST.3007) (REV.A)
40	20080170	1	Nylon Busing D.12 (REV.0)
48	20080270	1	Nylon Bushing D.14 (REV.0)

Item #	Part No.	Quantity	Description
10	20552190	1	Diaphragm RB4020 (3" Body) (REV.0)
19	20601100	1	Valve Plug ShA 75 RB4020 DN (3" Body) (REV.0)
23	20555390	1	Balancing Diaphragm RB4000 (3" Body) (REV.0)
31	45000108	1	O-Ring or 108
32	45004450	1	O-Ring or 4450
33	45004475	2	O-Ring or 4475
34	45004362	1	O-Ring or 4362
35	45004387	1	O-Ring or 4387
36	45000115	1	O-Ring or 115
37	45000121	1	O-Ring or 121
38	45000132	1	O-Ring or 132
39	20030815	1	O-Ring "14" ShA 65 (ST.3008) (REV.A)
40	20080270	1	Nylon Busing D.14 (REV.0)
48	20080370	1	Nylon Bushing D.18 (REV.0)

Item #	Part No.	Quantity	Description
10	20552390	1	Diaphragm RB4020 (2" Body) (REV.0)
19	20601100	1	Valve Plug ShA 75 RB4020 (3" Body) (REV.0)
23	20555390	1	Balancing Diaphragm RB4000 (3" Body) (REV.0)
31	45000108	1	O-Ring or 108
32	45004450	1	O-Ring or 4450
33	45004475	2	O-Ring or 4475
34	45004362	1	O-Ring or 4362
35	45004387	1	O-Ring or 4387
36	45000115	1	O-Ring or 115
37	45000121	1	O-Ring or 121
38	45000132	1	O-Ring or 132
39	20030815	1	O-Ring "14" ShA 65 (ST.3008) (REV.A)
40	20080270	1	Nylon Busing D.14 (REV.0)
48	20080370	1	Nylon Bushing D.18 (REV.0)

► Part #39926301
Spare Parts Kit List for RB4030 (2" Body)

► Part #39927200
Spare Parts Kit List for RB4020 (3" Body)

► Part #39927300
Spare Parts Kit List for RB4030 (3" Body)

Parts List - Continued

► Part #39927400
Spare Parts Kit List for RB4040 (3" Body)

Item #	Part No.	Quantity	Description
10	20552990	1	Diaphragm RB4030 (2" Body) (REV.0)
19	20604260	1	Valve Plug ShA 55 RB4020 (2" Body) (REV.C)
23	20556290	1	Balancing Diaphragm RB4000 (2" Body) (II Series) (REV.0)
31	45000108	1	O-Ring or 108
32	45004312	1	O-Ring or 4312
33	45004325	2	O-Ring or 4325
34	45003231	1	O-Ring or 3231
35	45003262	1	O-Ring or 3262
36	45000112	1	O-Ring or 112
37	45003056	1	O-Ring or 3056
38	45003087	1	O-Ring or 3087
39	20030715	1	O-Ring "12" ShA 65 (ST.3007) (REV.A)
40	20080170	1	Nylon Busing D.12 (REV.0)
48	20080270	1	Nylon Busing D.14 (REV.0)

► Part #9927120
Spare Parts Kit List for RB4011 - 4012
(3" Body)

Item #	Part No.	Quantity	Description
10	20555290	1	Diaphragm RB4010 (3" Body) (REV.A)
19	20600100	1	Valve Plug ShA 55 RB4010 (3" Body) (REV.0)
23	20555390	1	Balancing Diaphragm RB4000 (3" Body) (REV.0)
31	45000115	2	O-Ring or 115
32	45004450	1	O-Ring or 4450
33	45004475	2	O-Ring or 4475
34	45004362	2	O-Ring or 4362
35	45004387	1	O-Ring or 4387
37	45000121	1	O-Ring or 121
38	45000132	1	O-Ring or 132
39	20030815	1	O-Ring "14" ShA 65 (ST.3008) (REV.A)
40	20080270	1	Nylon Busing D.14 (REV.0)
48	20080370	3	Nylon Busing D.18 (REV.0)
54	20500270	1	Cap Gasket for VDB 8600 (REV.0)
56	48000804	1	Elastic Pin 3 x 20 UNI 6873
57	20600200	1	Valve Plug RB4011 (3" Body) (REV.B)
60	45000128	2	O-Ring or 128
65	45003037	2	O-Ring or 3037
109	20558290	1	Diaphragm VDB 8600 L.P. (REV.0)
117	45004437	1	O-Ring or 4437

► Part #39927310
Spare Parts Kit List for RB4031 - 4032
(3" Body)

Item #	Part No.	Quantity	Description
10	20552390	1	Diaphragm RB4020 (2" Body) (REV.0)
19	20601100	1	Valve Plug ShA 75 RB4020 (3" Body) (REV.0)
23	20555390	1	Balancing Diaphragm RB4000 (3" Body) (REV.0)
31	45000108	1	O-Ring or 108
32	45004450	1	O-Ring or 4450
33	45004475	2	O-Ring or 4475
34	45004362	2	O-Ring or 4362
35	45004387	1	O-Ring or 4387
36	45000115	1	O-Ring or 115
37	45000121	1	O-Ring or 121
38	45000132	1	O-Ring or 132
39	20030815	1	O-Ring "14" ShA 65 (ST.3008) (REV.A)
40	20080270	1	Nylon Busing D.14 (REV.0)
48	20080370	1	Nylon Busing D.18 (REV.0)
67	20551690	1	Shut-Off Valve Diaphragm RB4021 (REV.0)
72	20600200	1	Valve Plug RB4011 (3" Body) (REV.B)
75	45000112	1	O-Ring or 112
76	45003237	1	O-Ring or 3237
77	45003087	1	O-Ring or 3087
78	20030415	1	O-Ring "10" ShA 65 (ST.3001) (REV.B)
85	48000804	1	Elastic Pin 3 x 20 UNI 6873
86	45004437	1	O-Ring or 4437

Parts List - Continued

Item #	Part No.	Quantity	Description
10	20552990	1	Diaphragm RB4030 (REV.0)
19	20601100	1	Valve Plug ShA 75 RB4020 (3" Body) (REV.0)
23	20555390	1	Balancing Diaphragm RB4000 (3" Body) (REV.0)
31	45000108	1	O-Ring or 108
32	45004450	1	O-Ring or 4450
33	45004475	2	O-Ring or 4475
34	45004362	1	O-Ring or 4362
35	45004387	1	O-Ring or 4387
36	45000115	1	O-Ring or 115
37	45000121	1	O-Ring or 121
38	45000132	1	O-Ring or 132
39	20030815	1	O-Ring "14" ShA 65 (ST.3008) (REV.A)
40	20080270	1	Nylon Busing D.14 (REV.0)
48	20080370	1	Nylon Busing D.18 (REV.0)
67	20555090	1	Shut-Off Valve Diaphragm RB4031 (REV.0)
72	20600200	1	Valve Plug RB4011 (3" Body) (REV.B)
75	45000112	1	O-Ring or 112
76	45003237	1	O-Ring or 3237
77	45003087	1	O-Ring or 3087
78	20030415	1	O-Ring "10" ShA 65 (ST.3001) (REV.B)
85	48000804	1	Elastic Pin 3 x 20 UNI 6873
86	45004437	1	O-Ring or 4437

Special Tools	Part #	Description
	39926000	Orifice Wrench 2" Valve Body
	39927000	Orifice Wrench 3" Valve Body
	799056	Spring Adjustment Wrench

Adjustment Springs

Part Number	Spring Color
20568085	Orange/Silver
20568086	Brown/Silver
20568087	Dark Green/Silver
20568088	Light Green/Silver
20568089	Light Blue/Silver
20568090	Black/Silver
20568081	Purple/Silver
20568082	Yellow
20568083	Blue/Silver
20568183	Blue
20568182	Silver
20568181	Purple
20568186	Yellow/Silver
20568184	Red/Silver
20568185	White/Silver
20569590	Orange
20569591	Brown
20569592	Dark Green
20569593	Light Green
20569594	Black
20569690	Red
20569691	Light blue
20569585	White
20569586	Pink

► Part #39927410
Spare Parts Kit List for RB4041 - 4042
(3" Body)

RB4000 Reference Schematic

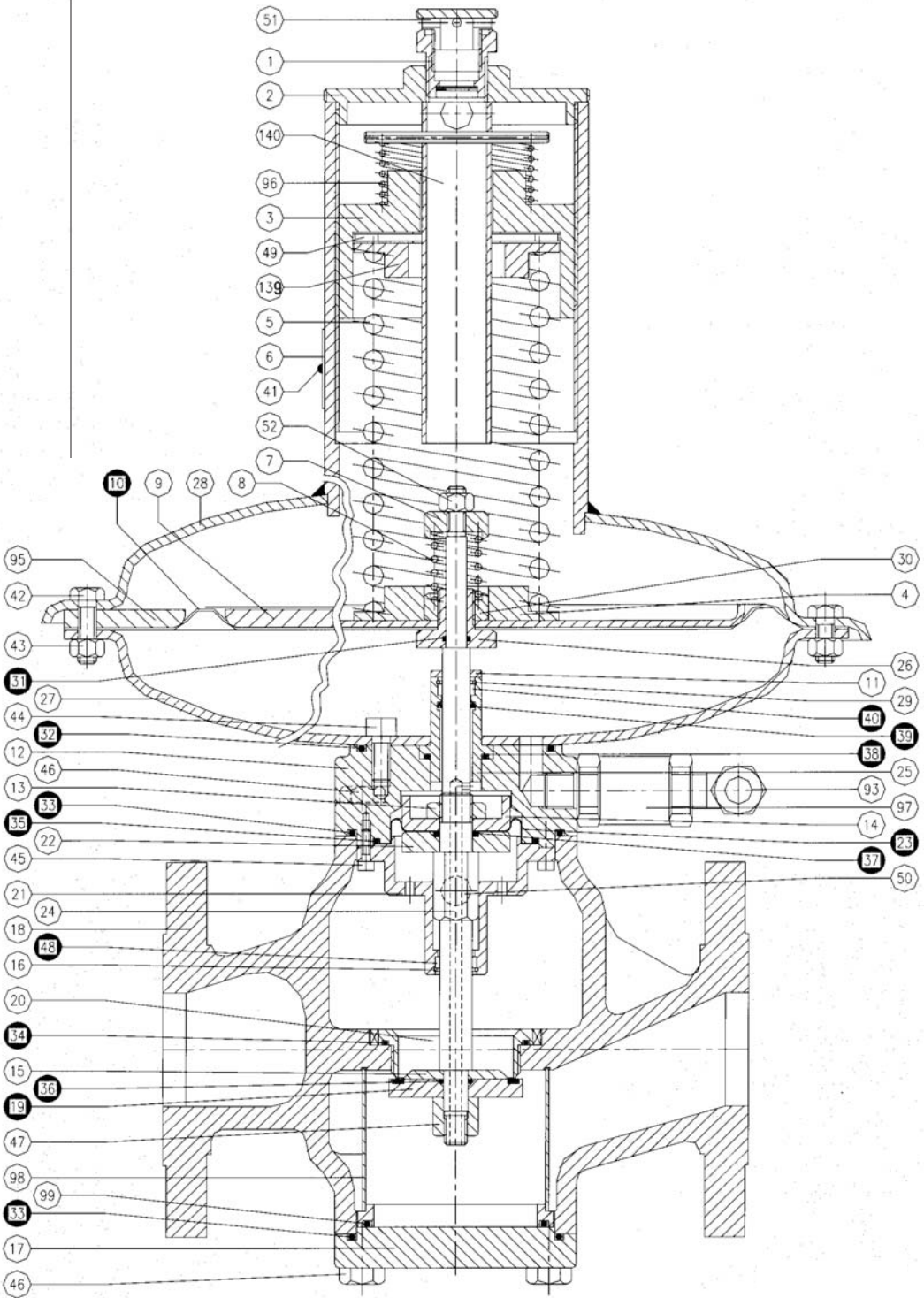

This Page Left Intentionally Blank

Limited Warranty

Actaris U.S. Gas, Inc., 970 Highway 127 North, Owenton, Kentucky 40359-9302, warrants this gas product against defects in materials and workmanship for the earlier of one (1) year from the date the product is shipped by Actaris or a period of one year from the date the product is installed by Actaris at the original purchaser's site. During such one-year period, provided that the original purchaser continues to own the product, Actaris will, at its sole option, repair any defects, replace the product or repay the purchase price.

- This warranty will be void if the purchaser fails to observe the procedures for installation, operation or service of the product as set forth in the Operating Manual and Specifications for the product or if the defect is caused by tampering, physical abuse or misuse of the product.

► Ordering Information

Specify:

1. Inlet and Outlet Connection Size and Type
2. Model Number
3. Outlet pressure desired
4. Inlet pressure range
5. Type of gas and maximum capacity required
6. Vent size
7. Special requirements such as tagging, seal wire, etc.

- **ACTARIS SPECIFICALLY DISCLAIMS ALL IMPLIED WARRANTIES INCLUDING THOSE OF MERCHANTABILITY OR OF FITNESS FOR A PARTICULAR PURPOSE. UNDER NO CIRCUMSTANCES WILL ACTARIS BE LIABLE FOR INCIDENTAL OR CONSEQUENTIAL DAMAGES OF ANY KIND WHATSOEVER.**

- Actaris' liability for any claim of any kind, including negligence and breach of warranty for the sale and use of any product covered by or furnished, shall in no case exceed the price allocable to the product or part thereof which gives rise to the claim.

- In the event of a malfunction of the product, consult your Actaris Service Representative or Actaris U.S. Gas, Inc., 970 Highway 127 North, Owenton, Kentucky 40359-9302.

See Actaris Terms and Conditions of Sale for the full and complete terms of the Limited Warranty.

► Reference Information:

- Product Overview, JOB

Actaris U.S. Gas, Inc.

970 Highway 127 North

Owenton, Kentucky 40359-9302, USA

For more information, www.actarisusgas.com

tel +1 800 490 0657

+1 502 484 5747

fax +1 502 484 6223