



RB1700 Series Regulator

Medium Duty Commercial & Industrial Regulator

- ▶ Accurate regulation
- ▶ Fast response
- ▶ Easy maintenance
- ▶ Compact size
- ▶ Wide range of outlet pressure
- ▶ Horizontal or Vertical mounting

Features

- Interchangeable adjustment spring
- Balanced valve design
- Downstream control



Applications

The RB1700 regulator is designed for commercial applications: industrial boilers and furnaces, appliance pressure regulation, secondary regulation of plant distribution piping, and all installations with continuous consumption and rapid flow rate variations, such as burners, industrial ovens, boilers, etc. Suitable for installing in cabinets, as a space saving regulator.

Description

The RB1700 is a direct-acting, spring-loaded regulator. The balanced valve design ensures a constant outlet pressure when the upstream pressure varies. This eliminates the need for orifice size changes arising from the different inlet pressure ranges.

Principle of Operation (See Operating Schematic right)

The RB1700 employs a direct-acting spring-loaded design that allows for extremely fast response as well as reliable closure during no-load conditions.

Increasing Load Condition:

As downstream demand increases, the downstream pressure begins to fall, which, in turn causes the sensing line pressure and the pressure under the main diaphragm to decrease. When the pressure under the main diaphragm drops, the spring force is able to move the diaphragm downward and, thus, the main valve further open to meet the increased demand.

Decreasing Load Condition:

As the downstream load is decreased, the pressure begins to rise in the sensing line and under the main diaphragm. The pressure under

the main diaphragm overcomes the spring force and moves the diaphragm upward. This allows the valve to move closer to the orifice face and decrease the flow through the valve until it matches the downstream demand.

No Load (lock-up) Condition:

As the downstream load is shut-off, the pressure begins to rise in the sensing line and under the main diaphragm. The pressure under the main diaphragm overcomes the spring force and moves the diaphragm upward. The pressure rises enough to push the rubber valve seat against the stainless steel orifice, forming a positive seal during no-load conditions.

- Inlet Pressure
- Outlet Pressure

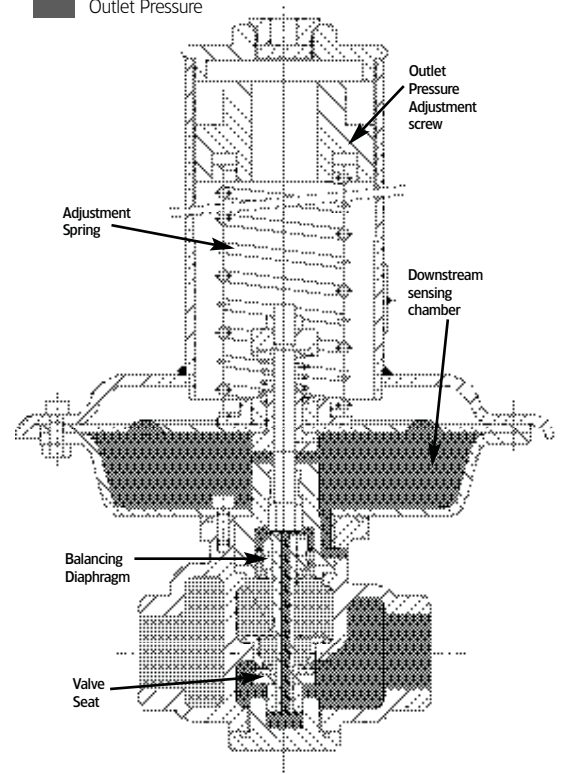

Correction factors for non-natural gas applications:

The RB1700 may be used to control gases other than natural gas. To determine the capacity of the RB1700 for gases other than natural gas, it will be necessary to multiply the values within the capacity tables by a correction factor.

The table below lists the correction factors for some of the more common gases:

Gas Type	Specific Gravity	Correction Factor (CF)
Air	1.00	0.77
Butane	2.01	0.55
Carbon Dioxide (Dry)	1.52	0.63
Carbon Monoxide (Dry)	0.97	0.79
Natural gas	0.60	1.00
Nitrogen	0.97	0.79
Propane	1.53	0.63
Propane-air-mix	1.20	0.71

To calculate the correction factor for gases not listed on the table above, it will be necessary to know the specific gravity of the gas and use it in the formula listed below:

$$\text{Correction Factor (CF)} = \sqrt{\frac{SG_1}{SG_2}}$$

Where:

- SG₁ = Specific Gravity of the gas in which the capacity is published.
- SG₂ = Specific Gravity of the gas to be controlled.

Construction

Valve Body:	Ductile Iron
Orifice:	Stainless Steel
Valve Seat:	Brass with vulcanized Buna-N
Valve Stem:	Stainless Steel
Valve Stem Bushings:	Nylon
“O”-ring Seals:	Buna-N Nitrile Rubber
Diaphragm:	Buna-N and nylon reinforcing fabric
Adjustment screw:	Brass
Diaphragm Case:	Steel

Shipping Weight:

1 Regulator per box:	Weight per box: 35 lbs.
----------------------	-------------------------

Model Designations

R	X	X	1	7	X	X	Options
	B						Balanced Valve Design
		E					External Registration
					1		Low pressure (7" w.c. - 3.0 PSIG)
					2		Medium pressure (1.7 - 13.0 PSIG)
					3		High pressure (7.3 - 36.0 PSIG)
						0	No safety devices
						1-1/2"	1-1/2" body - Orifice size: 1-1/8"

Example: RBE1720 with 1-1/2" body is a 1700 series regulator with balanced valve, an External Control line, and 1-1/2" NPT Valve body connection.

Specifications

Spring Range Data	Model Number		
	RB1710 (14" diaphragm)	RB1720 (8" diaphragm)	RB1730 (8" diaphragm)
Yellow (p/n 20567075)	6.8-9.2" w.c.	---	---
Red (p/n 20567076)	8.4-12.8" w.c.	---	---
White (p/n 20567662)	10.9-21.2" w.c.	---	---
Purple (p/n 20567663)	0.3-1.4 PSIG	1.9-5.3 PSIG	---
Orange (p/n 20567664)	1.2-3.0 PSIG	2.9-8.7 PSIG	---
Brown (p/n 20567665)	---	4.4-9.4 PSIG	7.3-14.5 PSIG
Green (p/n 20567666)	---	5.8-13.0 PSIG	8.7-19.5 PSIG
Black (p/n 20567761)	---	---	11.6-21.7 PSIG
Grey (p/n 20567762)	---	---	16.0-36.0 PSIG

Maximum Inlet Pressure:	230 PSIG
Outlet Pressure Range:	6.8" w.c. - 36.0 PSIG
Temperature Range:	-20°F to + 140°F
Acceptable gases:	Natural gas, propane, butane, air, nitrogen or any non-corrosive gas
Mounting Position:	Horizontal or vertical
Pressure Registration:	External (control line required - 1/4" NPT)
Vent Connection:	1/4" NPT
Valve Body sizes:	1-1/2" NPT
Orifice sizes:	1-1/8"
Other available options:	Seal wire to indicate unapproved tampering

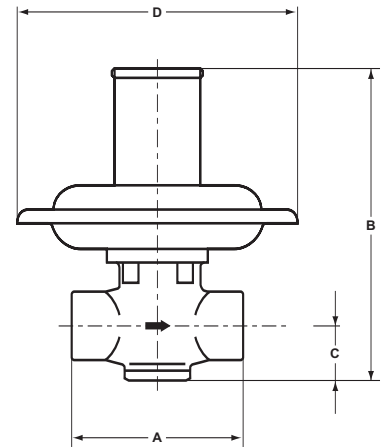

► RB1700 Dimensions (in inches)

Dimensions (inches)	Model	
	1710	1720 1730
A	5.9	5.9
B	15.7	13.8
C	2.4	2.4
D	14.0	8.0
Weight (lbs.)	33	28

► Valve Body Size

Inlet	Outlet	Orifice Diameter (inches)	Wide-Open Flow Coefficient (K-Factor)
1-1/2"	1-1/2"	1-1/8"	1120

Wide-Open Flow Calculations

For wide-open orifice flow calculations use the following equations:

$$\text{For } P_1/P_2 < 1.89 \text{ use: } Q = K \sqrt{P_2 (P_1 - P_2)} \quad \text{For } P_1/P_2 > 1.89 \text{ use: } Q = \frac{KP_1}{2}$$

Where: P_1 = absolute inlet pressure (psia) P_2 = absolute outlet pressure (psia)
 Q = flow rate (scfh) K = orifice coefficient (scfh/psi)

RB1700 Series Medium Duty Commercial & Industrial Regulator

Capacity Table

(capacities in SCFH of 0.6 S.G. gas; Base condition of 14.7 psia and 60°F)

Inlet Pressure (PSIG)	Model RB1710				Model RB1720			
	Outlet Pressure							
	7" w.c.	11" w.c.	14" w.c.	1 PSIG	2 PSIG	5 PSIG	10 PSIG	
	1" w.c. Droop Yellow Spring Part #20567075	2" w.c. Red Spring Part #20567076	2" w.c. White Spring Part #20567662	0.1 PSIG Droop (0.2 PSIG Droop) Purple Spring Part #20567663	0.2 PSIG Droop (0.4 PSIG Droop) Orange Spring Part #20567664	0.5 PSIG Droop (1 PSIG Droop) Purple Spring Part #20567663	1 PSIG Droop (2 PSIG Droop) Green Spring Part #20567666	
8" w.c.	2300							
10" w.c.	2800							
12" w.c.	3000	3000						
14" w.c.	3700	3600						
16" w.c.	4300	4000	3900					
18" w.c.	5100	4400	4200					
24" w.c.	5600	4900	4600					
1	6000	5500	5300					
2	9000	9500	9200	7000 (9200)				
3	11500	12000	11500	10500 (12000)	5500 (8000)			
5	15000	16000	15300	13500 (15000)	10500 (13000)			
10	26000	24500	23600	18500 (22000)	15500 (18500)	13500 (19500)		
20	33000	31500	30500	29500 (31000)	27000 (34000)	24000 (32500)	22000 (29000)	
30	38100	38000	36900	34000 (38000)	31300 (35500)	33000 (38700)	30500 (39000)	
40	47000	46500	45000	41650 (46500)	38300 (43500)	36100 (47300)	36000 (46800)	
50	55200	55000	53000	49300 (55000)	45500 (51400)	42700 (56000)	42500 (55300)	
60	63800	63500	61500	56900 (63500)	52300 (59400)	49300 (64600)	49100 (63900)	
70	72300	72000	69500	64500 (72000)	59600 (67300)	55900 (73300)	55700 (72400)	
80	80800	80500	78500	72100 (80500)	66000 (75000)	62500 (82000)	62300 (81000)	
90	89400	89000	86300	79700 (89000)	73500 (83200)	69100 (90500)	68900 (89500)	
100	97900	97500	95000	87300 (97500)	80000 (91100)	75700 (99200)	75400 (98100)	
125	119200	118700	114000	106000 (118700)	98000 (111000)	92200 (120800)	91800 (119400)	
Lock-Up Pressure	8.2" w.c.	11.9" w.c.	14.7" w.c.	1.3 PSIG	2.2 PSIG	5.1 PSIG	10.3 PSIG	

7" w.c. - RB1700 Series Medium Duty Commercial & Industrial Regulator

RB1710 Regulator Performance

7" w.c. SET POINT

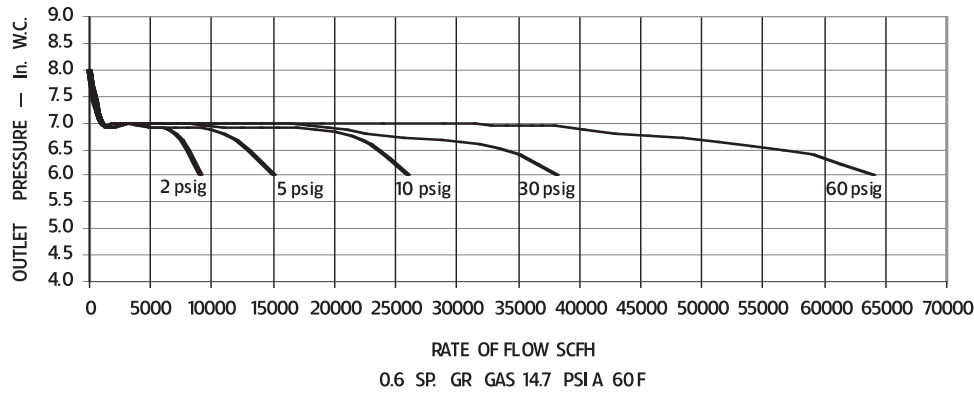

Typical Performance Curve

Manufacturer:	Actaris
Type and Model:	RB1710
Regulator:	Inlet Size 1-1/2" NPT
	Outlet Size 1-1/2" NPT
	Orifice Size 1-1/8"
	Spring P/N 20567075

2 PSIG - RB1700 Series Medium Duty Commercial & Industrial Regulator

RB1720 Regulator Performance

2 PSIG SET POINT

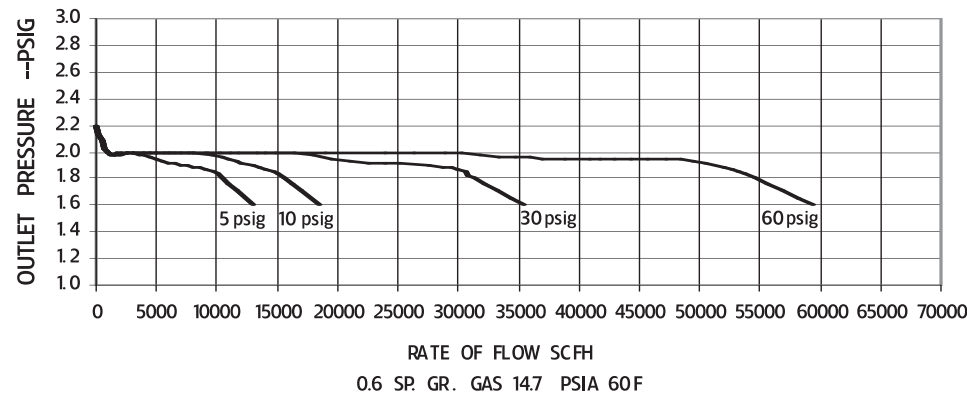

Typical Performance Curve

Manufacturer:	Actaris
Type and Model:	RB1720
Regulator:	Inlet Size 1-1/2" NPT
	Outlet Size 1-1/2" NPT
	Orifice Size 1-1/8"
	Spring P/N 20567664

Installation

Before installing the pressure regulator in the piping the following must be checked:

- ▶ The pressure regulator must be capable of being installed without undue stress to the valve body.
- ▶ The upstream piping must be cleaned from all impurities (sand, welding slag, etc.)
- ▶ The pressure regulator must not be visibly damaged.
- ▶ The inlet and outlet chambers of the pressure regulator must be perfectly clean.

After these checks have been made, the unit can be installed in the piping, making sure that the direction of gas flow corresponds to the arrow on the pressure regulator's body.

NOTE: It is recommended the valve body installed in horizontal alignment.

The following are also recommended:

- ▶ A electrically insulating joint upstream and downstream, if the incoming and outgoing piping is made with ferrous material.
- ▶ An ON/OFF valve upstream and downstream of the pressure regulator.
- ▶ A manometer or pressure gauge upstream and downstream from the pressure regulator.
- ▶ An upstream filter.
- ▶ A relief valve downstream for start-up and changes in pressure setting
- ▶ A relief valve for accidental over-pressure (example: the exposure of the downstream piping to direct sunlight at zero flow).
- ▶ Allow enough clearance around the regulator to perform maintenance operations
- ▶ In the case of an ON/OFF gas load, the downstream volume must be greater than 1 ft³ per 1000 ft³/hr. of flow rate.

All variations in diameter downstream must be performed progressively in order to prevent negative turbulence.

Avoid locating the control line piping:

- ▶ Near sources of heat
- ▶ Direct sun light.

The pressure regulator's control line must be connected to the downstream pipe. These connections must be inserted in a straight section of the downstream piping as indicated in the installation diagram (Figure 4).

For this purpose, we recommend welding the control line connections on the upper part of the piping in order to prevent impurities and condensation from collecting and obstructing the passage of the gas. It is also important to make sure that the control line piping slopes slightly downwards to the pipe. For adequate operation, the gas velocity at the control line position in the pipe, must not exceed those given below.

Low pressure
<2.9 psig: 50-65 ft/s

Med/high pressure
>2.9 psig: 65-130 ft/s

Start-Up Procedure

After the pressure regulator has been installed, make sure that:

- ▶ The on/off valve upstream (1) and downstream (14) and the bleeder valve (13) are all closed

After these checks have been made, proceed as follows:

- ▶ Partially open the upstream on/off valve (1) slowly just enough to make sure that a very small amount of gas passes;
- ▶ Check that the pressure rises slowly on the gauges (4) and (12); the downstream pressure should stabilize around the pre-set value or a value slightly higher (if the pressure continues to rise, discontinue the starting procedure by closing the upstream on/off valve (1) and consult the trouble-shooting diagram to identify the cause of the malfunction);
- ▶ After the upstream pressure valve has stabilized, open the on/off valve (1) completely;
- ▶ Then slowly open the downstream on/off valve (14) until the piping is completely filled.

The pressure regulator is now ready for operation.

Outlet Pressure Adjustment

The pressure regulator is usually delivered adjusted to the specifications indicated in the order.

Whenever the set pressure must be modified, this value must be set within the setting range of the spring installed.

After first checking the suitability of the spring installed to achieve the desired setting value, proceed as follows:

- ▶ **To increase the value of the set pressure:**
Rotate the spring adjustment ferrule nut clockwise using the adjustment wrench until the desired value is reached. **(Note: Model RB1710 required a 1" socket for adjustment; Models RB1720 and RB1730 required adjustment tool Part #799056)**
- ▶ **To decrease the value of the set pressure:**
Proceed as above, rotating the spring adjustment ferrule counter-clockwise.

Figure #4

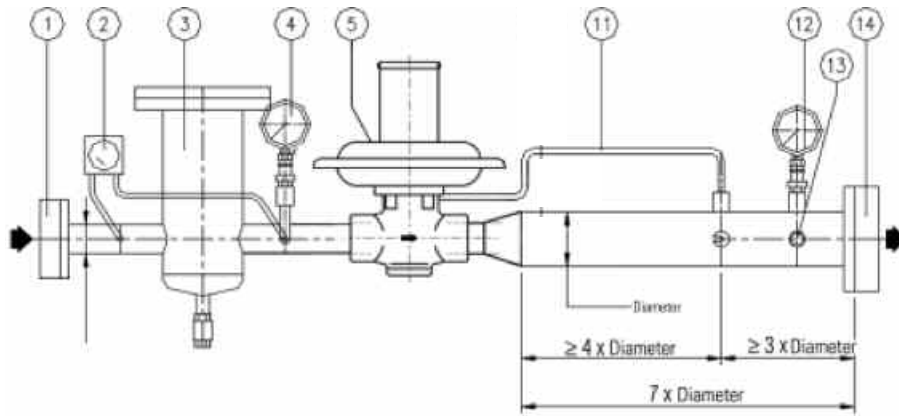

► Key

No.	Description
1.	Upstream valve
2.	Differential pressure gauge
3.	Strainer/Filter
4.	Upstream pressure gauge
5.	Regulator
11.	Regulator control line
12.	Downstream pressure gauge
13.	Discharge vent pipe
14.	Downstream valve

Vent Lines for Regulators

When constructing vent lines to be attached to regulators installed indoors, a few basic rules must be followed:

1. Never use pipe sizes smaller than the vent size itself; anything smaller will restrict the flow of gas. If a long run must be used, it is advisable to increase the pipe one size every ten feet in order to keep the flow restriction as low as possible.
2. Keep the length of vent line as short as possible to minimize the restriction as well as reduce the tendency for the vent piping to cause pulsation of the regulator.
3. Support the vent pipe so there is no strain on the regulator diaphragm case.
4. Always point the end of the vent pipe located outside the building in the downward position to reduce the possibility of rain, snow, sleet etc. from entering the pipe. A bug screen should be installed in the end of the pipe.
5. The terminus of the vent line must not be located near windows, fans, etc. See the installation instructions furnished with the regulator.
6. All applicable codes and regulations must be adhered to.
7. Vent pipe may cause regulator pulsation. If this situation occurs, please consult your regulator representative or the factory.
8. It is strongly recommended that a separate vent line be run for each regulator; a header with other devices installed in it can cause regulator malfunction.
9. If approved by the authority having jurisdiction, the vent lines may be manifolded in accordance with accepted engineering practices to minimize backpressure in the event of diaphragm failure.

RB1700

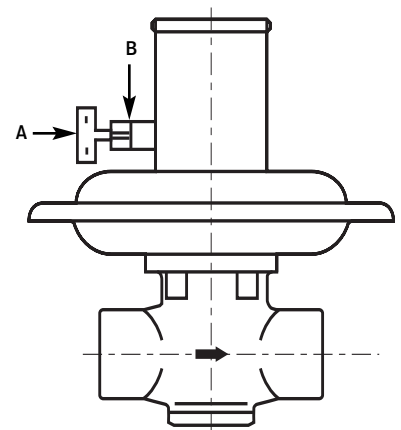

NOTE:

To install 1/4" vent pipe into the upper casing of the pressure regulator, the breather cap "A" will need to be removed. Do not remove the diaphragm breather assembly "B". The vent pipe is necessary in case of diaphragm failure.

Trouble-Shooting Guide

Malfunctions	Possible Problem	Solution
Hunting or pulsating	Dirt	Clean moving parts
	Erroneus pressure sensing location	Check
	Undersized downstream piping	Check
	Spring seal cap not in place	Install spring seal cap
	Balancing diaphragm	Replace
	Diaphragm	Replace
	Adjustment spring	Check and replace if necessary
Excessive tolerance setting between min & max operation levels	Compensation diaphragm	Damaged → Check Incorrect assembly → Check
	Adjustment spring	Check
	Diaphragm	Damaged → Replace Incorrect assembly → Check
	Erroneus pressure sensing location	Check
Reg. won't "lock-up"	Valve seat	Damaged → Replace Incorrect hardness → Check
Slow response to changes in flow	Anti-pumping valve	Check
	Dirt on valve stem	Clean
	Insufficient downstream volume	Check
	Erroneus pressure sensing location	Check
Imperfect seal at regulator "lock-up"	O-ring in valve seat worn-out	Replace
	Valve seat worn-out	Replace
	Dented valve seat	Check
	Stem jammed by debris	Check and clean
	Valve plug fails to close	Foreign bodies on valve seat → Clean Valve seat broken → Replace
	Setting above spring limits	Crushed spring pack → Replace
	Imperfect diaphragm assembly	Erroneous assembly → Check Loosened → Check and fasten
	Balancing diaphragm	Loosened → Check and fasten Damaged → Replace
Regulator fully open	Diaphragm damaged	Replace
	Sensing line not connected	Check
	Sensing line broken	Replace
Low upstream pressure	Check filter	Check and change cartridge
	Check opening of upstream valve	Check
Low downstream pressure	Demand in excess of Max. flow rate	Check max regulator flow

Parts List

Spare Parts KIT - RB1710	
Part No.	Description
20554590	Balancing Diaphragm RBE 1700 DN 1-1/2" (REV.O)
20554790	Diaphragm RBE 4010 DN 25 (REV.O)
20603360	Valve Plug ShA55 RBE 1710 DN 1-1/2" (REVC)
45000108	O-Ring or 108
45000114	O-Ring or 114
45003150	O-Ring or 3150
45003181	O-Ring or 3181
Spare Parts KIT- RB1720	
Part No.	Description
20552490	Diaphragm RBE 4020 DN 25 (REVA)
20554590	Balancing Diaphragm RBE1700 DN 1-1/2" (REV.O)
20604360	Valve Plug ShA75 RBE1720 DN 1-1/2" (REVB)
45000108	O-Ring or 108
45000114	O-Ring or 114
45003150	O-Ring or 3150
45003181	O-Ring or 3181
Spare Parts KIT - RB1730	
Part No.	Description
20554590	Balancing Diaphragm RBE1700 DN 1-1/2" (REV.O)
20556490	Valve Plug ShA75 RBE1720 DN 1-1/2" (REVB)
4500108	O-Ring or 108
45000114	O-Ring or 114
45003150	O-Ring or 3150
45003181	O-Ring or 3181

This page left Intentionally blank

This page left Intentionally blank

Limited Warranty

Actaris U.S. Gas, Inc., 970 Highway 127 North, Owenton, Kentucky 40359-9302, warrants this gas product against defects in materials and workmanship for the earlier of one (1) year from the date the product is shipped by Actaris or a period of one year from the date the product is installed by Actaris at the original purchaser's site. During such one-year period, provided that the original purchaser continues to own the product, Actaris will, at its sole option, repair any defects, replace the product or repay the purchase price.

- This warranty will be void if the purchaser fails to observe the procedures for installation, operation or service of the product as set forth in the Operating Manual and Specifications for the product or if the defect is caused by tampering, physical abuse or misuse of the product.

► Ordering Information

Specify:

1. Inlet and Outlet Connection Size and Type
2. Model Number
3. Outlet pressure desired
4. Inlet pressure range
5. Type of gas and maximum capacity required
6. Special requirements such as tagging, seal wire, etc.

• ACTARIS SPECIFICALLY DISCLAIMS ALL IMPLIED WARRANTIES INCLUDING THOSE OF MERCHANTABILITY OR OF FITNESS FOR A PARTICULAR PURPOSE. UNDER NO CIRCUMSTANCES WILL ACTARIS BE LIABLE FOR INCIDENTAL OR CONSEQUENTIAL DAMAGES OF ANY KIND WHATSOEVER.

- Actaris' liability for any claim of any kind, including negligence and breach of warranty for the sale and use of any product covered by or furnished, shall in no case exceed the price allocable to the product or part thereof which gives rise to the claim.

- In the event of a malfunction of the product, consult your Actaris Service Representative or Actaris U.S. Gas, Inc. 970 Highway 127 North, Owenton, Kentucky 40359-9302.

See Actaris Terms and Conditions of Sale for the full and complete terms of the limited warranty.

► Reference Information

- Product Overview, JOB

Actaris U.S. Gas, Inc.

970 Highway 127 North

Owenton, Kentucky 40359-9302, USA

For more information, www.actarissusgas.com

tel +1 800 490 0657

+1 502 484 5747

fax +1 502 484 6223