

Features

- Modular design
- Built in pressure taps (RM)
- Lubrication free bearing surfaces
- 4 chamber design
- AMR compatible
- Top entry adjustment
- Tamper resistant design
- Common measurement module
- 5/16" 4 nut adjustment mechanism

Benefits

- Compact Size
- Better overall aesthetics
- Fewer potential leak points
- Easy handling
- Simplified service/repair
- Flexible piping configurations
- Long life
- Maintenance free operation
- Cost effective temperature compensation

Application

The METRIS gas meter is designed to offer modular flexibility and measurement accuracy for residential to light commercial applications.

- METRIS 250: Standard Retrofit Application
- METRIS RM: Total Measurement Application
- METRIS MB: Sub-Metering Application

Designed to Increase Your Customer's Satisfaction and Reduce Your Total Costs

The METRIS meter is uniquely constructed to give utilities the edge they need in an increasingly complex and competitive marketplace. The METRIS offers three versions that provide greater flexibility for your metering needs. The unique modular

design of the METRIS offers the advantage of complete customization to fit individual installation needs. In addition, due to inventory and manufacturing enhancements provided by modularity, this invaluable flexibility can also be delivered with unparalleled speed and scheduling dependability.

Modular Versatility



Regulator/Manifold

- B42R pressure regulator
- Pressure taps - regulator inlet, regulator outlet, & meter outlet
- Cast iron manifold for installation strength
- Field replaceable regulator diaphragm case

AMR Compatibility

- Slant face Sprague Meter mounting design
- Compatible with all AMR manufacturers

Measurement Module

- Common between all 3 versions
- Seamless single convolution diaphragm
- Lubrication free bearing surfaces
- Direct diaphragm support
- Remanufacture meters in record time

Die Cast Housing

- Lifetime warranty*
- Bottom case common between all 3 versions

* See our CERTIFICATE OF LIMITED WARRANTY, Supplement A1T-1, for the full terms applicable to the METRIS Meter.



METRIS 250:

Standard Retrofit Application

- 20% lighter than competitive meters
- Square base for handling stability
- Common measurement module



METRIS RM:

Total Measurement Application

- Integral full performance regulator and meter bar
- Cost saving design (5-15% reduction)
- Remove meter from service independent of regulator
- Three pressure taps for field maintenance



METRIS MB:

Sub-Metering Application

- Back inlet and outlet connections
- Tight meter sets
- 3/4 or 1" connections

Compact Size

While the METRIS is more compact than traditional meters, it was also designed to meet customer expectations to be returned to the field after meter sampling or meter changeouts. The METRIS is also rated at a full 250 CFH. The square base of the METRIS and its 33% reduction in weight provide for stability and reduced shipping costs.

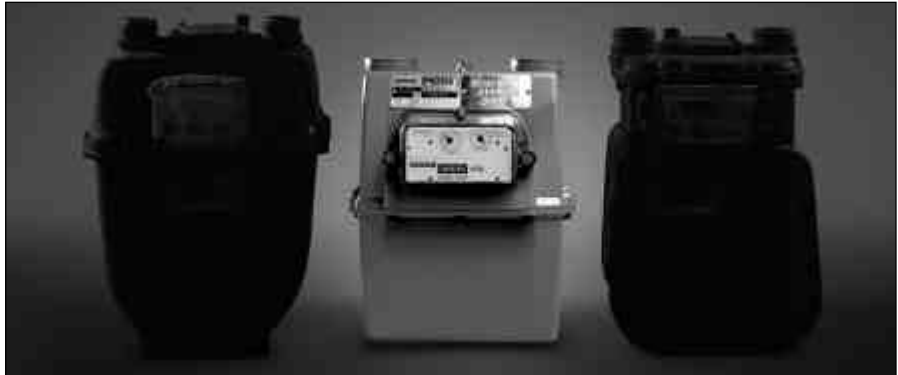

Clean, Simple installation

Current gas meters cannot compare to the clean, simple installation and aesthetics of the METRIS RM. The RM solution reduces the number of connections, the amount of piping and the need to manipulate awkward connection points. As a result, the utility's time and work force investment is reduced.

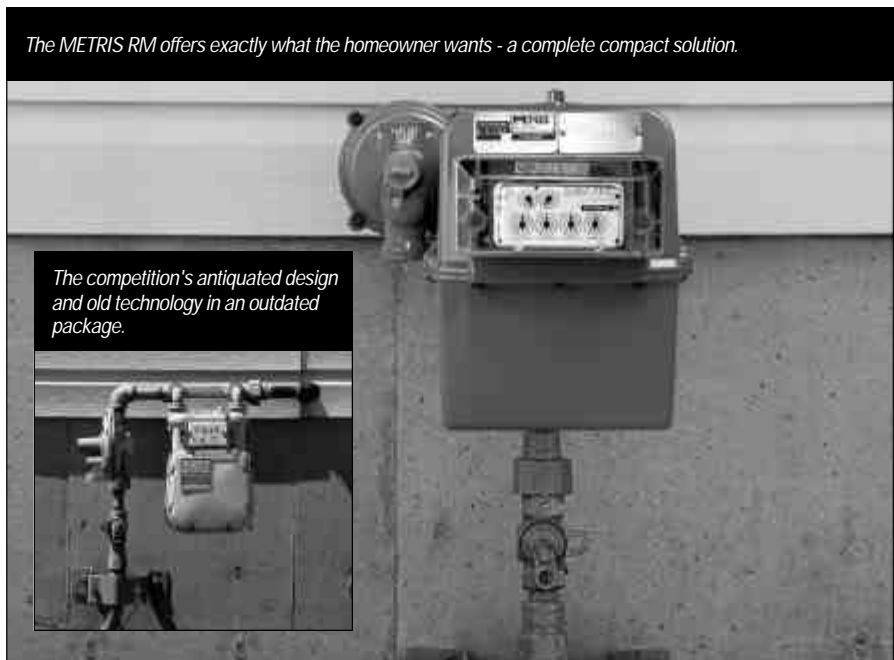

The METRIS RM offers exactly what the homeowner wants - a complete compact solution.

The competition's antiquated design and old technology in an outdated package.

Correction factors for non-natural gas applications:

The METRIS may be used to control materials other than natural gas. To determine the capacity of the METRIS for gases other than natural gas, it will be necessary to multiply the values within the capacity tables by a correction factor. The table below lists the correction factors for some of the more common gases:

Gas Type	Specific Gravity	Correction Factor (CF)
Air	1.00	1.00
Argon	1.38	.85
Dry Carbon Dioxide	1.52	.81
Ethane	1.04	.98
Helium	.14	1.49
Hydrogen	.07	1.02
Krypton	2.82	.59
Methane (pure)	.55	1.35
Natural gas	.60	1.29
Neon	.70	1.20
Nitrogen	.97	1.02
Propane	1.53	.81
Xenon	4.53	.47

To calculate the correction factor for gases not listed on the table above, it will be necessary to know the specific gravity of the gas and use it in the formula listed below:

$$\text{Correction Factor (CF)} = \sqrt{\frac{S.G._1}{S.G._2}}$$

Where:

- SG₁ = Specific Gravity of the gas in which the capacity is published.
- SG₂ = Specific Gravity of the gas to be controlled.

Specifications

Meter Classification	METRIS 250	METRIS RM	METRIS MB
Meter Capacity	250 CFH Natural Gas @ 0.5 inch H ₂ O differential 400 CFH Natural Gas @ 1.0 inch H ₂ O differential		
Meter Type	(TC) Temperature Compensated or (NTC) Non-temperature Compensated		
Index	4 Circle Dial (ft ³ - Standard Pressure, 14 inch H ₂ O, 2 PSIG) 4 Digit Direct Read (ft ³ - Standard Pressure) 5 Digit Direct Read (ft ³ or m ³ - Standard Pressure) ft ³ - 1/2' and 2' proving dial m ³ - 10 dm ³ and 50 dm ³ proving dial Standard = 7 inch H ₂ O @ 14.73 PSIA base/14.4 PSIA atmospheric		
Meter M.A.O.P	5 PSIG		
Regulator M.A.O.P	125 PSIG		
Hub Sizes	#1 Sprague Standard, 10 LT, 20 LT, 30 LT, 1-1/4"		
Inlet Connection	3/4" or 1" Female NPT		
Surface Treatment	ASA 49 Gray Polyester Powder Coating		
Packaging	75 pack/skid		
Measurement Information			
Units	Imperial (Cubic Feet - ft ³)		Metric (Cubic Meters - M ³)
Index Drive	2 cubic feet/revolution		50 cubic decimeters/revolution
Tangent Crank	14 revolutions/cubic feet or 0.071 cubic feet/revolution		0.5 revolutions/cubic decimeter or 2 liters/revolution

Construction	
Center module and Side Covers	Acetal
Cam Crank	Acetal
Flags, Flag Arms & Arm Links	Acetal
Valve Links	Acetal
Retaining Clip, Valve Cover Guides and Gear Shaft	Acetal
Tangent Plate	Die Cast Aluminum
Index Cover	Polycarbonate (Lexan)
IDM Seal	Acetal
IDM Boot	Nitrile
Valve Seat & Covers	Thermoset Phenolic
Diaphragm Plates	Acetal
IDM Shaft, Center Shaft & Flag Shaft	Stainless Steel
Diaphragm Disks	Tin Plated Steel
O-Rings	Nitrile
Outlet Seal	Nitrile
Case Gasket	Cork/Neoprene
Index Gears	Acetal
Index Face Plate	ABS
Top & Bottom Castings	Die Cast Aluminum
Handhole Cover	Stamped Aluminum
Regulator	Die Cast Aluminum (Metris RM only)
RM Manifold	Cast Iron (Metris RM only)
MB Plate	Steel (Metris MB only)

Dimensions

Imperial – inches			
	METRIS 250	METRIS RM	METRIS MB
A	7.7	7.7	7.7
B	11.3	11.0	11.0
C	6.0	2.3	2.3
D	8.8	12.0	12.0
E	6.0	6.0	6.0
F	9.1	12.2	12.2
G		6.8	6.8
H			5.4
I		8.5	8.5
J		0.8	0.8
K		2.4	2.4
Wt. lbs.	8	12	14

Metric - Millimeters			
	METRIS 250	METRIS RM	METRIS MB
A	195	195	195
B	287	279	279
C	152	58	58
D	223	304	304
E	152	152	152
F	231	310	310
G		173	173
H			137
I		216	216
J		20	20
K		61	61
Wt. kg.	3.6	5.4	6.4

METRIS 250

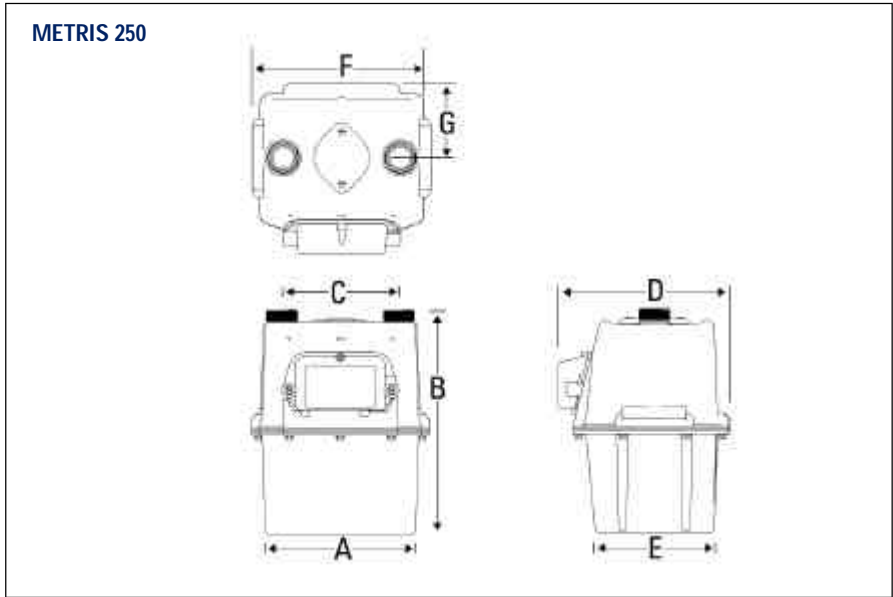

METRIS RM

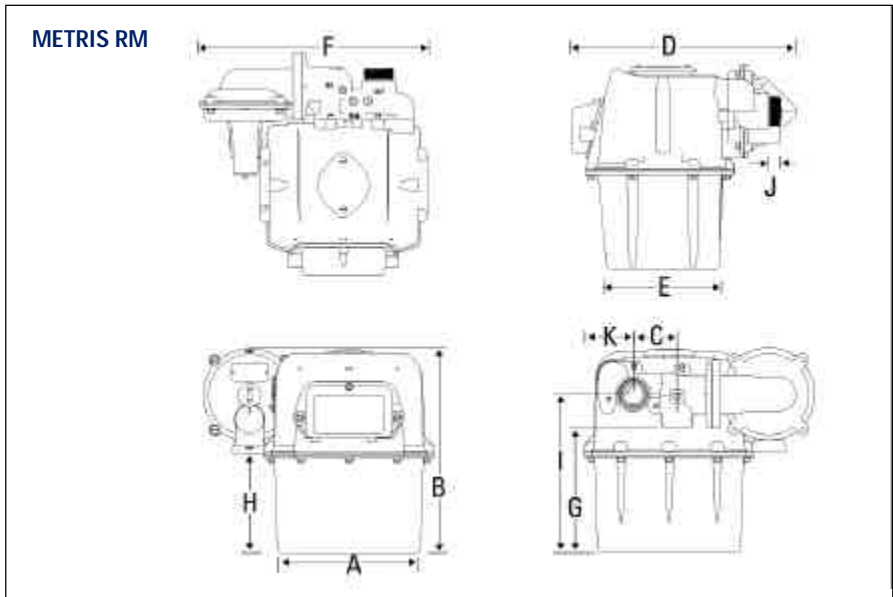

METRIS MB

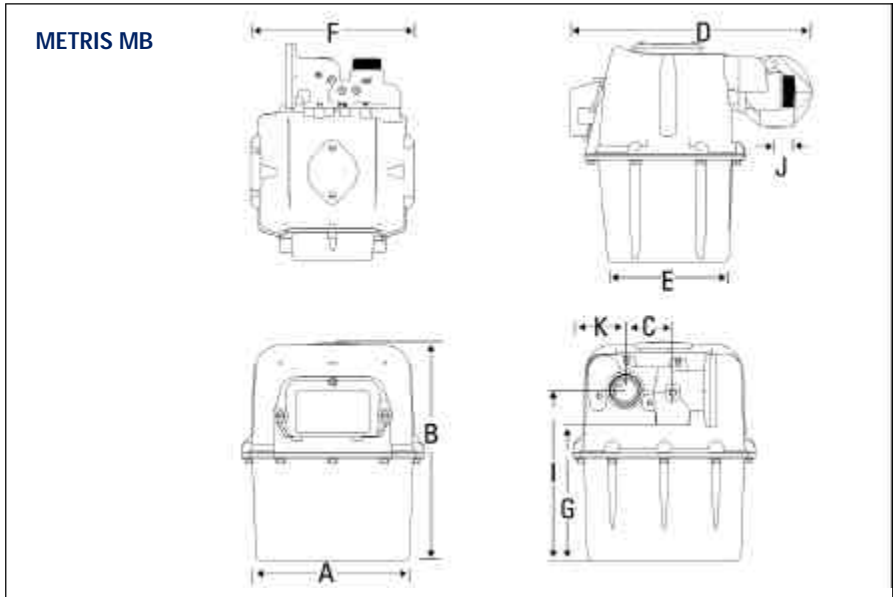



Approvals

- ANSI B109.1
- Industry Canada AG-0393
- State of New York Department of Public Service 97-G-1488
- Maryland Public Service Commission COMAR 20.55.07.02

AMR Compatibility

The Actaris METRIS meter is designed to be compatible with all meter reading systems that use a reading initiator that mounts between the index and the meter.

20 Year Accuracy Assurance

Actaris guarantees that 90% of a shipment of METRIS meters purchased in any 12 month period will be adjustable to within $\pm 1\%$ accuracy for a period of 20 years from the year of purchase. If more than 10% of the meters are not adjustable to $\pm 1\%$, Actaris will repair or replace those meters that cannot be made to conform to the $\pm 1\%$ standard.

Lifetime Case Warranty

The die cast aluminum case of the METRIS meter will be free from manufacturing defects for the life of the meter. In addition, the cast iron manifold and aluminum diaphragm case of the regulator on the METRIS RM meter will also be free from manufacturing defects for the life of the meter/regulator combination.

Capacity & Pressure Loss

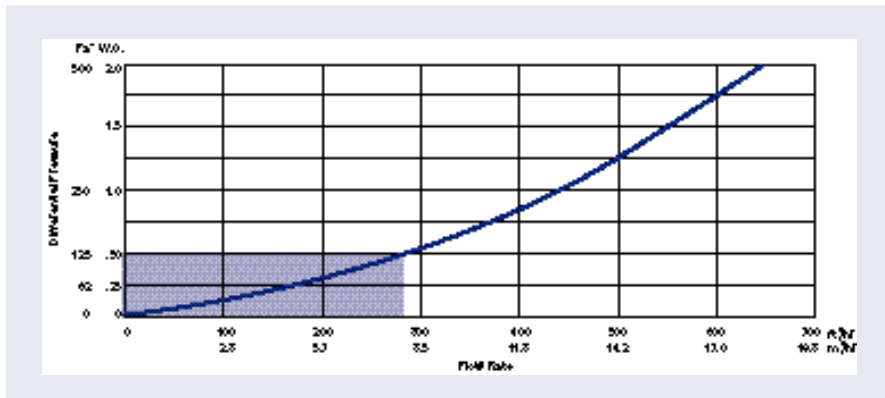

Accelerated Life Test

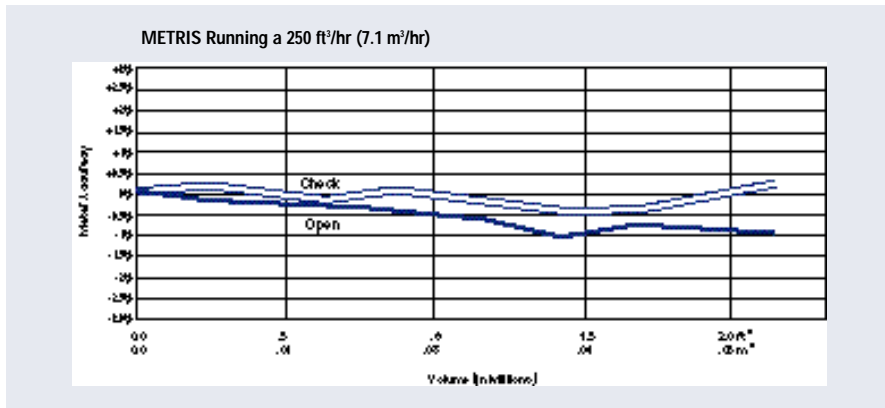

METRIS Meter Adjustment

The adjustment of an Actaris METRIS Meter is now done through the hand hole cover making the adjustment visible. Simply remove the red security seal and 2 screws, then remove the hand hole cover.

A non-temperature compensated tangent can be seen below. The adjustment is the same whether the meter is temperature compensated or non temperature compensated. Rotate the tangent block so it is in the same position as in the diagram below. The only tool needed for adjustment is a 5/16" ignition wrench. Once the meter is in proof, ensure the o-ring is in the groove in the top casting and replace the hand hole cover.

Adjustment Rule: Bring Open to Check, and Check to Spec

Note: One flat of a nut equals one sixth of a full revolution. Nominal wrench throw is half a flat (about 30 degrees of a rotation). If wrench is rotated about its shaft 180 degrees between successive throws, two throws will turn the nut one flat. Move right nut first if a downward wrench throw is required. Move left nut first if an upward wrench throw is required.

Step 1 - Timing Adjustment

Moving timing nuts to the right with a downward motion of the wrench increases the Open rate percent accuracy (Downward Plus). Moving these nuts to the left with an upward motion of the wrench decreases Open rate accuracy. Rotating these nuts one flat produces a .3% change in accuracy.

Step 2 - Displacement Adjustment

Moving displacement nuts to the left with an upward motion of the wrench increases Open and Check rate accuracy together (upward Plus). Moving them to the right with a downward motion of the wrench decreases Open and Check accuracy. Rotating these nuts one flat produces a .5% change in accuracy.

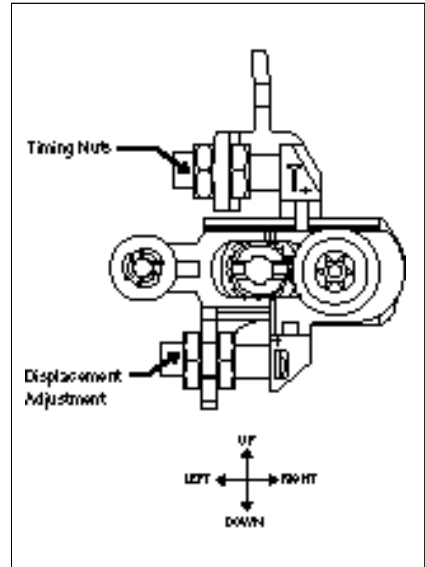

Timing Screw		
	Changes Spread	1 Nut Flat = .3%
	Up (-)	
	Down (+)	
Displacement Screw		
	Changes Open & Check	1 Nut Flat = .5%
	Up (+)	
	Down (-)	
Example:		
	Target (% Accuracy)	Open = 100.0%, Check = 100.0%
	Reading (% Accuracy)	Open = 102.0%, Check = 101.0%
	Proper Adjustment for Timing Screw = 3 flats up	
	Proper Adjustment for Displacement Screw = 2 flats down	



Actaris takes pride in delivering American made products with the utmost concern for quality and customer satisfaction.

Warranty

Actaris U.S. Gas, 970 Highway 127 North, Owenton, Kentucky 40359-9802, warrants this gas product against defects in materials and workmanship for the earlier of one (1) year from the date the product is shipped by Actaris or a period of one year from the date the product is installed by Actaris at the original purchaser's site. During such one-year period, provided that the original purchaser continues to own the product, Actaris will, at its sole option, repair any defects, replace the product or repay the purchase price.

This warranty will be void if the purchaser fails to observe the procedures for installation, operation or service of the product as set forth in the Operating Manual and Specifications for the product or if the defect is caused by tampering, physical abuse or misuse of the product.

Actaris specifically disclaims all implied warranties including those of merchantability or of fitness for a particular purpose. Under no circumstances will Actaris be liable for incidental or consequential damages of any kind whatsoever.

Actaris's liability for any claim of any kind, including negligence and breach of warranty for the sale and use of any product covered by or furnished, shall in no case exceed the price allocable to the product or part thereof which gives rise to the claim.

In the event of a malfunction of the product, consult your Actaris Service Representative or Actaris U.S. Gas, 970 Highway 127 North, Owenton, Kentucky 40359-9802.

Ordering Requirements

1. Capacity of installation (BTU/hr, scfh, etc)
2. Metering pressure
3. Units (Standard or Metric)
4. Hub size
5. Index style
6. Temperature compensation
7. Tamper seals
8. Options

Reference Information

- Parts List GA-0022-GB-08.00
- Price Bulletin AOR
- METRIS Meter Startup Procedure GA-0023-GB-09.00

Follin Flo-Controls

39 Magnolia Avenue, Cambridge MA 02138
5 Heritage Hill Rd, Norwalk, CT 06851
Tel.: +1 617 290 2134, +1 203 845 0593
Fax: +1 240 250-8907, +1 203 846-3825
www.follinfo-controls.com

