

CL838 Series Regulator

Twin Parallel Flow Service Regulators

Description

The CL838 series regulators is a single valve body regulator with large twin diaphragm cases that are pilot loaded to insure a high degree of accuracy during fixed factor measurement. This regulator is ideal for commercial and industrial service regulator applications when installed in compliance with D.O.T. regulations. The CL838 requires an inlet pressure of only 0.5 PSIG above outlet pressure.

Benefits

- > Parallel regulation with regulator and monitor in continuous operation
- > Combined unit saves space and eliminates extra piping
- > Designed to meet D.O.T. service regulator safety standards
- > Accurate, reliable, versatile

Models

- > CL838-1 – Maximum inlet pressure is 150 PSIG; outlet pressure range 6" W.C. to 5 PSIG; orifice size 3/8" to 1 3/8"
- > CL838-2 – Maximum inlet pressure is 150 PSIG; outlet pressure range from 1 PSIG to 30 PSIG; orifice sizes available from 3/8" to 1 3/8"
- > CL838D-1 – (Downstream) Maximum inlet pressure 150 PSIG; outlet pressure range 6" W.C. to 5 PSIG with closed throat and equipped for downstream control tap. This unit is used when it is desirable to control the regulator from a downstream sensing point other than the regulator valve body outlet side
- > CL838D-2 – Maximum inlet pressure is 150 PSIG. Outlet pressure range is from 1 PSIG to 30 PSIG. All other facets of the CL838D-2 are the same as the CL838D-1 regulator. Orifice sizes available are 3/8" through 1 3/8"

- > CL838M-1 – Regulator for monitor installation with closed throat and o-ring seal on the valve stem at the throat to assure positive downstream control when installed ahead of the operating regulator. This unit provides an operating safety device which assumes control over the operating regulator when failure is sensed by the monitor control line. The monitor regulator is set to take over control from the operating regulator with only a slight increase in outlet pressure. Orifice sizes 3/8" through 1 3/8" and outlet pressure range from 6" W.C. to 5 PSIG. And inlet pressures of 150 PSIG max
- > CL838M-2 – Regulator for monitor installations. All facets of this regulator are the same as the CL838M-1 except the range of outlet pressures which are from 1PSIG to 30 PSIG
- > CL838IM – is a single valve body regulator with large (12 1/16" dia.) twin diaphragm cases pilot loaded to insure a high degree of accuracy during fixed factor measurement. The internal monitor features the safety advantage of a second gas tight backup seat if the normal orifices' face and valve seats fail to contain the outlet pressure at the adjusted outlet pressure level. It also controls the gas flow between the failed open flow and no flow conditions, thus creating secondary regulation
- > CL838IM-1 – has a maximum inlet pressure of 125 PSIG and an outlet pressure range from 6 inches of water column to 5 PSIG. Orifice sizes are available from 3/8" to 1"
- > CL838IM-2 – has a maximum inlet pressure of 125 PSIG and an outlet pressure range from 1 PSIG to 30 PSIG. Orifice sizes are available from 3/8" to 1"



CL838 Series Twin Parallel Flow Service Regulators

Shipping weight

One regulator per box

Size	Box weight
2" x 2" NPT	88 lbs.
2" x 2" Flanged	98 lbs.
2" x 3" Flanged	115 lbs.
2" x 4" Flanged	125 lbs.

CL838 Dimensions

Valve body	A	B	C	D	E	F	G	H
1-1/2-inch, 2-inch, or 3-inch	9-5/8	13	2-3/16	37-3/4	18-7/8	12-3/4	7-3/8 (max.)	25

Pilot Dimensions

Pilot	X	Y
1	6-1/2	13
2	6-3/4	13-1/2

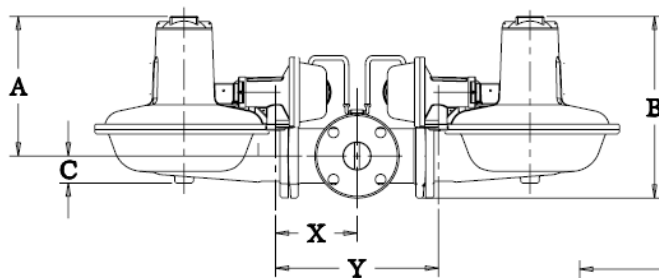

Horizontal mounting view

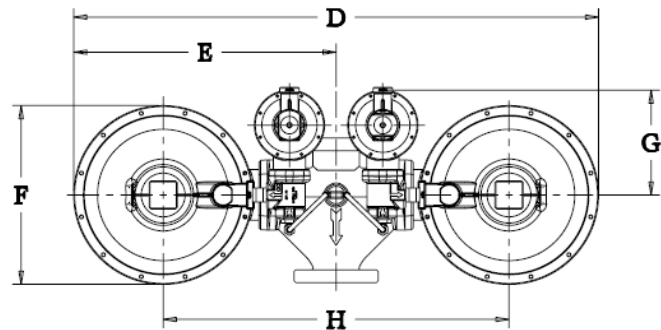

Alternate assembly position shown with pilots rotated 90°

Operational Schematic

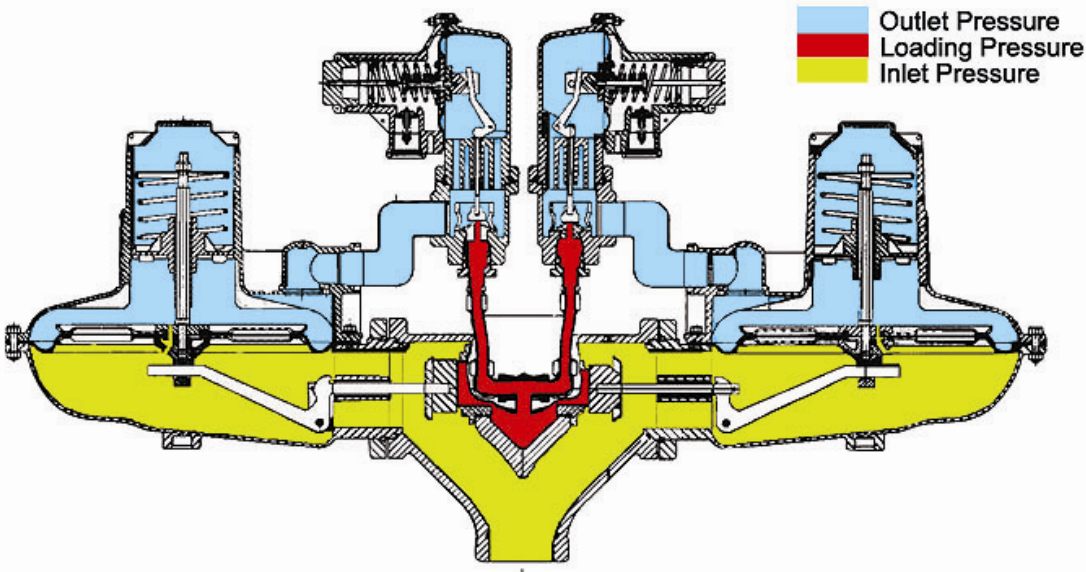

Note: valve shown closed position.

Spring Data - Spring Color Outlet Pressure Range

CL-838 - 1¹

Closing spring outlet pressure range			
Pilot loading spring	Orange	Brown	Black
Green/white	5.6 - 8.1" w.c.	-	-
Blue/white	8.2 - 16.6" w.c.	5.3 - 12.8" w.c.	-
Dark green	13.3 - 18.2" w.c.	8.6 - 14.8" w.c.	6.6 - 7.0" w.c.
Silver/white	0.75 - 1.5 PSIG	0.5-1.35 PSIG	9.3 - 29.0" w.c.
Yellow/white	1.8 - 2.7 PSIG	1.7 - 2.5 PSIG	1.5 - 2.2 PSIG
Red/white	2.6 - 4.6 PSIG	2.4 - 4.3 PSIG	2.2 - 4.0 PSIG
White	3.8 - 5.0 PSIG	3.3 - 5.0 PSIG	3.2 - 5.0 PSIG

CL838 - 2²

Brown	0.8 - 2.7 PSIG	0.8 - 2.2 PSIG	0.8 - 1.8 PSIG
Green	1.5 - 9.5 PSIG	1.5 - 9.5 PSIG	1.5 - 8.0 PSIG
Black	5.0 - 14.8 PSIG	5.0 - 14.6 PSIG	5.0 - 14.3 PSIG
Blue	9.0 - 29 PSIG	9.0 - 29 PSIG	9.0 - 29 PSIG
Silver	25 - 30 PSIG	25 - 30 PSIG	25 - 30 PSIG

CL-838-1 IM

	Green	Black
Blue/white	4.5 - 10.0" w.c.	-
Dark green	11.0 - 14.3" w.c.	4.0 - 6.2" w.c.
Silver/white	0.5 - 1.2 PSIG	6.0 - 21.4" w.c.
Yellow/white	1.6 - 2.3 PSIG	1.3 - 1.9 PSIG
Red/white	2.1 - 3.8 PSIG	1.9 - 3.4 PSIG
White	3.0 - 5.0 PSIG	3.0 - 5.0 PSIG

CL-838-2-IM

Brown	0.75 - 2.1 PSIG	0.75 - 1.8 PSIG
Green	1.5 - 10.0 PSIG	1.5 - 9.2 PSIG
Black	5.0 - 12.9 PSIG	5.0 - 12.0 PSIG
Blue	9.0 - 30.0 PSIG	9.0 - 30.0 PSIG

*Spring Ranges are approximate and may vary by application.

¹ The maximum recommended outlet pressure from a CL-838-1 and CL-838-1IM is 5 PSIG.

²The maximum recommended outlet pressure from a CL-838-2 CL-838-2IM is 30 PSIG.

**Springs are not interchangeable between CL838 and CL838 IM.

Orifice Data - Wide Open Flow Coefficients and Maximum Pressure Data

Orifice Size (inches)	K-factors	Maximum Operating Inlet Pressure R Models		Max Emergency Inlet Pressure	Max. Emergency Outlet Pressure (containment)	
		In w.c. delivery	PSIG delivery	All Outlet	In w.c. delivery	PSIG delivery
		Pressure PSIG	Pressure PSIG	Inlet Pressure PSIG		
3/8	6	125	125	150% of the maximum pressure of the closing spring differential	40	40
1/2	11	125	125			
5/8	14.5	125	125			
3/4	20	125	125			
1	29	100	100			
1-1/4	34	75	75			
1-3/8		75	75			

Operating Temperature

- 20°F to 150°F

Additional Specifications

Available pilot vent sizes	3/4"
Loading ring position	For outlet pressure \geq 1PSIG: 0° For outlet pressure $<$ 1 PSIG: 25°
Other available options	Seal wire to indicate unapproved tampering
	1/4" pipe plug tap on upstream side of valve body
	Pilot supply line filter (contact Itron, Owenton KY for specifications)
	Stainless steel supply line fittings

Itron takes pride in delivering American made products with the utmost concern for safety, quality, and customer satisfaction.

Material construction:

Valve bodies	High tensile strength cast iron (ASTM A-126, Class A)
Orifices	Aluminum
Valve seats	Buna-N
Valve stems	Nylon
Lever pins	Stainless steel (type 303)
Levers	Zinc and dichromate plated steel (AISI C1010)
Upper diaphragm plates	Zinc and dichromate plated steel (14-gauge steel)
Lower diaphragm plates	Die cast aluminum (ASTM B-85 Alloy SC84A)
Diaphragms	Buna-N reinforcing fiber
Vent valves/seats	Neoprene
Vent screen	Stainless steel (16 mesh)
Adjustment ferrules	Acetal
Seal caps	ABS plastic
Diaphragm cases	Die cast aluminum (ASTM B85 - Alloy SC84A)
Valve stem inserts	Acetal

Valve Body Sizes

Inlet	Outlet	SCR	Flanged
2"	2"	X	X
2"	3"		X
2"	4"		x

X indicates the valve body is available in that configuration.

Correction factors for non-natural gas applications

The CL838 may be used to control gases other than natural gas. To determine the capacity for gases other than natural gas, multiply the values within the capacity tables by a correction factor. The table below lists the correction factors for some of the more common gases:

Gas Type	Specific Gravity	Correction Factor (CF)
Air	1.00	0.77
Butane	2.01	0.55
Carbon Dioxide (Dry)	1.52	0.63
Carbon Monoxide (Dry)	0.97	0.79
Natural Gas	0.60	1.00
Nitrogen	0.97	0.79
Propane	1.53	0.63
Propane-Air-Mix	1.20	0.71

To calculate the correction factor for gases not listed in the table above, use the gases' specific gravity and insert it in the formula listed below:

$$\text{Correction Factor (CF)} = \sqrt{\frac{SG_1}{SG_2}}$$

Where:

SG₁ = Specific gravity of the gas in which the capacity is published.

SG₂ = Specific gravity of the gas to be controlled.

Wide Open Flow Calculations

For wide-open orifice flow calculations use the following equations:

$$\text{For } P_1/P_2 < 1.89 \text{ use: } Q = K \sqrt{P_2(P_1 - P_2)}$$

$$\text{For } P_1/P_2 > 1.89 \text{ use: } Q = \frac{KP_1}{2}$$

Where: P₁ = Absolute Inlet Pressure (PSIA)
Q = Flow Rate (SCFH)

P₂ = Absolute Outlet Pressure (PSIA)
K = Orifice Coefficient (SCFH/PSI)

CL838 Capacity Table 2 x 2

Capacities based on 0.6 Sp. Gr. gas at 14.7 PSIA and 60°F.

Typical Capacity Info.	
Manufacturer	Itron
Type and model	CL838
Regulator	
Inlet size	2-inch SCR 2-inch Flanged
Outlet size	2-inch Flanged
Spring color	Varies

Orifice Size		3/8	1/2	5/8	3/4	1	1-1/4	1-3/8
Inlet Pressure PSIG	Outlet Pressure (PSIG)	Orifice constant factor K						
		510	780	990	1350	1850	2280	2510
2	7" w.c.	2.55	3.55	4.55	6.0	8.65	10.0	11.7
	11" w.c.	2.55	3.5	4.5	5.95	8.35	1.7	11.3
	1	2.1	2.95	3.75	4.8	6.9	8.05	9.3
	1.5	1.65	2.4	3.35	4.3	5.6	7.0	7.95
3	7" w.c.	3.15	4.2	5.8	7.5	10.6	12.7	14.4
	11" w.c.	2.95	4.2	5.8	7.35	10.4	12.5	14.1
	1	2.8	3.9	5.2	6.65	9.45	11.2	12.7
	2	2.15	3.0	4.1	5.15	7.1	8.55	9.7
5	7" w.c.	4.05	5.65	7.65	9.75	13.9	17.0	18.8
	11" w.c.	4.05	5.65	7.55	9.65	13.7	16.8	18.6
	1	3.8	5.65	7.2	9.2	13.1	16.0	17.7
	2	3.45	5.25	6.5	8.3	11.8	14.4	15.9
10	7" w.c.	5.8	8.45	10.8	13.9	19.7	24.2	26.7
	11" w.c.	5.8	8.45	10.8	13.8	19.7	24.1	26.6
	1	5.7	8.35	10.7	13.7	19.4	23.8	26.3
	2	5.55	8.1	10.4	13.3	18.9	23.2	25.6
15	5	4.8	7.0	9.05	11.5	16.4	20.1	22.2
	8	3.35	4.95	6.35	8.1	11.5	14.1	15.6
	1 or less	7.05	10.3	13.3	17.0	24.2	29.7	32.8
	2	7.0	10.3	13.2	16.9	24.0	29.5	32.6
20	5	6.75	9.85	12.6	16.2	23.0	28.2	31.1
	8	6.05	8.9	11.4	14.6	20.8	25.4	28.1
	10	5.35	7.9	10.1	13.0	18.4	22.6	25.0
	13	3.75	5.5	7.1	9.05	12.9	15.8	17.4
20	3.5 or less	8.2	12.1	15.6	19.9	28.3	34.7	38.3
	5	8.15	12.0	15.4	19.7	28.1	34.4	38.0
	10	7.5	11.0	14.2	18.2	25.8	31.6	34.9
	15	5.9	8.7	11.2	14.3	20.3	24.9	27.5
20	18	4.1	6.05	7.8	9.95	14.1	17.3	19.1

K values are wide open for each orifice size.

Figures below heavy line may show differentials above allowable limits. Check closing spring tables to confirm.

Loading Ring set at 0° for PSIG outlet pressures. Loading ring set at 25° for inches w.c. outlet pressures. Exact settings may vary with individual pressure and load condition applications.

All capacities at 1% outlet pressure absolute pressure drop.

Set point at each outlet pressure was 500 cfh.

CL838 Capacity Table 2 x 2 (continued)

Capacities based on 0.6 Sp. Gr. gas at 14.7 PSIA and 60°F.

Orifice Size		3/8	1/2	5/8	3/4	1	1-1/4	1-3/8
Inlet Pressure PSIG	Inlet Pressure PSIG	Orifice constant factor K						
		550	930	1290	1610	2075	2515	2710
30	9 or less	10.6	15.6	20.1	25.7	36.4	44.7	49.3
	10	10.5	15.5	20.0	25.5	36.3	44.5	49.1
	15	10.0	14.8	19.0	24.3	34.6	42.4	46.8
	20	8.95	13.1	16.9	21.6	30.7	37.7	41.6
	25	6.9	10.1	13.1	16.7	23.7	29.1	32.1
40	14 or less	12.9	19.1	24.6	31.4	44.6	54.7	60.4
	15	12.9	19.0	24.5	31.3	44.5	54.5	60.2
	20	12.5	18.5	23.7	30.4	43.1	52.8	58.4
	30	10.2	15.0	19.3	24.7	35.4	43.0	47.5
50	19.5 or less	15.3	22.6	29.1	37.2	52.8	64.7	71.4
	20	15.3	22.6	29.0	37.1	52.7	64.5	71.3
	30	14.2	21.0	27.0	34.5	49.1	60.1	66.4
60	24.5 or less	17.7	26.1	33.6	42.9	60.9	74.7	82.5
	25	17.7	26.1	33.5	42.8	60.9	74.5	82.4
	30	17.4	25.6	33.0	42.2	59.9	73.4	81.1
75	30 or less	21.3	31.1	40.3	51.5	73.2	89.7	99.0
100	30 or less	27.2	40.1	51.6	65.9	93.6		
125	30 or less	33.1	48.8	62.8	80.3			

K values are wide open for each orifice size.

Figures below heavy line may show differentials above allowable limits. Check closing spring tables to confirm.

Loading Ring set at 0° for PSIG outlet pressures. Loading ring set at 25° for inches w.c. outlet pressures. Exact settings may vary with individual pressure and load condition applications.

All capacities at 1% outlet pressure absolute pressure drop.

Set point at each outlet pressure was 500 cfh.

Maximum recommended inlet pressure - PSI to inches regulation - left of heavy black line.

Do not operate orifice in shaded inlet pressure area.

CL838 Capacity Table 2 x 3

Capacities based on 0.6 Sp. Gr. gas @ 14.7 PSIA and 60°F.

Orifice size (inches)		3/8	1/2	5/8	3/4	1	1-1/4	1-3/8
Inlet Pressure PSIG	Inlet Pressure PSIG	Orifice constant factor K						
		550	930	1290	1610	2075	2515	2710
2	7" W.C.	2.7	4.3	5.6	7.45	9.9	12.4	13.5
	11" W.C.	2.6	4.15	5.4	7.2	9.6	12.0	13.0
	1	2.1	3.45	4.5	5.95	7.95	9.95	10.8
	1.5	1.75	2.65	3.65	4.7	6.1	7.65	8.3
3	7" W.C.	3.4	5.6	7.1	9.2	12.4	15.3	16.6
	11" W.C.	3.35	5.5	6.95	9.0	12.1	15.0	16.3
	1	3.0	4.9	6.3	8.15	11.0	13.6	14.7
	2	2.25	3.6	4.75	6.15	8.3	10.3	11.1
5	7" W.C.	4.5	7.3	9.35	12.3	16.3	20.2	22.3
	11" W.C.	4.45	7.2	9.25	12.2	16.2	20.0	22.0
	1	4.25	6.85	8.8	11.6	15.4	19.0	21.0
	2	3.7	6.1	7.95	10.4	13.9	17.1	18.9
10	3	3.2	5.15	6.75	8.95	11.8	14.6	16.1
	7" W.C.	6.45	10.2	13.9	18.1	23.6	28.7	31.7
	11" W.C.	6.45	10.2	13.8	18.1	23.5	27.6	31.6
	1	6.35	10.1	13.7	17.8	23.2	28.3	31.2
15	2	6.2	9.85	13.3	17.4	22.6	27.5	30.4
	5	5.2	8.55	11.5	15.1	19.6	23.9	26.3
	8	3.6	6.0	8.1	10.6	13.7	16.8	18.5
	1 or less	7.95	13.3	17.8	23.0	29.3	35.2	38.9
	2	7.9	13.2	17.7	22.8	29.1	35.0	38.6
	5	7.5		16.9	21.8	27.8	33.4	36.9
20	8	6.75	11.4	15.2	19.7	25.1	30.2	33.3
	10	5.95	10.1	13.5	17.5	22.3	26.9	29.6
	13	4.0	7.1	9.45	12.2	15.6	18.7	20.7
	3.5 or less	9.4	15.6	21.1	27.3	34.7	41.2	45.4
	5	9.3	15.4	21.0	27.1	34.4	40.8	45.1
20	10	8.5	14.2	19.3	24.9	31.6	37.5	41.4
	15	6.6	11.2	15.2	19.6	24.9	29.6	32.6
	18	4.4	7.8	10.5	13.6	17.3	20.6	22.7

Maximum recommended inlet pressure - PSI to inches regulation.

Set point at each outlet pressure was 500 cfh.

Loading ring set at 0° for PSIG outlet pressures. Loading ring set at 25° for inches w.c. outlet pressures. Exact settings may vary with individual applications of pressures and load conditions.

K factors are wide open for each orifice size.

CL838 Capacity Table 2 x 3 continued

Capacities base on 0.6 Sp. Gr. gas @ 14.7 PSIA and 60°F.

Orifice size (inches)		3/8	1/2	5/8	3/4	1	1-1/4	1-3/8
Inlet Pressure PSIG	Inlet Pressure (PSIG)	Orifice constant factor K						
		550	930	1290	1610	2075	2515	2710
30	9 or less	12.2	20.1	27.4	35.2	44.7	53.4	58.5
	10	12.1	20.0	27.3	35.0	44.5	53.1	58.2
	15	11.5	19.0	26.0	33.4	42.4	50.6	55.5
	20	10.2	16.9	23.1	29.6	37.7	45.0	49.3
	25	7.7	13.1	17.9	22.9	29.1	34.8	38.1
40	14 or less	14.9	24.6	33.9	43.0	54.7	65.3	71.6
	15	14.9	24.5	33.8	42.9	54.5	65.1	71.4
	20	14.4	23.7	32.7	41.6	52.8	63.1	69.2
	30	11.5	19.3	26.6	33.8	43.0	51.3	56.3
50	19.5 or less	17.7	29.1	40.1	50.9	64.7	77.3	84.7
	20	17.6	29.0	40.0	50.8	64.5	77.1	84.5
	30	16.3	27.0	37.3	47.3	60.1	71.8	78.8
60	24.5 or less	20.4	33.6	46.3	58.8	74.7	89.2	97.8
	25	20.3	33.5	46.2	58.7	74.5	89.1	97.7
	30	20.0	33.0	45.5	57.8	73.4	87.7	96.1
75	30 or less	24.5	40.3	55.6	70.6	90.0	107.1	117.5
100	30 or less	31.3	51.6	71.1	90.2	115.0		
125	30 or less	38.1	62.8	86.6	109.0			

Maximum recommended inlet pressure - PSI to inches regulation - left of heavy black line.

Set point at each outlet pressure was 500 cfh.

Loading ring set at 0° for PSIG outlet pressures. Loading ring set at 25° for inches W.C. outlet pressures. Exact settings may vary with individual applications of pressures and load conditions.

K factors are wide open for each orifice size.

 Do not operate orifice in shaded inlet pressure area.

CL838 Capacity Table 2 x 4

Capacities base on 0.6 Sp. Gr. gas @ 14.7 PSIA and 60°F.

Orifice size (inches)		3/8	1/2	5/8	3/4	1	1-1/4	1-3/8
Inlet Pressure PSIG	Inlet Pressure PSIG	Orifice constant factor K						
		565	950	1350	1710	2190	2625	3050
2	7" W.C.	2.85	4.6	6.25	8.2	11.0	13.3	14.3
	11" W.C.	2.8	4.55	6.25	7.9	10.7	12.9	13.8
	1	2.35	3.7	5.1	6.55	8.8	10.6	11.4
	1.5	1.85	3.1	4.2	5.3	7.0	8.2	8.8
3	7" W.C.	3.55	5.75	7.95	10.1	13.6	16.3	19.7
	11" W.C.	3.5	5.7	7.8	9.9	13.4	16.0	19.4
	1	3.25	5.05	7.05	8.9	12.1	14.4	18.5
	2	2.3	4.0	5.35	7.05	9.15	10.9	13.1
5	7" W.C.	4.65	7.7	10.2	13.1	17.7	21.6	25.7
	11" W.C.	4.65	7.6	10.1	13.0	17.6	21.5	25.5
	1	4.35	7.15	9.65	12.4	16.6	20.5	23.4
	2	3.95	6.55	8.7	11.2	15.0	17.9	19.9
	3	3.35	5.55	7.45	9.55	12.3	15.6	17.5
10	7" W.C.	6.7	10.8	15.4	20.4	25.9	30.2	35.8
	11" W.C.	6.7	10.8	15.4	20.4	25.9	30.1	35.5
	1	6.6	10.6	15.1	20.1	25.5	29.7	35.0
	2	6.4	10.3	14.7	19.5	24.8	28.9	34.1
	5	5.4	8.95	12.8	16.9	21.5	25.0	29.5
	8	3.8	6.3	9.0	11.9	15.1	17.6	20.7
15	1 or less	8.3	13.8	19.0	24.6	31.1	37.8	43.0
	2	8.25	13.7	18.8	24.4	30.8	37.5	42.7
	5	7.85	13.0	17.9	23.3	30.1	35.8	40.8
	8	7.1	11.8	16.2	21.0	27.2	32.4	30.9
	10	6.3	10.5	14.4	18.7	24.2	28.8	32.8
	13	4.4	7.3	10.0	13.0	16.9	20.1	22.9
20	3.5 or less	9.65	16.0	22.5	28.7	37.3	44.2	50.3
	5	9.6	15.8	22.3	28.4	36.8	43.8	49.9
	10	8.8	14.5	20.5	26.1	33.8	40.3	45.9
	15	6.95	11.5	16.1	20.6	26.6	31.7	36.1
	18	4.85	8.0	11.2	14.3	18.5	22.1	25.1

Maximum recommended inlet pressure - PSI to inches regulation.

Set point at each outlet pressure was 500 cfh.

Loading ring set at 0° for PSIG outlet pressures. Loading ring set at 25° for inches W.C. outlet pressures. Exact settings may vary with individual applications of pressures and load conditions.

K factors are wide open for each orifice size.

CL838 Capacity Table 2 x 4 continued

Capacities base on 0.6 Sp. Gr. gas @ 14.7 PSIA and 60°F.

Orifice size (inches)		3/8	1/2	5/8	3/4	1	1-1/4	1-3/8
Inlet Pressure PSIG	Inlet Pressure PSIG	Orifice constant factor K						
		565	950	1350	1710	2190	2625	3050
30	9 or less	12.4	20.6	29.0	36.9	48.0	56.9	64.8
	10	12.4	20.5	28.8	36.8	47.7	56.6	64.5
	15	11.8	19.8	27.5	35.0	45.4	53.9	61.5
	20	10.5	17.3	24.4	31.2	40.4	48.0	54.6
	25	8.1	13.4	18.8	24.1	31.2	37.0	42.2
40	14 or less	15.2	25.7	35.5	45.2	58.8	70.4	79.3
	15	15.2	25.6	35.4	45.1	58.5	70.1	79.0
	20	14.7	24.5	34.3	43.7	56.7	68.0	76.6
	30	12.0	19.9	27.9	35.5	46.1	55.3	62.3
50	19.5 or less	18.0	30.4	42.0	53.5	69.5	82.4	93.8
	20	18.0	30.3	41.9	53.4	69.2	82.2	93.6
	30	16.8	27.9	39.0	49.7	64.5	76.6	87.2
60	24.5 or less	20.8	35.1	48.5	61.8	80.9	95.2	108.3
	25	20.8	34.9	48.4	61.7	80.0	95.0	108.1
	30	20.5	34.1	47.6	60.7	78.7	93.4	106.4
75	30 or less	25.0	42.1	58.3	74.2	96.4	114.3	130.0
100	30 or less	32.0	53.9	74.5	94.9	123.3		
125	30 or less	39.0	65.6	90.8	115.6			

Maximum recommended inlet pressure - PSI to inches regulation - left of heavy black line.

Set point at each outlet pressure was 500 cfh.

Loading ring set at 0° for PSIG outlet pressures. Loading ring set at 25° for inches w.c. outlet pressures. Exact settings may vary with individual applications of pressures and load conditions.

K factors are wide open for each orifice size.

 Do not operate orifice in shaded inlet pressure area.

Principle of Operation

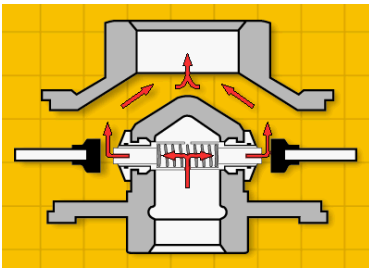

A. Normal regulation

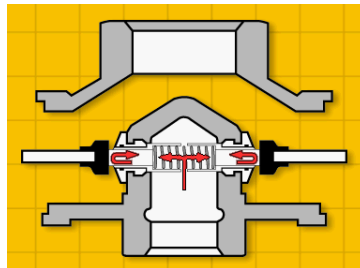

B. Normal lock-up

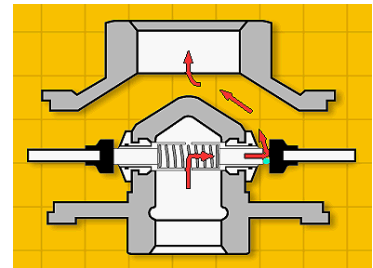

C. Dual monitor operation - internal foreign material failure

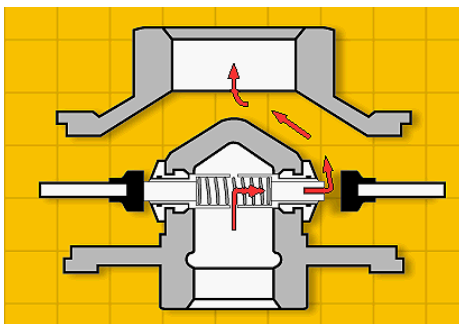

D. Single monitor operation - full internal diaphragm case failure

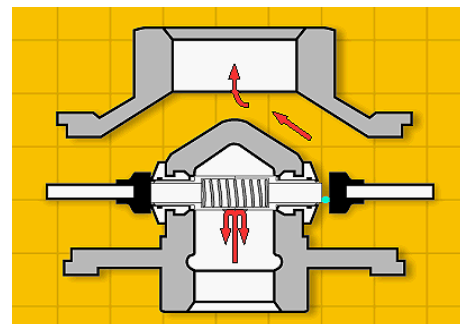

E. Total lock-up

Principle of Operation

A. Normal regulation. The internal monitor orifice operates like a standard one-piece orifice, performing normal regulation.

B. Normal lock-up. The regulator is free to lock-up in the usual manner. The O-ring seal prevents gas from leaking past the orifice exterior into the downstream or low pressure side of the valve body.

C. Dual monitor operation - internal foreign material failure. If the regulator fails to lock-up for any reason, the internal monitor orifice automatically goes into operation. Outlet pressure increases slightly, causing the valve seat to push against the inner or sliding part of the orifice gradually compressing the monitor spring and closing the secondary or monitor orifice on the inlet side of the sliding orifices. At this point, the B-838-IM functions as a monitor regulator. For example, assume a weld bead is caught between the orifice and the valve seat while the regulator is in high-flow operation. If the flow is reduced, the valve tries to close but can't due to the foreign matter. The outlet pressure increases approximately 2" w.c. above the original set point which starts to close the secondary monitor orifice. If the gas demand is decreased, the monitor orifice will partially close and become the new operating orifice. The new orifice will function as a monitor regulator and keep the outlet pressure approximately 3" above the set pressure on inches water column, or .8 PSIG when set for PSIG outlet. If the flow becomes further reduced to no-flow, then the sliding orifice (or orifices) close against the secondary rubber seat providing a complete no-gas flow with a total outlet pressure build up of only 6" w.c. above the original set point.

D. Single monitor operation - one full internal diaphragm case failure. If the diaphragm case is damaged on one side of the piping such that the lever and valve seat cannot move to close against the orifice face, the outlet pressure builds (as described in C) on the good regulator and its sliding orifice moves to contact the non-movable failed orifice monitor seat. Closing or lock-up will be restricted according to flow demand. Since only one diaphragm is in operation, the outlet overpressure will be approximately 4" w.c. higher on single monitor operation than normal regulation set.

E. Total lock-up. If demand for gas downstream of regulator is zero, the sliding orifice (or orifices) will close against the secondary rubber monitor seat and lock-up the gas flow completely.

CL838 IM Capacity Table 2 x 2 SCFH x 1000

Capacities based on 0.6 Sp. Gr. gas at 14.7 PSIA and 60°F.

Typical Capacity Info.

Manufacturer	Itron
Type and model	CL838 IM
Regulator	
Inlet size	2-inch SCR 2-inch Flanged
Outlet size	2-inch SCR 2-inch Flanged
Spring color	Varies

Orifice Size		3/8"	1/2"	5/8"	3/4"	1"
Inlet Pressure PSIG	Outlet Pressure PSIG	Orifice constant factor K				
		510	630	910	1140	1360
2	7" w.c.	2.4	3.1	4.45	5.2	6.35
	11" w.c.	2.35	3.0	4.35	5.1	6.15
	1	1.9	2.45	3.55	4.1	5.05
	1.5	1.5	1.95	2.8	3.2	3.9
3	7" w.c.	2.95	3.8	5.55	6.5	7.85
	11" w.c.	2.9	3.75	5.4	6.4	7.65
	1	2.65	3.35	4.9	5.75	6.9
	2	2.0	2.55	3.7	4.4	5.25
5	7" w.c.	3.85	4.95	7.2	8.5	10.2
	11" w.c.	3.8	4.9	7.1	8.4	10.1
	1	3.65	4.7	6.8	8.0	9.6
	2	3.25	4.2	6.1	7.2	8.65
10	7" w.c.	5.5	7.05	10.2	12.2	14.5
	11" w.c.	5.5	7.05	10.2	12.1	14.4
	1	5.4	6.95	10.1	12.0	14.3
	2	5.25	6.8	9.85	11.7	13.9
15	5	4.55	5.85	8.5	10.1	12.0
	8	3.2	4.1	5.95	7.1	8.45
	1 or less	6.95	8.8	12.7	14.9	17.7
	2	6.9	8.75	12.6	14.9	17.6
20	5	6.6	8.35	12.1	14.2	16.8
	8	6.0	7.55	10.9	12.8	15.2
	10	5.3	6.7	9.7	11.4	13.5
	13	3.7	4.7	6.75	7.95	9.4
20	3.5 or less	8.15	10.4	15.1	17.6	20.9
	5	8.1	10.3	14.9	17.5	20.7
	10	7.45	9.45	13.7	16.1	19.0
	15	5.85	7.45	10.8	12.7	15.0
20	18	4.05	5.2	7.55	8.85	10.4

K values are wide open for each orifice size.

Loading Ring set at 0° for PSIG outlet pressures. Loading ring set at 25° for inches w.c. outlet pressures. Exact settings may vary with individual pressure and load condition applications.

All capacities at 1% outlet pressure absolute pressure drop.

Set point at each outlet pressure was 500 cfh.

CL838 IM Capacity Table 2 x 2 SCFH x 1000 (continued)

Capacities based on 0.6 Sp. Gr. gas at 14.7 PSIA and 60°F.

Orifice Size		3/8"	1/2"	5/8"	3/4"	1"
Inlet Pressure PSIG	Outlet Pressure PSIG	Orifice constant factor K				
		510	630	910	1140	1360
30	9 or less	10.7	13.4	19.5	22.9	26.9
	10	10.6	13.3	19.4	22.8	26.8
	15	10.1	12.7	18.5	21.7	25.5
	20	9.05	11.3	16.4	19.3	22.7
	25	6.95	8.7	12.7	14.9	17.5
40	14 or less	13.4	16.6	24.0	28.0	
	15	13.3	16.6	24.0	27.9	
	20	12.9	16.1	23.2	27.0	
	30	10.5	13.1	18.9	22.0	
50	19.5 or less	15.8	19.7	28.4	33.1	
	20	15.8	19.6	28.4	33.0	
	30	14.7	18.3	26.4	30.8	
60	24.5 or less	18.3	22.7	32.8	38.3	
	25	18.3	22.7	32.8	38.2	
	30	17.9	22.3	32.3	37.6	
75	30 or less	22.0	27.3			
100	30 or less	28.1	34.9			
125	30 or less	34.2	42.6			

K values are wide open for each orifice size.

Maximum recommended Inlet Pressure – PSI to inches regulation – left of shaded area.

Loading Ring set at 0° for PSIG outlet pressures. Loading ring set at 25° for inches w.c. outlet pressures. Exact settings may vary with individual pressure and load condition applications.

All capacities at 1% outlet pressure absolute pressure drop.

Set point at each outlet pressure was 500 cfh.

Do not operate orifice in shaded inlet pressure area.

CL838 IM Capacity Table 2 x 3 SCFH x 1000

Capacities based on 0.6 Sp. Gr. gas at 14.7 PSIA and 60°F.

Typical Capacity Info.

Manufacturer	Itron
Type and model	CL838 IM
Regulator	
Inlet size	2-inch SCR 2-inch Flanged
Outlet size	2-inch SCR 2-, 3-, 4-inch Flanged
Spring color	Varies

Orifice Size		3/8"	1/2"	5/8"	3/4"	1"
Inlet Pressure PSIG	Outlet Pressure PSIG	Orifice constant factor K				
		535	690	960	1175	1430
2	7" w.c.	2.55	3.2	4.6	5.8	6.85
	11" w.c.	2.45	3.2	4.5	5.75	6.6
	1	2.05	2.65	3.8	4.6	5.5
	1.5	1.6	2.25	3.35	3.85	4.2
3	7" w.c.	3.15	4.05	5.95	7.1	8.55
	11" w.c.	3.1	4.0	5.85	7.1	8.4
	1	2.8	3.65	5.25	6.45	7.55
	2	2.1	2.8	4.2	4.65	5.75
5	7" w.c.	4.1	5.45	7.85	9.35	11.1
	11" w.c.	4.05	5.45	7.8	9.25	11.0
	1	3.9	5.25	7.35	8.8	10.5
	2	3.5	4.6	6.5	7.95	9.45
10	7" w.c.	6.05	8.0	11.0	13.4	15.8
	11" w.c.	6.0	8.0	11.0	13.4	15.8
	1	6.0	7.9	10.9	13.3	15.6
	2	5.8	7.75	10.6	12.9	15.2
15	5	5.0	6.65	9.2	11.2	13.1
	8	3.5	4.7	6.45	7.8	9.25
	1 or less	7.6	9.85	13.5	16.5	19.6
	2	7.5	9.8	13.4	16.4	19.4
20	5	7.25	9.3	12.8	15.7	18.6
	8	6.55	8.45	11.6	14.2	16.8
	10	5.8	7.5	10.3	12.6	14.9
	13	4.05	5.25	7.2	8.8	10.4
20	3.5 or less	8.9	11.5	15.9	19.5	23.2
	5	8.85	11.4	15.8	19.3	23.0
	10	8.15	10.5	14.5	17.8	21.2
	15	6.4	8.25	11.4	14.0	16.7
20	18	4.45	5.75	7.95	9.75	11.6

K values are wide open for each orifice size.

Loading Ring set at 0° for PSIG outlet pressures. Loading ring set at 25° for inches w.c. outlet pressures. Exact settings may vary with individual pressure and load condition applications.

All capacities at 1% outlet pressure absolute pressure drop.

Set point at each outlet pressure was 500 cfh.

CL838 IM Capacity Table 2 x 3 SCFH x 1000 continued

Capacities based on 0.6 Sp. Gr. gas at 14.7 PSIA and 60°F.

Orifice Size		3/8"	1/2"	5/8"	3/4"	1"
Inlet Pressure PSIG	Outlet Pressure PSIG	Orifice constant factor K				
		535	690	960	1175	1430
30	9 or less	11.5	14.9	20.6	25.1	30.4
	10	11.4	14.9	20.5	25.0	30.2
	15	10.9	14.2	19.6	23.8	28.8
	20	9.7	12.6	17.4	21.2	25.6
	25	7.5	9.75	13.4	16.3	19.8
40	14 or less	14.0	18.3	25.2	30.9	
	15	14.0	18.2	25.2	30.8	
	20	13.6	17.7	24.4	29.8	
	30	11.0	14.4	19.8	24.2	
50	19.5 or less	16.6	21.6	29.9	36.7	
	20	16.6	21.6	29.8	36.6	
	30	15.4	20.1	27.8	34.1	
60	24.5 or less	19.2	25.0	34.7	42.5	
	25	19.2	24.9	34.6	42.5	
	30	18.9	24.5	31.7	41.8	
75	30 or less	23.0	30.0			
100	30 or less	29.5	38.4			
125	30 or less	35.9	46.7			

K values are wide open for each orifice size.

Loading Ring set at 0° for PSIG outlet pressures. Loading ring set at 25° for inches W.C. outlet pressures. Exact settings may vary with individual pressure and load condition applications.

All capacities at 1% outlet pressure absolute pressure drop.

Set point at each outlet pressure was 500 cfh.

Maximum recommended inlet pressure - PSI to inches regulation - left of shaded area.

 Do not operate orifice in shaded inlet pressure area.

CL838 IM Capacity Table 2 x 4

Capacities based on 0.6 Sp. Gr. gas at 14.7 PSIA and 60°F.

Typical Capacity Info.		Orifice Size		3/8"	1/2"	5/8"	3/4"	1"
		Inlet Pressure PSIG	Outlet Pressure PSIG	Orifice constant factor K				
Manufacturer	Itron			535	690	980	1205	1480
Type and model	CL838 IM	2	7" w.c.	2.55	3.4	4.75	5.9	7.35
Regulator			11" w.c.	2.45	3.3	4.6	5.8	7.1
Inlet size	2-inch SCR		1	2.05	2.75	3.8	4.7	5.9
	2-inch Flanged		1.5	1.6	2.25	3.35	3.85	4.7
Outlet size	2-inch SCR 2-, 3-, 4-inch Flanged	3	7" w.c.	3.15	4.25	5.95	7.3	9.1
			11" w.c.	3.1	4.15	5.85	7.15	8.9
			1	2.8	3.75	5.25	6.5	8.05
			2	2.1	2.85	4.2	4.85	6.1
Spring color	Varies	5	7" w.c.	4.1	5.6	7.85	9.6	11.8
			11" w.c.	4.05	5.5	7.8	9.5	11.7
			1	3.9	5.3	7.45	9.0	11.1
			2	3.5	4.75	6.7	8.15	10.0
		10	3	3.0	4.05	5.7	6.9	8.55
			7" w.c.	6.05	8.0	11.2	13.6	16.8
			11" w.c.	6.0	8.0	11.1	13.6	16.7
			1	6.0	7.9	11.0	13.4	16.5
		15	2	5.8	7.75	10.7	13.1	16.1
			5	5.0	6.65	9.3	11.3	14.0
			8	3.5	4.7	6.55	7.95	9.8
			10	7.6	9.85	13.7	16.7	20.8
		20	13	4.05	5.25	7.3	8.9	11.1
			1 or less	7.6	9.85	13.7	16.7	20.8
			2	7.5	9.8	13.6	16.6	20.7
			5	7.25	9.3	13.0	15.9	19.8
		20	8	6.55	8.45	11.8	14.4	17.9
			10	5.8	7.5	10.5	12.8	15.9
			13	4.05	5.25	7.3	8.9	11.1
			3.5 or less	8.9	11.5	16.4	20.0	24.6
		20	5	8.85	11.4	16.3	19.8	24.4
			10	8.15	10.5	15.0	18.2	22.4
			15	6.4	8.25	11.8	14.3	17.6
			18	4.45	5.75	8.2	10.0	12.3

K values are wide open for each orifice size.

Figures below heavy line may show differentials above allowable limits. Check closing spring tables to confirm.

Loading Ring set at 0° for PSIG outlet pressures. Loading ring set at 25° for inches w.c. outlet pressures. Exact settings may vary with individual pressure and load condition applications.

All capacities at 1% outlet pressure absolute pressure drop.

Set point at each outlet pressure was 500 cfh.

CL838 IM Capacity Table 2 x 4 continued

Capacities based on 0.6 Sp. Gr. gas at 14.7 PSIA and 60°F.

Orifice Size		3/8"	1/2"	5/8"	3/4"	1"
Inlet Pressure PSIG	Outlet Pressure PSIG	Orifice constant factor K				
		535	690	980	1205	1480
30	9 or less	11.5	14.9	21.2	26.2	32.0
	10	11.4	14.9	21.1	26.1	31.8
	15	10.9	14.2	20.1	24.9	30.3
	20	9.7	12.6	17.9	22.1	26.9
	25	7.5	9.75	13.8	17.1	20.8
40	14 or less	14.0	18.3	25.9	32.2	
	15	14.0	18.2	25.9	32.1	
	20	13.6	17.7	25.1	31.1	
	30	11.0	14.4	20.4	25.3	
50	19.5 or less	16.6	21.6	30.7	38.1	
	20	16.6	21.6	30.6	38.0	
	30	15.4	20.1	28.5	35.4	
60	24.5 or less	19.2	25.0	35.4	44.0	
	25	19.2	24.9	35.4	44.0	
	30	18.9	24.5	34.8	43.3	
75	30 or less	23.0	30.0			
100	30 or less	29.5	38.4			
125	30 or less	35.9	46.7			

K values are wide open for each orifice size.

Figures below heavy line may show differentials above allowable limits. Check closing spring tables to confirm.

Loading Ring set at 0° for PSIG outlet pressures. Loading ring set at 25° for inches w.c. outlet pressures. Exact settings may vary with individual pressure and load condition applications.

All capacities at 1% outlet pressure absolute pressure drop.

Set point at each outlet pressure was 500 cfh.

Maximum recommended inlet pressure - PSI to inches regulation - left of shaded area.

 Do not operate orifice in shaded inlet pressure area.

CL838 IMR Performance Curves

1 PSIG Set Point¹

Regulator:	
Inlet size	2" NPT
Outlet size	4" NPT
Inlet pressure	20 PSIG
Orifice size	3/4"
Flow rate at set	500 SCFH
Spring range	Silver/white (pilots), Green closing
Set pressure	1 PSIG
Position no.	Horizontal
Bolt circle diameter	12-1/16

¹ Set point 1 PSIG with 40 PSIG inlet @ 200 SCFH. All test results are reported at a base of 14.7 PSIG at 60° F and with 0.6 S.G. gas.

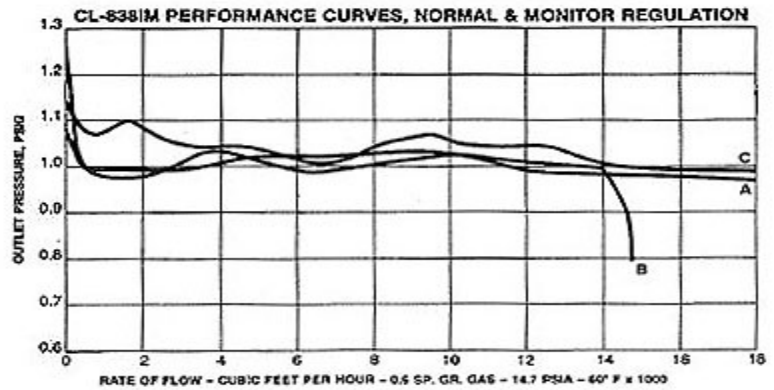

Assembly Positions

The 6 basic assembly positions are shown here.

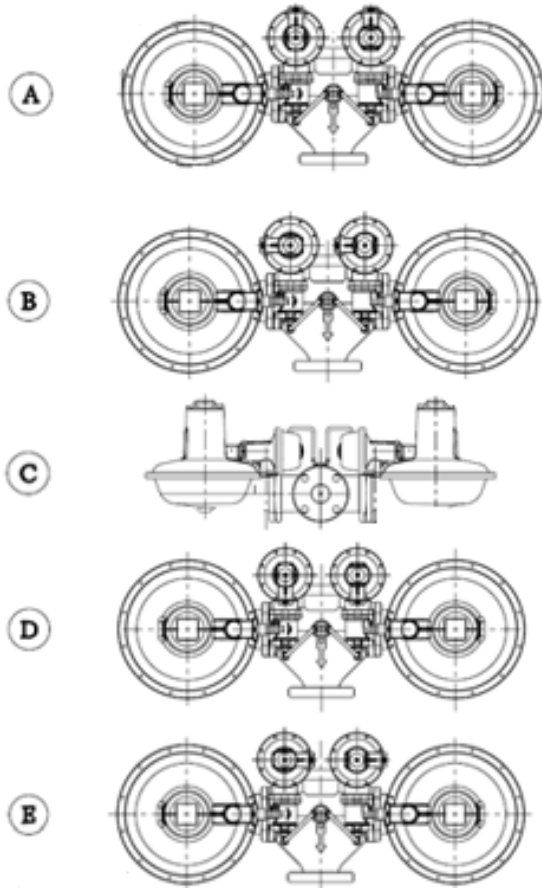

Please specify the assembly position by letter designation when ordering.

CL838M Monitor Specifications 2" x 2"

Orifice Size (inches)	Inlet Pressure PSIG	Capacity, SCFH								
		Drop in pressure across orifice, PSIG								
		0.1	0.2	0.3	0.4	0.5	1.0	2.0	3.0	5.0
1-3/8 K = 2510	1	3100	4400	5350	6200	6900				
	2	3200	4550	5550	6400	7100	9900			
	3	3300	4650	5700	6600	7350	10200	14000		
	5	3500	4950	6050	6950	7750	10800	14900	17700	
	8	3750	5300	6500	7450	8350	11600	16100	19200	23600
	10	3900	5550	6750	7800	8700	12200	16900	20200	24900
	15	4300	6050	7450	8550	9550	13400	18600	22400	27800
	25	4950	7050	8600	9950	11100	15600	21700	26300	33000
	35	5550	7850	9650	11100	12400	17500	24500	29700	37500
	50	6350	9000	11000	12700	14200	20000	28100	34100	43300
75	7500	10600	12900	15000	16700	23600	33200	40400	51600	
1-1/4 K = 2280	1	2800	4000	4900	5600	6250				
	2	2900	4100	5050	5800	6450	9000			
	3	3000	4250	5200	5950	6650	9300	12700		
	5	3150	4500	5500	6300	7050	9850	13500	16100	
	8	3400	4800	5900	6800	7550	10600	14600	17500	21400
	10	3550	5000	6150	7100	7900	11000	15300	18300	22600
	15	3900	5500	6750	7800	8700	12200	16900	20400	25300
	25	4500	6400	7800	9000	10000	14100	19700	23900	30000
	35	5050	7150	8750	10100	11300	15900	22200	26900	34000
	50	5750	8150	1000	11500	12900	18100	25500	31000	39300
75	6800	9600	11800	13600	15200	21400	30100	36700	46900	
1 K = 1850	1	2300	3250	3950	4550	5100				
	2	2350	3350	4100	4700	5250	7300			
	3	2450	3450	4200	4850	5400	7550	10300		
	5	2550	3650	4450	5100	5700	8000	11000	13000	
	8	2750	3900	4750	5500	6150	8600	11900	14200	17400
	10	2900	4050	5000	5750	6400	9000	12400	14900	18300
	15	3150	4450	5450	6300	7050	9900	13700	16500	20500
	25	3650	5150	6350	7300	8150	11500	16000	19400	24300
	35	4100	5800	7100	8200	9150	12900	18000	21800	27600
	50	4700	6600	8100	9350	10400	14700	20700	25100	31900
	75	5500	7500	9550	11000	12300	17400	24500	29800	38000
100	6250	8850	10800	12500	13900	19700	27700	33800	43300	

CL838 Monitor Specifications 2" x 3"

Orifice Size (inches)	Inlet Pressure PSIG	Capacity, SCFH								
		Drop in pressure across orifice, PSIG								
		0.1	0.2	0.3	0.4	0.5	1.0	2.0	3.0	5.0
1-3/8 K = 2710	1	3350	4750	5800	6700	7450				
	2	3450	4900	6000	6900	7700	10700			
	3	3550	5050	6150	7100	7900	11000	15100		
	5	3750	5350	6500	7500	8350	11700	16100	19100	
	8	4050	5700	7000	8050	9000	12600	17400	20800	25400
	10	4250	5950	7300	8400	9400	13100	18200	21800	26800
	15	4650	6550	8000	9250	10300	14500	20100	24200	30100
	25	5350	7600	9300	10700	11900	16800	23500	28400	35600
	35	6000	8500	10400	12000	13400	18900	26400	32000	40500
	50	6850	9700	11900	13700	15300	21600	30300	36800	46800
75	8100	11400	14000	16100	18000	25500	35800	43700	55700	
1-1/4 K = 2515	1	3100	4400	5400	6200	6900				
	2	3200	4550	5550	6400	7150	9950			
	3	3300	4700	5700	6600	7350	10200	14000		
	5	3500	4950	6050	6950	7750	10800	14900	17800	
	8	3750	5300	6500	7500	8350	11700	16100	19300	23600
	10	3900	5550	6800	7800	8700	12200	16900	20200	24900
	15	4300	6100	7450	8600	9600	13400	18700	22500	27900
	25	5000	7050	8600	9950	11100	15600	21800	26300	33100
	35	5600	7900	9650	11100	12400	17500	24600	29700	37500
	50	6350	9000	11000	12700	14200	20000	28100	34200	43400
75	7500	10600	13000	15000	16700	23600	33300	40500	51700	
1 K = 2075	1	2550	3650	4450	5100	5700				
	2	2650	3750	4600	5250	5900	8200			
	3	2750	3850	4700	5450	6050	8450	11600		
	5	2900	4050	5000	5750	6400	8950	12300	14600	
	8	3150	4400	5350	6150	6900	9650	13300	15900	19500
	10	3250	4550	5600	6450	7200	10100	13900	16700	20500
	15	3550	5000	6150	7100	7900	11100	15400	18500	23000
	25	4100	5800	7100	8200	9150	12900	18000	21700	27300
	35	4600	6500	7950	9200	10200	14400	20200	24500	31000
	50	5250	7450	9100	10500	11700	16500	23200	28200	35800
	75	6200	8750	10700	12400	13800	19500	27400	33400	42700
100	7000	9900	12100	14000	15600	23500	31100	37900	49500	

CL838 Monitor Specifications 2" x 4"

Orifice Size (inches)	Inlet Pressure PSIG	Capacity, SCFH								
		Drop in pressure across orifice, PSIG								
		0.1	0.2	0.3	0.4	0.5	1.0	2.0	3.0	5.0
1-3/8 K = 3050	1	3800	5350	6550	7500	8400				
	2	3900	5500	6750	7750	8650	12000			
	3	4000	5700	6950	8000	8900	12400	17000		
	5	4250	6000	7350	8450	9450	13100	18100	21500	
	8	4550	6450	7900	9100	10100	14200	19600	23400	28600
	10	4750	6750	8250	9500	10600	14800	20500	24600	30200
	15	5200	7400	9050	10400	11600	16300	22700	27200	33800
	25	6050	8550	10400	12000	13500	18900	26400	32000	40100
	35	6750	9550	11700	13500	15100	21200	29700	36100	45500
	50	7750	10900	13400	15400	17200	24300	34100	41400	52600
75	9100	12900	15700	18200	20300	28700	40300	49100	62700	
1-1/4 K = 2625	1	3250	4600	5600	6450	7200				
	2	3350	4750	5800	6700	7450	10400			
	3	3450	4900	5950	6900	7650	10700	14700		
	5	3650	5150	6300	7250	8100	11300	15600	18500	
	8	3900	5550	6800	7800	8700	12200	16800	20100	24600
	10	4100	5800	7100	8150	9100	12700	17600	21100	26000
	15	4500	6350	7750	8950	10000	14000	19500	23400	29100
	25	5200	7350	9000	10400	11600	16300	22700	27500	34500
	35	5800	8250	10100	11600	13000	18300	25600	31000	39200
	50	6650	9400	11500	13300	14800	20900	29300	35700	45300
75	7850	11100	13500	15600	17500	24700	34700	42300	54000	
1 K = 2190	1	2700	3850	4700	5400	6000				
	2	2800	3950	4850	5550	6200	8650			
	3	2900	4050	5000	5750	6400	8900	12200		
	5	3050	4300	5250	6050	6750	9450	13000	15900	
	8	3250	4600	5650	6500	7250	10200	14000	16800	20600
	10	3400	4800	5900	6800	7600	10600	14700	17600	21700
	15	3750	5300	6500	7450	8350	11700	16300	19600	24300
	25	4350	6150	7500	8650	9650	13600	19000	22900	28800
	35	4850	6850	8400	9700	10800	15200	21300	25900	32700
	50	5550	7850	9600	11100	12400	17400	24500	29700	37800
75	6550	9250	11300	13000	14600	20600	29000	35300	45000	
100	7400	10400	12800	14800	16500	23300	32800	40000	51200	

Parts List

CL838 Twin Parallel Flow Regulator

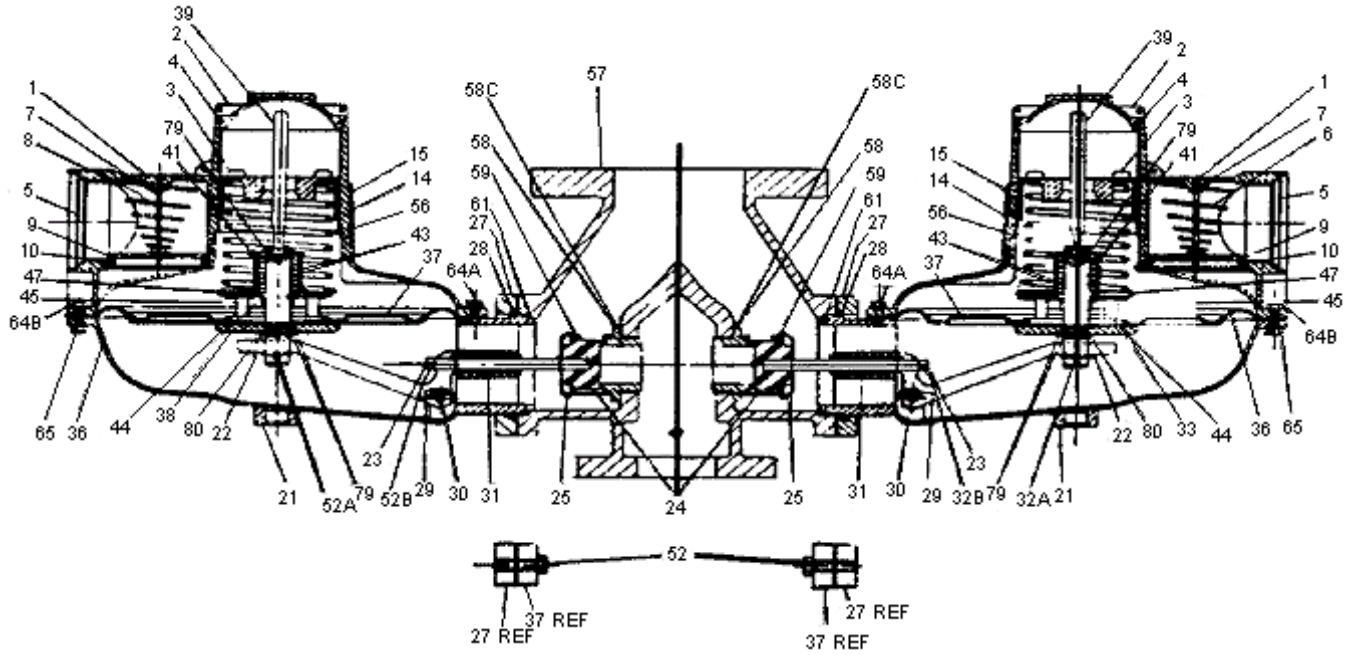

CL838 IM Twin Parallel Flow Regulator

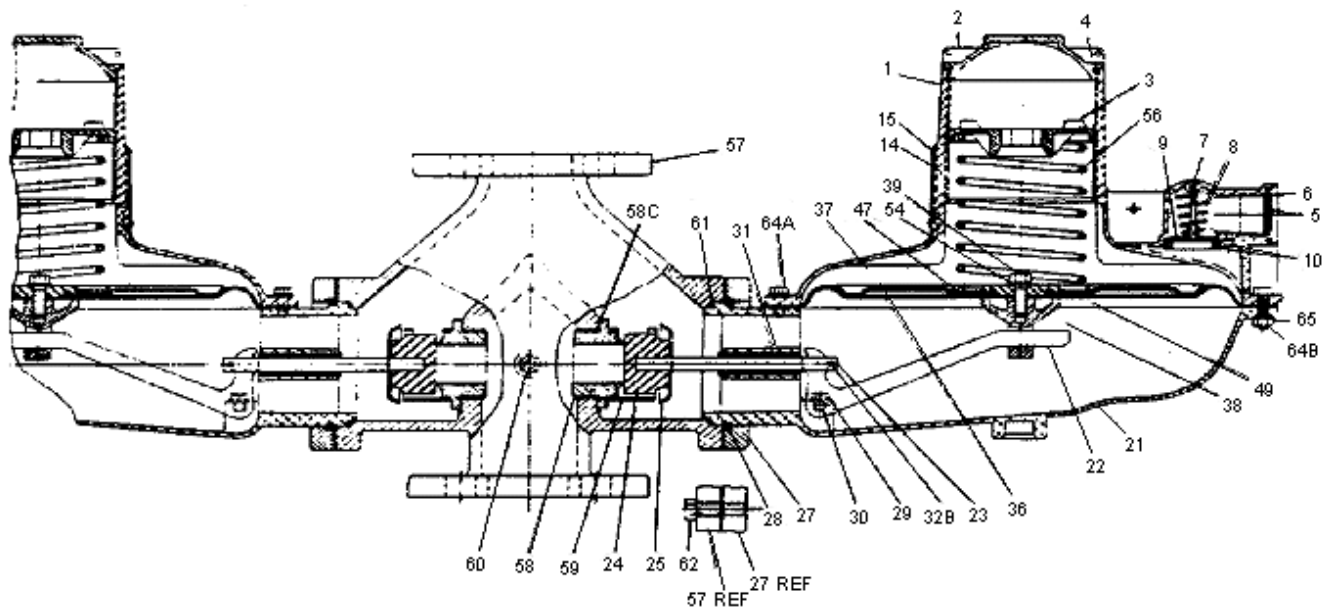

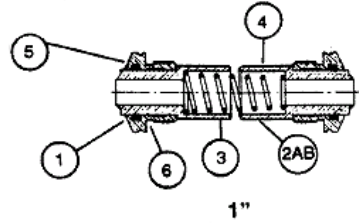
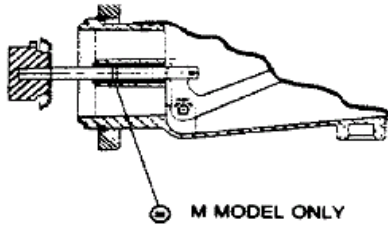

Item Number	Part Number	Quantity Required per Regulator Model						Description
		RD	RM	D	M	R	N	
1	753404	-	-	2	2	-	2	Upper diaphragm case – vent – 1" pipe
1A	753434	2	2	-	-	2	-	Upper diaphragm case – vent – 2-1/2" pipe
2	760083	2	2	2	2	2	2	Seal cap
3	760233	-	-	2	2	-	2	Adjustment screw
3A	760253							Adjustment screw
4	765607							Seal cap gasket
5	762933							Vent screen – 1" vent
5A	762941							Vent screen – 2-1/2" vent
6	75579101							Vent screen retainer ring – 1" vent
7	75483401							Vent valve disc pin - 1" vent
7A	754801							Vent valve disc pin – 2-1/2" vent
8	762601							Vent valve spring – 1" vent
8A	80000601							Vent valve spring – 2-1/2" vent
9	765181							Vent valve disc - 1" vent
9A	765343							Vent valve disc – 2-1/2"
10	765685							Vent valve seat – 1" vent
10A	761651							Vent valve seat – 2-1/2" vent
14	769241							Regulator badge
	769245							Regulator badge - IM
15	755071							Badge drive screw
21								Lower diaphragm case
	715065							4:1 ratio - open throat
	715066							3.5:1 ratio – closed throat
22								Valve linkage lever
	761275							4:1 ratio standard
	761271							3.5:1 ratio
23								Valve stem
	754191							3/8" square
	754193							17/32" diamond without ring groove

Item Number	Part Number	Quantity Required per Regulator Model						Description
		RD	RM	D	M	R	N	
24	765211							Valve seal -Buna N – 80 Durometer
25	761731							Deflector
27	751933							Valve body retainer plate
28	755721							Retainer - snap ring
29	755223							Valve linkage pin screw
30	754836							Valve linkage pin
33	765505							Valve stem O-ring
36	766321							Diaphragm – relief
	766301							Diaphragm – no relief
37	761091							Upper diaphragm plate
	76104101							Upper diaphragm plate
38								Lower diaphragm plate
	756075							No bead
	756081							With bead
39	755363							Stop Stem
	754385							Stop stem sub - assembly - self aligning
	754381							Lower
	754383							Upper
	755739							Retaining ring (lower stem)
	765171							Disc (rubber)
41	761455							Relief spring guide
43	762401							Relief spring brown - standard
	762403							Relief spring - green
44	754941							Stop stem guide bushing
45	761671							Relief cap
47	761481							Adjustment spring guide
	761483							Adjustment spring guide
	755001							Roll pin - stop stem
	755007							3/32 diameter x 3/8 length
	755009							3/32 diameter x 1/2 length
54	755851							Diaphragm plate washer - lock

Item Number	Part Number	Quantity Required per Regulator Model						Description
		RD	RM	D	M	R	N	
56		2	2	2	2	2	2	Adjustment spring - specify
	762351							Brown
	762353							Green
	762355							Black
	762357							Blue
	762358							Blue/White
	762359							Silver
	762361							Yellow
	762671							Red (nested)
	762673							White (nested)
	762321							Green/White stripe
	762323							Silver/Red
	762341							Orange
	762345							Orange/Green
	762365							Purple
57		1	1	1	1	1	1	Valve body - specify type and size:
								Straight
	750954							2 X 2 NPT
	750959							2 x 2 NPT with 1/8" NPT pipe plug
57								Flanged
	750965							2 x 2" ASA 10" face to face
	750969							2 x 2" ASA with 1/8 NPT pipe plug
	750974							2 x 3" ASA 10" face to face
	750975							2 x 3" ASA with 1/8 NPT pipe plug
	750984							2 x 4" ASA 10" face to face
	750985							2 x 4" ASA with 1/8 NPT pipe plug
	750989							2 x 4" ASA with 1/4 NPT outlet tap

Item Number	Part Number	Quantity Required per Regulator Model						Description
		RD	RM	D	M	R	N	
58		2	2	2	2	2	2	Orifice - specify type and size: Straight - Brass - 2'A" II ext
	758371							.320 X 3/8
	758372							1/4 X 3/8
	758398							1/4
	758401							1/2
	758404							3/4
	758407							1", B38/838 CL38/838"
	758410							1-1/4
	758413							1-3/8
	758416							5/8
	758419							3/8
								IM Orifice Assemblies – See Internal Monitor Orifice Assembly Parts Lists
59	761771	2	2	2	2	2	2	Loading ring
60								Valve body pipe plug
	768443	See item #57 for required quantity						1/8 NPT - steel
	764431							1/8 NPT - stainless steel
61	80001901	2	2	2	2	2	2	Valve body gasket
62	755391	4	4	4	4	4	4	Retainer plate screw - 3/8 - 16 X 1 - 5/16 hex head
62A	755393	4	4	4	4	4	4	Retainer plate screw 3/8 16 X 1 5/16 hex head - drilled head for wire seal
64B	755307	24	24	24	24	24	24	Case screw - hex head - 1 20 x 1" length steel
65	755513	20	20	20	20	20	20	Case screw nut
79	755711	6	6	-	-	6	-	Stop stem retainer ring - external
80	766521	2	2	-	-	2	-	O-ring lower diaphragm
91	765525	2	2	2	2	2	2	Orifice O-ring

Item Number	Part Number	Quantity Required per Regulator Model						Description
		RD	RM	D	M	R	N	
Subassemblies								
	710040	-	-	2	2	-	2	Upper diaphragm case - 1" vent,
	715030	-	-	-	-	2	2	Lower diaphragm case subassembly
								Lower diaphragm case subassembly 3:5:1 ratio - closed throat
	715031	-	2	-	2	-	-	With valve stem O-ring
	715064	2	-	2	-	-	-	Without valve stem O-ring
	720029	-	-	2	2	-	2	Diaphragm subassembly - no relief
	720033	2	2	-	-	2	-	Diaphragm subassembly - relief – standard
	720034	2	2	-	-	2	-	Diaphragm subassembly - relief – green relief spring

Special Tools

Description	Part No.
Machined orifice wrench	799027
Seal wire, no lead, 24	80002002

Notes:

- CL838 IMN parts are identical to CL838N parts except for the orifice assembly.
- CL838 IMR parts are identical to CL838R parts except for the orifice assembly.
- CL838 IMRV parts are identical to CL838R parts except for the orifice assembly.

Torque Specifications

Retainer Plate Screws	100 in. lbs.
Orifice	600 in. lbs.
Orifice (IM)	300 in. lbs.
Margin screws (item no.648)	50 in. lbs.
Margin screws (item no. 64A)	30 in. lbs.

CL838-1 Pilot Parts List

(see main parts list for pilot assembly part numbers)

Item No.	Part No.	Quantity	Description
		CL838-1 RI	
1	753027	1	Upper diaphragm case – 3/4" vent
2	760053	1	Seal cap
3	760217	1	Adjustment screw - aluminum
4	765771	1	Seal cap gasket
5	762935	1	Vent screen - wire mesh
6	75572701	1	Vent screen retaining ring
7	754806	1	Vent screen disc pin
8	762601	1	Vent valve spring
9	765181	1	Vent valve disc
10	765685	1	Vent valve seat
21	752014	1	Lower diaphragm case
22	761201		Valve linkage lever

Item Number	Part Number	Quantity	Description
		CL-838-RI	
23	754021	1	Valve stem - aluminum
24	765021	1	Valve seat - Buna "N" - 75 Duro
27	751913	1	Valve body retainer plate
28	755725	1	Retainer plate snap ring
29	755141	2	Valve linkage pin screw
30	754831	1	Valve linkage pin
38	766010	1	Diaphragm
37	761001	1	Upper diaphragm plate
38	756021	1	Lower diaphragm plate
41	761401	1	Relief spring guide
43	762051	1	Relief spring 7" w.c. above set
44	754905	1	Stop stem guide bushing
50	765755	1	Relief valve seal gasket
		1	CL838-1 pilot – please specify
71A	700100-1		green/white
71A	700100-2		blue/white
71A	700100-3		dark green
71A	700100-4		silver/white
71A	700100-5		yellow/white
71A	700100-6		red/white
71A	700100-7		Pilot white
71A	700100-8		Pilot silver (B31)
			CL838-2 pilot – please specify
71B	700200-1		brown
71B	700200-12		Green adjust/green relief
71B	700200-2		green
71B	700200-3		black
71B	700200-4		blue
71B	700200-5		silver
71B	700200-6		green/white
56		1	Adjustment spring - specify:
	762007		Green/white
	762013		Blue/white
	762117		Dark green
	762017		Silver/white
	762021		Yellow/white
	762027		Red/white
	762029		White
	762034		Yellow/blue
	762650		Yellow/black
57	750044	1	90° Valve body 3/4" x 1"
58	757255	1	Orifice - 1/8" diameter - brass
59	761753	1	Loading ring
61	765751	1	Valve body gasket - flat
62	755371	2	Retainer plate screw - hex-head steel – 5/16" - 18 x 1-1/8" length, cad. plate
64	755221	8	Case screw - hex washer head steel #8-32 x 13/16" length, cad. plate

CL838-2 Pilot Parts List

(see main parts list for pilot assembly part numbers)

Item No.	Part No.	Quantity	Description
1	753044	1	Upper diaphragm case – 3/4" vent
2	730003	1	Seal cap assembly
3	760201	1	Adjustment screw
4	765603	1	Seal cap gasket
5	762905	1	Vent screen - spiral
6	75572701	1	Vent screen retaining ring
19	730101	1	Vent valve assembly
21	752311	1	Lower diaphragm case
22	761201	1	Valve linkage lever
23	754021	1	Valve stem
24	765021	1	Valve Seat - Buna "N" - 75 Duro
27	751955	1	Valve body retainer plate
28	755725	1	Retainer plate snap ring
29	755141	2	Valve linkage pin screw
30	754832	1	Valve linkage pin
36	766031	1	Diaphragm
37	761011	1	Upper diaphragm plate
38	756001	1	Lower diaphragm plate
39	755191	1	Stop stem - steel
41	761411	1	Relief spring guide
43	762081	1	Relief spring - brown 1.5 PSIG above set
47	761421	1	Adjustment spring guide
50	765711	1	Relief valve seal gasket
51	756005	1	Diaphragm plate screw
52	755001	1	Roll pin
56		1	Adjustment spring - specify
	762401		Brown
	762403		Green
	762405		Black
	762407		Blue
	762409		Silver
57	750044	1	90° Valve body 3/4" x 1"
58	757255	1	Orifice 1/8" diameter - brass
59	761753	1	Loading ring
61	765753	1	Valve body gasket
62	755371	2	Retainer plate screw hex head steel 5/16 -18 x 1-1/8" length cad. plate
64	755175	8	Case screw - soc. head #10 - 24 x 7/8" length steel cad. plate
66	755855	8	Lock washer
67	755821	1	Washer, anti-friction

Vent Lines for Regulators

When constructing vent lines to attach to regulators installed indoors, follow a few basic rules:

- a. Never use pipe sizes smaller than the vent size; smaller pipe sizes restrict the gas flow. If a long gas run must be used, Itron advises increasing the pipe one nominal size every ten feet to keep the flow restriction as low as possible.
- b. Keep the vent line length as short as possible to minimize the restriction and reduce the vent's tendency to cause regulator pulsation.
- c. Support the vent pipe to eliminate strain on the regulator diaphragm case.
- d. Always point outdoor vent pipes in the downward position to reduce the possibility of rain, snow, sleet, and other moisture entering the pipe. Install a bug screen in the end of the pipe.
- e. Do not locate the vent line terminus near windows, fans, or other ventilation equipment. See the installation instructions furnished with the regulator.
- f. Adhere to all applicable codes and regulations.
- g. If your vent pipe causes regulator pulsation, consult your sales representative or manufacturer.
- h. Itron strongly recommends running a separate vent line for each regulator. Headers with various installed devices can cause regulator malfunction.

Caution Ensure the end of the vent line is away from ANY potential ignition sources. It is the installer's responsibility to ensure the vent line is exhausting to a safe environment.

Installation

Warning Itron does not endorse or warrant the completeness or accuracy of any third party regulator installation procedures or practices, unless otherwise provided in writing by Itron. Follow your company's standard operating procedures regarding the use of personal protection equipment (PPE). Adhere to guidelines issued by your company in addition to those given in this document when installing regulators.

- a. Remove all shipping plugs from the regulator inlet, outlet, and vent before installation.
- b. Verify the piping interior and regulator inlet and outlet are clean and free of dirt, pipe dope, and other debris. Dirt and other foreign materials entering the regulator can cause a loss of pressure control.
- c. Apply pipe joint sealant to the male pipe threads. Do not use pipe joint material on the regulator's female threads. Joint sealant could become lodged in the regulator and cause a loss of pressure control.
- d. Gas must flow through the regulator's valve body in the direction cast on the regulator body. Gas flowing in the wrong direction can overpressure and cause damage to the regulator.
- e. The pilot diaphragm casing can be mounted in any position relative to the body through a full 360° angle at 90° increments.
- f. When the regulator is installed OUTDOORS, the vent must always be positioned so that rain, snow, moisture or foreign particles cannot enter the vent opening. Itron recommends positioning the pilot vent downward to avoid entry of water or other matter which could interfere with the proper operation of the regulator. The vent should be located away from building eaves, window openings, building air intakes and above the expected snow level at the site. The vent opening should be inspected periodically to insure it does not become blocked by foreign material as outlined in DOT PHMSA-RSPA-2004-19856.
- g. When the regulator is installed INDOORS, the vent must be piped to the outside atmosphere using the shortest length of pipe, the fewest possible pipe elbows, and a pipe diameter as large as the vent size or larger. USING VENT PIPE SMALLER THAN THE VENT CONNECTION LIMITS THE REGULATOR'S INTERNAL RELIEF VALVE CAPACITY. The outlet end of the pipe must be protected from moisture and the entrance of foreign particles. The regulator should be specified by the user with the size vent and pipe threads desired to make the vent pipe connection.

Startup Procedure

- a. Mount a pressure gauge downstream of the regulator to monitor the downstream pressure.
- b. With the downstream pressure valve closed, slowly open the inlet valve. The outlet pressure should rise to slightly more than the set-point. Verify there are no leaks and all connections are tight.
- c. The regulator was pre-set at the factory to match order specifications. If necessary, adjust the outlet pressure by removing the seal cap on the top of the pilot spring housing and adjusting the ferrule or screw inside the pilot spring housing using a large flat-head screwdriver. With a small amount of gas flowing through the regulator, rotate the pilot ferrule clockwise to raise the outlet pressure or counter-clockwise to lower the outlet pressure.
- d. Replace the seal cap and check for leaks after the desired outlet pressure is achieved.

The regulator is ready for operation.

Safety Warning

This product, as of the date of manufacture, is designed and tested to conform to all governmental and industry safety standards as they may apply to the manufacturer. The purchaser/user of this product must comply with all fire control, building codes, and other safety regulations governing the application, installation, operation, and general use of this regulator to avoid leaking gas hazards resulting from improper installation, startup or use of this product.

Itron strongly recommends installation by a qualified professional and periodic inspection of pressure regulators (inspections may be required by local applicable codes or regulations).

Inspections should include checking for gas quality, cycle numbers, external environmental changes, and operating conditions that impact wear on the regulator's moving parts. To ensure safe and efficient operation of this product, replace worn or damaged parts found during inspection.

Limited Warranty

Itron, Inc. 970 Highway 127 North, Owenton, Kentucky 40359-9302, warrants this gas product against defects in materials and workmanship for the earlier of one (1) year from the date the product is shipped by Itron or a period of one year from the date the product is installed by Itron at the original purchaser's site. During such one-year period, provided that the original purchaser continues to own the product, Itron will, at its sole option, repair any defects, replace the product or repay the purchase price.

- > This warranty will be void if the purchaser fails to observe the procedures for installation, operation or service of the product as set forth in the Operating Manual and Specifications for the product or if the defect is caused by tampering, physical abuse or misuse of the product.
- > ITRON SPECIFICALLY DISCLAIMS ALL IMPLIED WARRANTIES INCLUDING THOSE OF MERCHANTABILITY OR OF FITNESS FOR A PARTICULAR PURPOSE. UNDER NO CIRCUMSTANCES WILL ITRON BE LIABLE FOR INCIDENTAL OR CONSEQUENTIAL DAMAGES OF ANY KIND WHATSOEVER.
- > Itron's liability for any claim of any kind, including negligence and breach of warranty for the sale and use of any product covered by or furnished, shall in no case exceed the price allocable to the product or part thereof which gives rise to the claim.

- > In the event of a malfunction of the product, consult your Itron Service Representative or Itron Inc., 970 Highway 127 North, Owenton, Kentucky 40359-9302. See Itron Terms and Conditions of Sale for the full and complete terms of the Limited Warranty.

Ordering Information

Specify:

1. Inlet and Outlet Connection Size and Type
2. Model Number
3. Outlet pressure desired
4. Pilot needed
5. Inlet pressure range
6. Type of gas and maximum capacity required
7. Assembly position number (see chart below)
8. Special requirements such as tagging, 1/8" pipe plug tap, seal wire, etc.

About Itron Inc.

At Itron, we're dedicated to delivering end-to-end smart grid and smart distribution solutions to electric, gas and water utilities around the globe. Our company is the world's leading provider of smart metering, data collection and utility software systems, with nearly 8,000 utilities worldwide relying on our technology to optimize the delivery and use of energy and water. Our offerings include electricity, gas, water and heat meters; network communication technology; collection systems and related software applications; and professional services. To realize your smarter energy and water future, start here: www.itron.com



Itron Gas

970 Highway 127 North
Owenton, Kentucky 40359
USA
Phone: 1.800.490.0657
1.502.484.5747
fax: 1.502.484.6223

Corporate Headquarters

2111 North Molter Road
Liberty Lake, WA 99019
USA
Phone: 1.800.635.5461
Fax: 1.509.891.3355
www.itron.com