

CL231 Series Regulator

Commercial Regulator

Applications

The CL231 regulator is designed primarily for use in medium size commercial and industrial installations requiring highly accurate pressure regulation. The CL231 can produce substantial savings for users in lower initial costs, lower installation costs, and lower maintenance costs.

The CL231 was designed for systems requiring highly accurate pressure regulation such as:

- > Metering loads (approx. 500 to 7500 CFH) without the need for expensive instrumentation.
- > As a 1 ½" or 2" regulator covering the outlet range from 1 PSIG to 20 PSIG without downstream control.
- > Where very accurate PSI to PSI regulation ($\pm 1\%$ outlet pressure absolute) is desired than is obtainable from conventional spring loaded regulators ahead of a "Fixed Factor Billing" meter or ahead of a "Pressure Compensating Index" meter.
- > As a reliable and accurate replacement (without downstream control) for conventional regulators requiring downstream control.

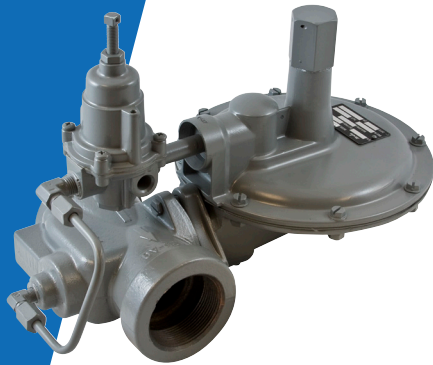

Features

- > Internal bleed to prevent vapor lock-up
- > Internal lower diaphragm chamber pressure flow control
- > Wide range of set points available with minimum number of springs
- > Compact regulator able to provide flow rates up to 7500 CFH

Description

- > CL231R – The CL231R is a constant pressure loaded regulator equipped with a pilot internal relief valve. The pilot relief valve is not designed for "full capacity" relief, but rather to limit the loading chamber pressure to a safe value in the event of failure.
- > CL231N – The CL231N is a constant pressure loaded regulator that utilizes a pilot with no internal relief (N). This regulator can be used where PSIG to PSIG regulation is required with no internal relief.

Shipping weight per box

Four regulators Box weight: 53 lbs.

CL231 Dimensions (inches)

| Valve Body | A | B | C | D | E |
|------------------------|-------|-------|---|-------|---|
| NPT (all sizes) | 5-3/4 | 2-7/8 | 8 | 6-1/2 | 2 |
| Flanged (all sizes) | 10 | 5 | | | |

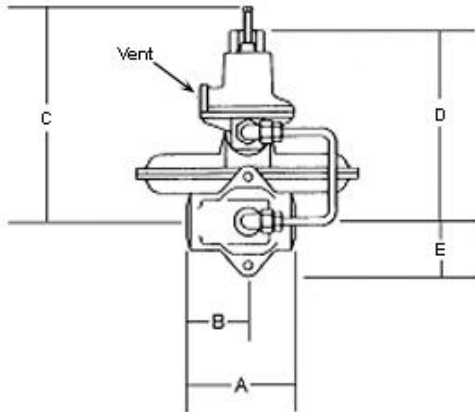

Operational Schematic

Shown with N-type pilot.

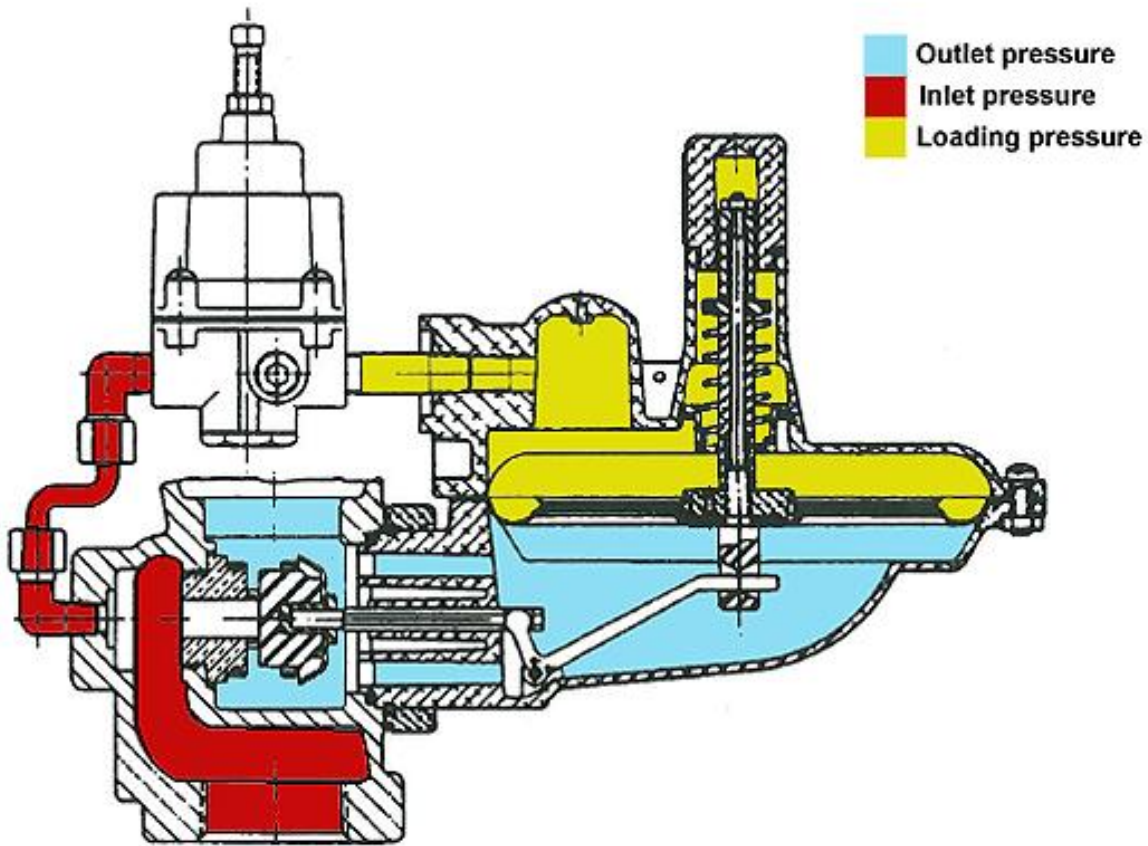

Note: Valve shown in closed position.

Spring Data - Spring Color Outlet Pressure Range*

| Model R* | (PSIG) |
|----------|-------------|
| Orange | 1.0 to 1.6 |
| Brown | 1.6 to 2.6 |
| Green | 3.5 to 7.4 |
| Black | 3.8 to 13.3 |
| Blue | 4.6 to 21.5 |
| Model N* | |
| Blue | 1.0 to 20 |

*Warning: Pilot springs are not interchangeable between N and R pilots.

Orifice Data - Wide Open Flow Coefficients and Maximum Pressures

| Orifice Size (inches) | K-Factor | Maximum Operating Inlet Pressure (PSIG) | Maximum Emergency Inlet Pressure (PSIG) | Maximum Emergency Outlet Pressure (PSIG) |
|-----------------------|----------|---|---|--|
| 1/4 | 125 | 125 | 175 | 60 |
| 3/8 | 290 | 75 | 100 | |
| 1/2 | 500 | 50 | 75 | |

Operating Temperature Range

- -20°F to 150°F
- Silicone valve seats available for applications below -20°F

Additional Specifications

| | |
|-----------------------------------|--|
| Available pilot vent sizes | 1/4-inch NPT |
| Loading ring position | For inlet pressure < 15 PSIG: 12° For inlet pressure > 15 PSIG: 15° |
| Closing spring (non-adj.) | Light green only |
| Other available options | Seal wire to indicate unapproved tampering 1/8" pipe plug tap on upstream side of valve body Pilot supply line filter (contact Itron, Owenton, KY) Stainless steel supply line fittings Teflon valve body gasket |

Itron takes pride in delivering American made products with the utmost concern for safety, quality, and customer satisfaction.

Construction materials:

| | |
|-----------------------|---|
| Closing spring | Music wire |
| Valve body | High tensile strength cast iron (ASTM A-126, Class A) |
| Orifice | Brass (ASTM B16, Alloy 360), aluminum - optional |
| Valve seat | Buna-N or silicone (for temperatures below -20°F) |
| Valve stem | Plated steel (Aluminum alloy 2011-T3) |
| Lever pin | Stainless steel (Type 303) |
| Lever | Zinc and dichromate plated steel (AISI C1010) |
| Upper diaphragm plate | Zinc and dichromate plated steel (14 gauge steel) |
| Lower diaphragm plate | Die cast aluminum (ASTM B-85 Alloy SC84A) |
| Diaphragm | Buna-N and nylon |
| Pilot vent screen | Stainless steel (16 mesh) |
| Adjustment ferrule | Die cast aluminum (ASTM CS43A) |
| Seal cap | Die cast aluminum (ASTM CS43A) |
| Diaphragm case | Die cast aluminum (ASTM B85-Alloy SC84A) |

Valve Body Sizes (inches)

| Inlet | Outlet | Screwed (NPT-thread) | Flanged (ASA 125) |
|-------|--------|----------------------|-------------------|
| 1-1/4 | 1-1/4 | X | |
| 1-1/4 | 1-1/2 | X | |
| 1-1/4 | 2 | X | |
| 1-1/2 | 1-1/2 | X | |
| 1-1/2 | 2 | X | |
| 2 | 2 | X | X |
| 3 | 3 | | X |

X indicates the valve body is available in that configuration.

Correction factors for non-natural gas applications

The CL231 may be used to control gases other than natural gas. To determine the capacity for gases other than natural gas, multiply the values within the capacity tables by a correction factor. The table below lists the correction factors for some of the more common gases:

| Gas Type | Specific Gravity | Correction Factor (CF) |
|-----------------------|------------------|------------------------|
| Air | 1.00 | 0.77 |
| Butane | 2.01 | 0.55 |
| Carbon Dioxide (Dry) | 1.52 | 0.63 |
| Carbon Monoxide (Dry) | 0.97 | 0.79 |
| Natural Gas | 0.60 | 1.00 |
| Nitrogen | 0.97 | 0.79 |
| Propane | 1.53 | 0.63 |
| Propane-Air-Mix | 1.20 | 0.71 |

To calculate the correction factor for gases not listed in the table above, use the gases' specific gravity and insert it in the formula listed below:

$$\text{Correction Factor (CF)} = \sqrt{\frac{SG_1}{SG_2}}$$

Where:

SG_1 = Specific gravity of the gas in which the capacity is published.

SG_2 = Specific gravity of the gas to be controlled.

Wide Open Flow Calculations

For wide-open orifice flow calculations use the following equations:

$$\text{For } P_1/P_2 < 1.89 \text{ use: } Q = K\sqrt{P_2(P_1 - P_2)}$$

$$\text{For } P_1/P_2 > 1.89 \text{ use: } Q = \frac{KP_1}{2}$$

Where: P_1 = Absolute Inlet Pressure (PSIA)

P_2 = Absolute Outlet Pressure (PSIA)

Q = Flow Rate (scfh)

K = Orifice Coefficient (scfh/PSI)

CL231 Capacity Table (Models R and N)*

1% Absolute Droop

Capacities in SCFH of 0.6 S.G. gas; base conditions of 14.7 PSIA and 60°F.

Typical Capacity Info.

| | |
|------------------------|--------|
| Manufacturer | Itron |
| Type and model: | CL231 |
| Regulator | |
| Inlet size: | 2" NPT |
| Outlet size: | 2" NPT |
| Spring color: | Varies |
| Position | 5 |

| | | Orifice Size | | |
|-----------------------|------------------------|--------------|------|------|
| Inlet Pressure (PSIG) | Outlet Pressure (PSIG) | 1/4" | 3/8" | 1/2" |
| 2 | 1 | 475 | 675 | 1100 |
| 3 | 1 | 675 | 1050 | 1750 |
| | 2 | 475 | 750 | 1250 |
| 5 | 1 | 940 | 1650 | 2600 |
| | 2 | 800 | 1550 | 2300 |
| 10 | 1 | 1440 | 2700 | 4350 |
| | 2 | 1400 | 2700 | 4200 |
| | 5 | 1150 | 2100 | 3000 |
| 15 | 1 | 1850 | 3550 | 5950 |
| | 2 | 1850 | 3550 | 5950 |
| | 5 | 1750 | 3200 | 5200 |
| | 10 | 1100 | 2100 | 2950 |
| 20 | 1 | 2200 | 4300 | 7250 |
| | 2 | 2200 | 4300 | 7250 |
| | 5 | 2100 | 4100 | 6700 |
| | 10 | 1850 | 3450 | 5700 |
| | 15 | 1100 | 1650 | 2600 |
| 30 | 1 | 2800 | 5800 | 7500 |
| | 2 | 2800 | 5800 | 7500 |
| | 5 | 2800 | 5800 | 7500 |
| | 10 | 2700 | 5350 | 7500 |
| | 15 | 2350 | 4350 | 7450 |
| | 20 | 2100 | 3600 | 6300 |
| 40 | 1 | 3500 | 7100 | 7500 |
| | 2 | 3500 | 7100 | 7500 |
| | 5 | 3500 | 7100 | 7500 |
| | 10 | 3500 | 7100 | 7500 |
| | 15 | 3300 | 6100 | 7500 |
| | 20 | 3200 | 6000 | 7500 |
| 50 | 1 | 4100 | 7500 | 7500 |
| | 2 | 4100 | 7500 | 7500 |
| | 5 | 4100 | 7500 | 7500 |
| | 10 | 4100 | 7500 | 7500 |
| | 15 | 4100 | 7500 | 7500 |
| | 20 | 3500 | 7500 | 7500 |

Notes:

3/4-inch outlet pipe size limits the capacity to 2000 SCFH.

1-inch outlet pipe size limits to 3000 SCFH.

*Individual regulator performance may vary from data shown.

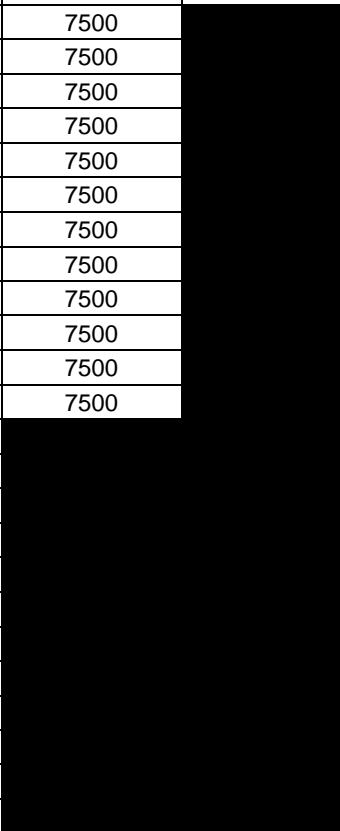
| Inlet Pressure (PSIG) | Outlet Pressure (PSIG) | Orifice Size | | |
|-----------------------|------------------------|--------------|------|--|
| | | 1/4" | 3/8" | 1/2" |
| 60 | 1 | 4600 | 7500 |  |
| | 2 | 4600 | 7500 | |
| | 5 | 4600 | 7500 | |
| | 10 | 4600 | 7500 | |
| | 15 | 4600 | 7500 | |
| | 20 | 4600 | 7500 | |
| 75 | 1 | 5600 | 7500 | |
| | 2 | 5600 | 7500 | |
| | 5 | 5600 | 7500 | |
| | 10 | 5600 | 7500 | |
| | 15 | 5600 | 7500 | |
| | 20 | 5600 | 7500 | |
| 100 | 1 | 7100 | | |
| | 2 | 7100 | | |
| | 5 | 7100 | | |
| | 10 | 7100 | | |
| | 15 | 7100 | | |
| | 20 | 7100 | | |
| 125 | 1 | 7500 | | |
| | 2 | 7500 | | |
| | 5 | 7500 | | |
| | 10 | 7500 | | |
| | 15 | 7500 | | |
| | 20 | 7500 | | |

Notes:

3/4-inch outlet pipe size limits the capacity to 2000 SCFH.

1-inch outlet pipe size limits to 3000 SCFH.

*Individual regulator performance may vary from data shown.

 Do not use this orifice at this inlet pressure.

CL231 Performance Curves

5, 10 PSIG Set Point

| | |
|-----------------------|----------|
| Type and model | CL231R |
| Inlet size | 2" NPT |
| Outlet size | 2" NPT |
| Orifice size | 3/8-inch |

All test results are reported at a base of 14.7 PSIA at 60°F and with 0.6 S.G. gas.

5 PSIG Set Point

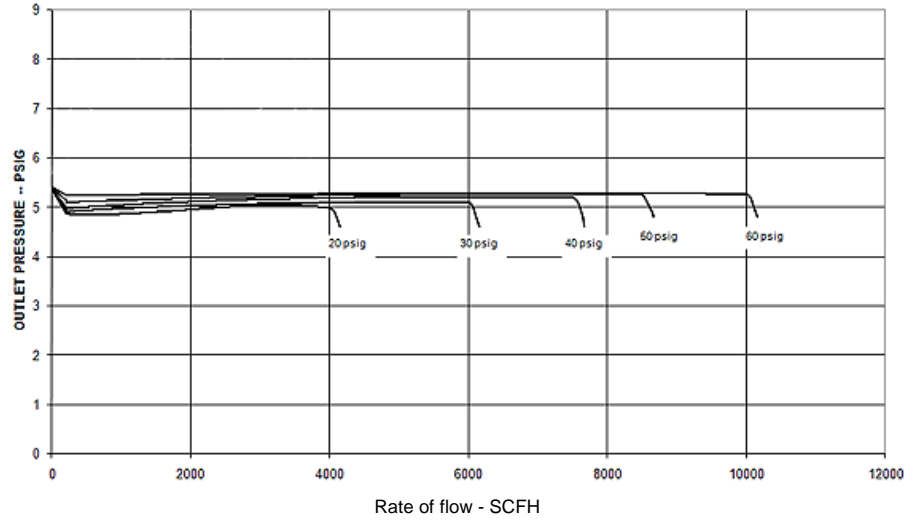

10 PSIG Set Point

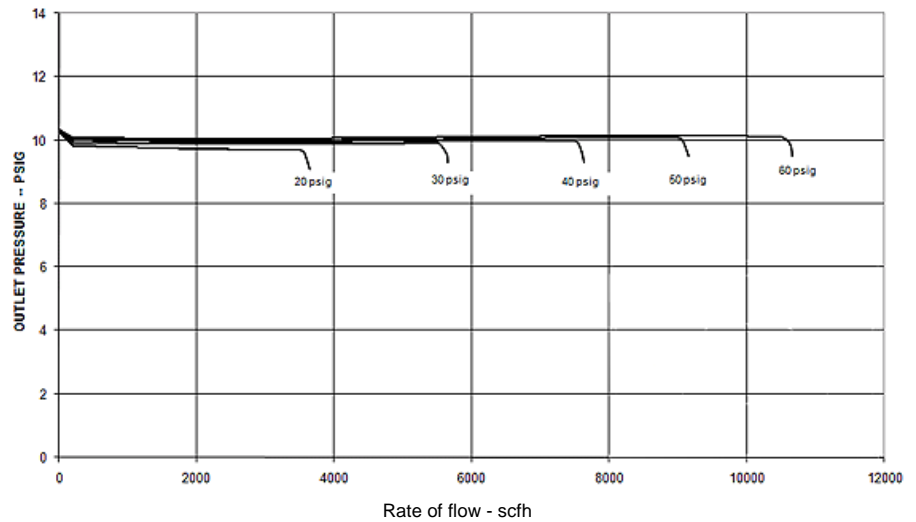

Assembly Positions

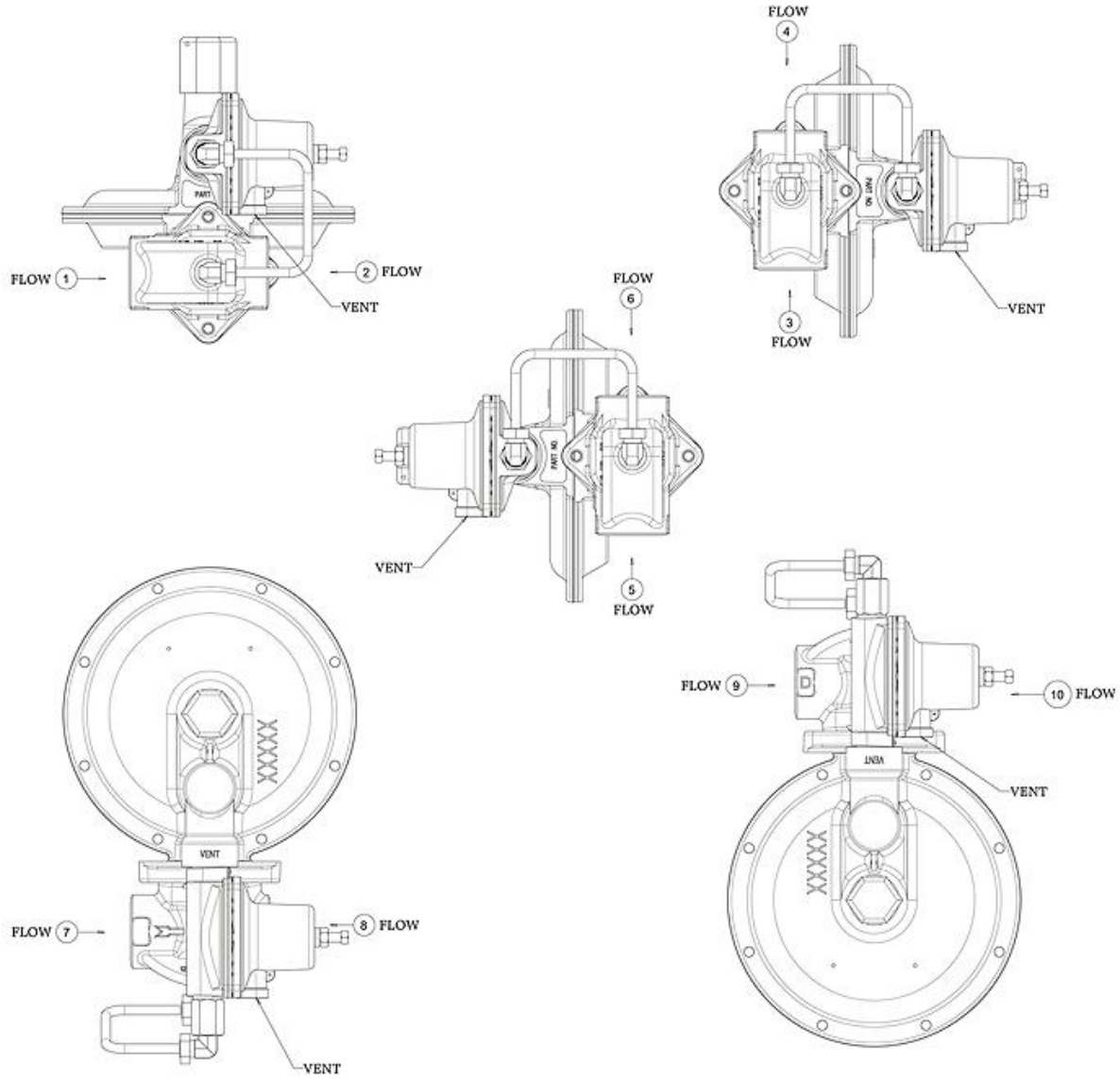

CL231 Parts List

CL231 R

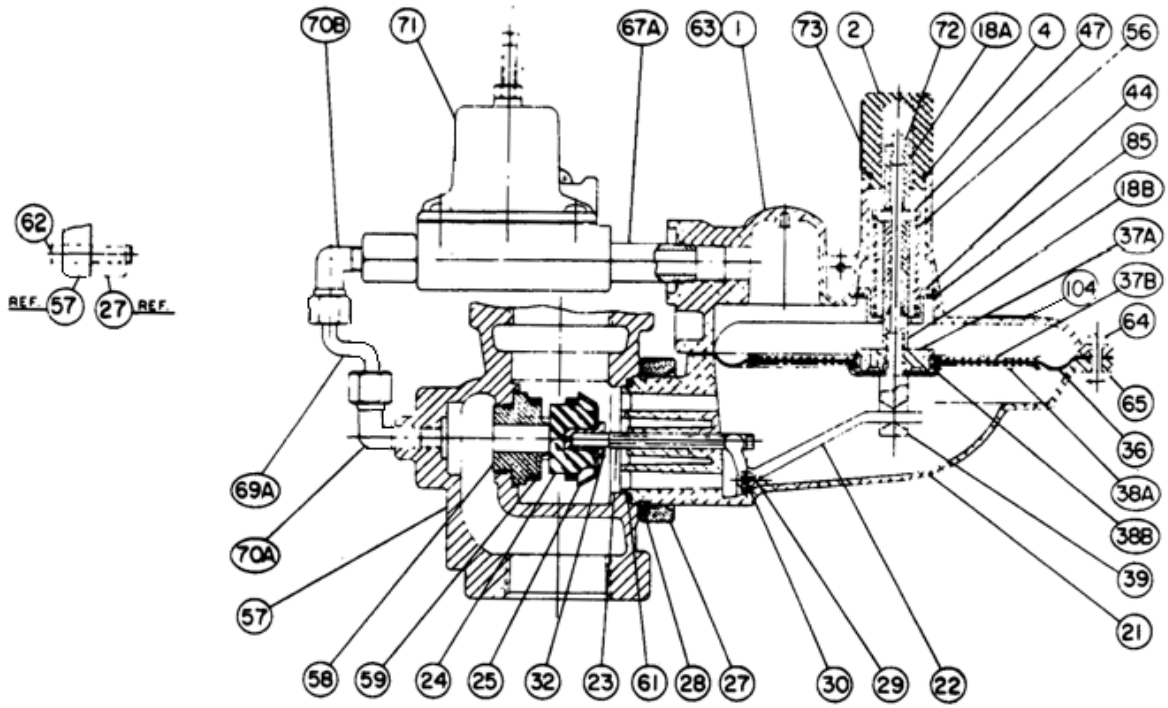

CL231 N

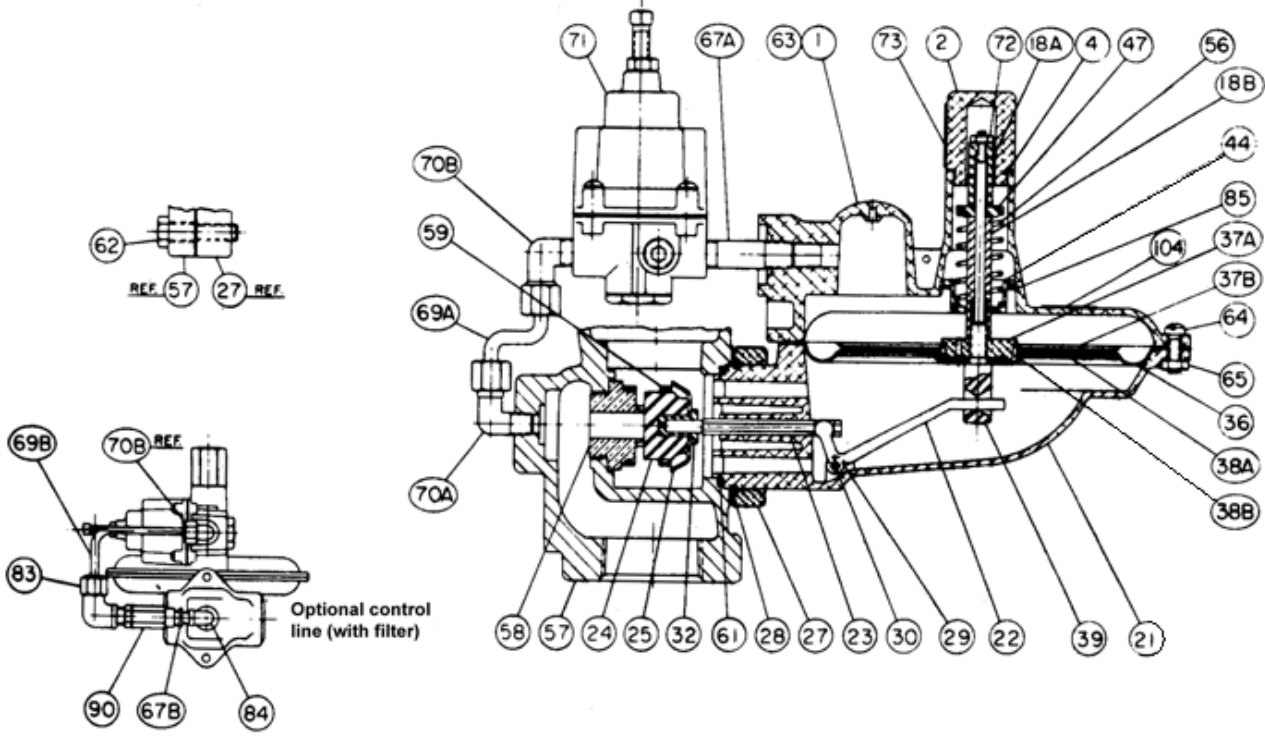

| Item No. | Part No. | Quantity Required per Regulator Model | | Description |
|----------|----------|---------------------------------------|---|--|
| | | N | R | |
| 1 | 753199 | | 1 | Upper diaphragm case, vent 3/8" ANPT pipe |
| | 753194 | 1 | 1 | Upper diaphragm case, vent 1/4" ANPT pipe |
| 2 | | | | Seal cap - specify type: |
| | 760001 | 1 | 1 | with seal wire hole - main spring seal cap |
| | 760003 | 1 | 1 | with no seal wire hole - main spring Seal Cap |
| | 760011 | 1 | 1 | with no seal wire hole - pilot seal cap (optional) |
| | 760013 | 1 | 1 | with seal wire hole - pilot seal cap (optional) |
| 4 | 765503 | 1 | 1 | Seal cap gasket |
| 18A | 754721 | 1 | 1 | Stop stem spacer - upper |
| 18B | 754725 | 1 | | Stop stem spacer - lower |
| 21 | 752124 | 1 | 1 | Lower diaphragm case - 4:1 lever ratio |
| 22 | 761231 | 1 | 1 | Valve linkage lever - 4:1 lever ratio |
| 23 | 754021 | 1 | 1 | Valve stem |
| 24 | 765203 | 1 | 1 | Valve seat - Buna-N |
| 25 | 761721 | 1 | 1 | Deflector ring |
| 27 | 751913 | 1 | 1 | Valve body retainer plate - aluminum |
| 28 | 755725 | 1 | 1 | Retainer plate snap ring |
| 29 | 755141 | 2 | 2 | Valve linkage pin screw |
| 30 | 754831 | 1 | 1 | Valve linkage pin |
| 32 | 754085 | 1 | 1 | Valve stem adapter |
| 36 | 766121 | 1 | 1 | Diaphragm |
| 37A | 761031 | 1 | 1 | Upper diaphragm plate |
| 37B | 761025 | 1 | 1 | Upper diaphragm plate |
| 38A | 761025 | 1 | 1 | Lower diaphragm plate |
| 38B | 756091 | 1 | 1 | Lower diaphragm plate |
| 39 | 754331 | 1 | 1 | Stop stem |
| 44 | 754901 | 1 | 1 | Stop stem guide bushing |
| 47 | 761495 | 1 | 1 | Closing spring guide |
| 56 | 762119 | 1 | 1 | Closing spring - light green |
| 57 | | 1 | 1 | Valve body, straight - specify type and size: |
| | 750613 | | | 1-1/4" x 1-1/4" NPT with 1/8" NPT |
| | 750636 | | | 1-1/4" x 1-1/2" NPT with 1/8" NPT |
| | 750663 | | | 1-1/4" x 2" NPT with 1/8" NPT |
| | 750690 | | | 1-1/2" x 1-1/2" NPT with 1/8" NPT |
| | 750713 | | | 1-1/2" x 2" NPT with 1/8" NPT |
| | 750741 | | | 2" x 2" NPT with 1/8" NPT |
| | 750763 | | | 2" ASA flanged 125 lb. with 1/8" NPT |
| | 750813 | | | 3" ASA flanged 125 lb. with 1/8" NPT |
| | 750786 | | | 2" ASA short flanged 125 lb. with 1/8" NPT |
| 58 | | 1 | 1 | Orifice - brass - specify size: |
| | 758101 | | | 1/4" diameter |
| | 758104 | | | 3/8" diameter |
| | 758107 | | | 1/2" diameter |
| 59 | 761761 | 1 | 1 | Loading Ring |
| 61 | 765651 | 1 | 1 | Valve body gasket |

| Item No. | Part No. | Quantity Required per Regulator Model | | Description |
|----------|----------|---------------------------------------|---|---|
| | | N | R | |
| 62 | 755381 | 2 | 2 | Retainer plate screw - hex head - 5/16" - 18 x 1-1/4" |
| 63 | 769205 | 1 | 1 | Curved two-hole regulator badge (optional) |
| 64 | 755304 | 8 | 8 | Case screw - hex head - 1/4" - 20 x 3/4" |
| 65 | 755661 | 8 | 8 | Case nut - hex - 1/4" - 20 |
| 67A | 768133 | | 1 | Nipple - 3/8" NPT x 2" |
| | 768123 | 1 | | Nipple - 1/4" NPT x 2" |
| 67B | 768101 | 1 | 1 | Pipe nipple, male - 1/8" x 1/4" NPT steel |
| 69A | 768501 | | | Control line - 1/4" steel |
| 69B | 768541 | 1 | 1 | Control line - 1/4" D tube steel |
| 70A | 768251 | 1 | 1 | 90° Male elbow - 1/4" tube x 1/8" NPTF steel |
| 70B | 768257 | 1 | 1 | 90° Male elbow - 1/4" tube x 1/4" NPTF steel *Optional control line with filter assembly |
| 71 | 700321 | 1 | | Regulator pilot - N type only - blue spring |
| | 762631 | | 1 | Orange - adjustment spring only |
| | 762633 | | 1 | Brown - adjustment spring only |
| | 762635 | | 1 | Green - adjustment spring only |
| | 762637 | | 1 | Black - adjustment spring only |
| | 762639 | | 1 | Blue - adjustment spring only |
| 72 | 755621 | 1 | 1 | Stop stem nut (hex) #10-24 |
| 73 | 769401 | 1 | 1 | Warning sticker - seal cap |
| 83 | 768251 | 1 | 1 | 90° Male elbow - 1/4" tube x 1/8" NPTF steel |
| 84 | 768291 | 1 | 1 | 90° Street elbow - 1/8" NPT - steel |
| 85 | 755731 | 1 | 1 | Stem guide bushing ret. ring |
| 90 | 768481 | 1 | 1 | Control line filter |

Vent Lines for Regulators

When constructing vent lines to be attached to regulators installed indoors, follow a few basic rules:

- a. Never use pipe sizes smaller than the vent size; smaller pipe sizes restrict the gas flow. If a long gas run must be used, Itron advises increasing the pipe one nominal size every ten feet to keep the flow restriction as low as possible.
- b. Keep the vent line length as short as possible to minimize the restriction and reduce the vent's tendency to cause regulator pulsation.
- c. Support the vent pipe to eliminate strain on the regulator diaphragm case.
- d. Always point outdoor vent pipes in the downward position to reduce the possibility of rain, snow, sleet, and other moisture entering the pipe. Install a bug screen in the end of the pipe.
- e. Do not locate the vent line terminus near windows, fans, or other ventilation equipment. See the installation instructions furnished with the regulator.
- f. Adhere to all applicable codes and regulations.
- g. If your vent pipe causes regulator pulsation, consult your sales representative or manufacturer.
- h. Itron strongly recommends running a separate vent line for each regulator. Headers with various installed devices can cause regulator malfunction.

Caution Ensure the end of the vent line is away from ANY potential ignition sources. It is the installer's responsibility to ensure the vent line is exhausting to a safe environment.

Installation

Warning Itron does not endorse or warrant the completeness or accuracy of any third party regulator installation procedures or practices, unless otherwise provided in writing by Itron. Follow your company's standard operating procedures regarding the use of personal protection equipment (PPE). Adhere to guidelines issued by your company in addition to those given in this document when installing regulators.

- a. Remove all shipping plugs from the regulator inlet, outlet, and vent before installation.
- b. Verify the piping interior and regulator inlet and outlet are clean and free of dirt, pipe dope, and other debris. Dirt and other foreign materials entering the regulator can cause a loss of pressure control.
- c. Apply pipe joint sealant to the male pipe threads. Do not use pipe joint material on the regulator's female threads. Joint sealant could become lodged in the regulator and cause a loss of pressure control.
- d. Gas must flow through the regulator's valve body in the direction cast on the regulator body. Gas flowing in the wrong direction can overpressure and cause damage to the regulator.
- e. The pilot diaphragm casing can be mounted in any position relative to the body through a full 360° angle at 90° increments.
- f. When the regulator is installed OUTDOORS, the vent must always be positioned so that rain, snow, moisture or foreign particles cannot enter the vent opening. Itron recommends positioning the pilot vent downward to avoid entry of water or other matter which could interfere with the proper operation of the regulator. The vent should be located away from building eaves, window openings, building air intakes and above the expected snow level at the site. The vent opening should be inspected periodically to insure it does not become blocked by foreign material as outlined in DOT PHMSA-RSPA-2004-19856.
- g. When the regulator is installed INDOORS, the vent must be piped to the outside atmosphere using the shortest length of pipe, the fewest possible pipe elbows, and a pipe diameter as large as the vent size or larger. USING VENT PIPE SMALLER THAN THE VENT CONNECTION LIMITS THE REGULATOR'S INTERNAL RELIEF VALVE CAPACITY. The outlet end of the pipe must be protected from moisture and the entrance of foreign particles. The regulator should be specified by the user with the size vent and pipe threads desired to make the vent pipe connection.

Start-up Procedure

- a. Mount a pressure gauge downstream of the regulator to monitor the downstream pressure.
- b. With the downstream pressure valve closed, slowly open the inlet valve. The outlet pressure should rise to slightly more than the set-point. Verify there are no leaks and all connections are tight.
- c. The regulator was pre-set at the factory to match order specifications. If necessary, adjust the outlet pressure by removing the seal cap on the top of the pilot spring housing and adjusting the ferrule or screw inside the pilot spring housing using a large flat-head screwdriver. With a small amount of gas flowing through the regulator, rotate the pilot ferrule clockwise to raise the outlet pressure or counter-clockwise to lower the outlet pressure.
- d. Replace the seal cap and check for leaks after the desired outlet pressure is achieved.

The regulator is ready for operation.

Safety Warning

This product, as of the date of manufacture, is designed and tested to conform to all governmental and industry safety standards as they may apply to the manufacturer. The purchaser/user of this product must comply with all fire control, building codes, and other safety regulations governing the application, installation, operation, and general use of this regulator to avoid leaking gas hazards resulting from improper installation, startup or use of this product.

Itron strongly recommends installation by a qualified professional and periodic inspection of pressure regulators (inspections may be required by local applicable codes or regulations).

Inspections should include checking for gas quality, cycle numbers, external environmental changes, and operating conditions that impact wear on the regulator's moving parts. To ensure safe and efficient operation of this product, replace worn or damaged parts found during inspection.

Limited Warranty

Itron, Inc. 970 Highway 127 North, Owenton, Kentucky 40359-9302, warrants this gas product against defects in materials and workmanship for the earlier of one (1) year from the date the product is shipped by Itron or a period of one year from the date the product is installed by Itron at the original purchaser's site. During such one-year period, provided that the original purchaser continues to own the product, Itron will, at its sole option, repair any defects, replace the product or repay the purchase price.

- > This warranty will be void if the purchaser fails to observe the procedures for installation, operation or service of the product as set forth in the Operating Manual and Specifications for the product or if the defect is caused by tampering, physical abuse or misuse of the product.
- > ITRON SPECIFICALLY DISCLAIMS ALL IMPLIED WARRANTIES INCLUDING THOSE OF MERCHANTABILITY OR OF FITNESS FOR A PARTICULAR PURPOSE. UNDER NO CIRCUMSTANCES WILL ITRON BE LIABLE FOR INCIDENTAL OR CONSEQUENTIAL DAMAGES OF ANY KIND WHATSOEVER.
- > Itron's liability for any claim of any kind, including negligence and breach of warranty for the sale and use of any product covered by or furnished, shall in no case exceed the price allocable to the product or part thereof which gives rise to the claim.

- > In the event of a malfunction of the product, consult your Itron Service Representative or Itron Inc., 970 Highway 127 North, Owenton, Kentucky 40359-9302. See Itron Terms and Conditions of Sale for the full and complete terms of the Limited Warranty.

Ordering Information

1. Inlet and outlet connection size and type
2. Model number
3. Outlet pressure desired
4. Inlet pressure range
5. Type of gas and maximum capacity required
6. Assembly position number (see diagram above)
7. Vent size
8. Special requirements such as tagging, pipe plug tap, seal wire, etc.

About Itron Inc.

Itron Inc. is a leading technology provider to the global energy and water industries. Our company is the world's leading provider of metering, data collection and utility software solutions, with nearly 8,000 utilities worldwide relying on our technology to optimize the delivery and use of energy and water. Our products include electricity, gas and water meters, data collection and communication systems, including automated meter reading (AMR) and advanced metering infrastructure (AMI); meter data management and related software applications; as well as project management, installation, and consulting services. To know more, start here: www.itron.com



Itron Gas

970 Highway 127 North
Owenton, Kentucky 40359
USA
Phone: 1.800.490.0657
1.502.484.5747
fax: 1.502.484.6223

Corporate Headquarters

2111 North Molter Road
Liberty Lake, WA 99019
USA
Phone: 1.800.635.5461
Fax: 1.509.891.3355
www.itron.com