

B838 Series Regulator

Twin Parallel Flow Service Regulators

Applications

The B838 series regulators are designed for commercial and industrial applications. The twin unit concept provides excellent control of widely varying inlet pressures and fluctuating flow rates. With the twin internal relief valves and internal monitor available, these regulators have unmatched over pressure protection, while providing significant cost savings from expensive piping and relief valve sets.

Description

- > B838N – The B838N is a spring loaded self operated regulator with no internal relief. This regulator can be used on low or intermediate inlet pressures where an internal relief valve is not required
- > B838R – The B838R is the largest internal relief service regulator. This model features twin 2-1/2" internal relief vents that allow the B838R to be used on any inlet system up to the regulator's maximum operating pressure rating
- > B838IMN – The B838IMN is equipped with an internal monitor (IM) orifice that operates upon failure of the main valve. This orifice features the safety advantage of a second gas-tight lock-up seat if the primary valve seat fails to produce the adjusted outlet pressure. The monitor also controls gas flow between the failed open flow and no flow, thereby providing complete secondary regulation. The "N" designation signifies no internal relief valve
- > B838IMR – The B838IMR is equipped with an internal monitor (IM) orifice as a primary form of overpressure protection that operates upon failure of the main valve seat. The B531IMR is also equipped with secondary twin internal relief valves that open in the event that both the main seat and the internal monitor cannot function
- > B838IMRV – The B838IMRV is equipped with an internal monitor (IM) orifice as a primary form of overpressure protection that operates upon failure of the main valve. It is also equipped with the vent-hole option, which gives a warning indication that the regulator is on monitor control in the event of main valve

failure. The vent-hole option consists of a 1/16" hole in the sliding orifice that allows a small amount of gas to bleed downstream, which causes the relief valves to weep gas. In the unlikely event the main valve and the monitor valve fails to function, the B531IMRV is equipped with secondary or back-up twin internal relief valves

Option Designations

- N - No internal relief
- R - Internal relief
- IMN - Internal monitor without internal relief
- IMR - Internal monitor with internal relief
- IMRV - Internal monitor with internal relief and vent

Benefits

- > Eliminates parallel regulator piping installations
Light weight
- > Fast response protects equipment from shock damage
- > Field inspection of the internal monitor and internal relief valves without customer shut-off or by-pass
- > Unmatched overpressure protection with internal monitor plus internal relief options

Features

- > Interchangeable brass orifice
- > Combined 226 in² of diaphragm area
- > Twin Spring-loaded internal relief valve assemblies
- > Field interchangeable adjustment springs
- > No special adjustment tools required
- > Controlled size breather orifice eliminates pulsation and provides normal actuation at low flows
- > Wide range of valve body sizes

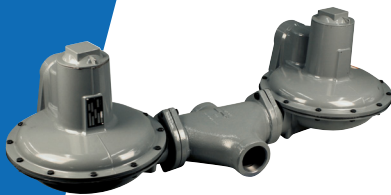

Shipping weight

One regulator per box

Size	Box weight
2" x 2" NPT	57 lbs.
2" x 2" Flanged	59 lbs.
2" x 3" Flanged	70 lbs.
2" x 4" Flanged	80 lbs.

B838 Dimensions

Valve body	A	B	C	D	E	F	G	H
1-1/2-inch, 2-inch or 3-inch	25	13	37-3/4	12-3/4	18-7/8	12-7/8	6-1/2	16-1/4

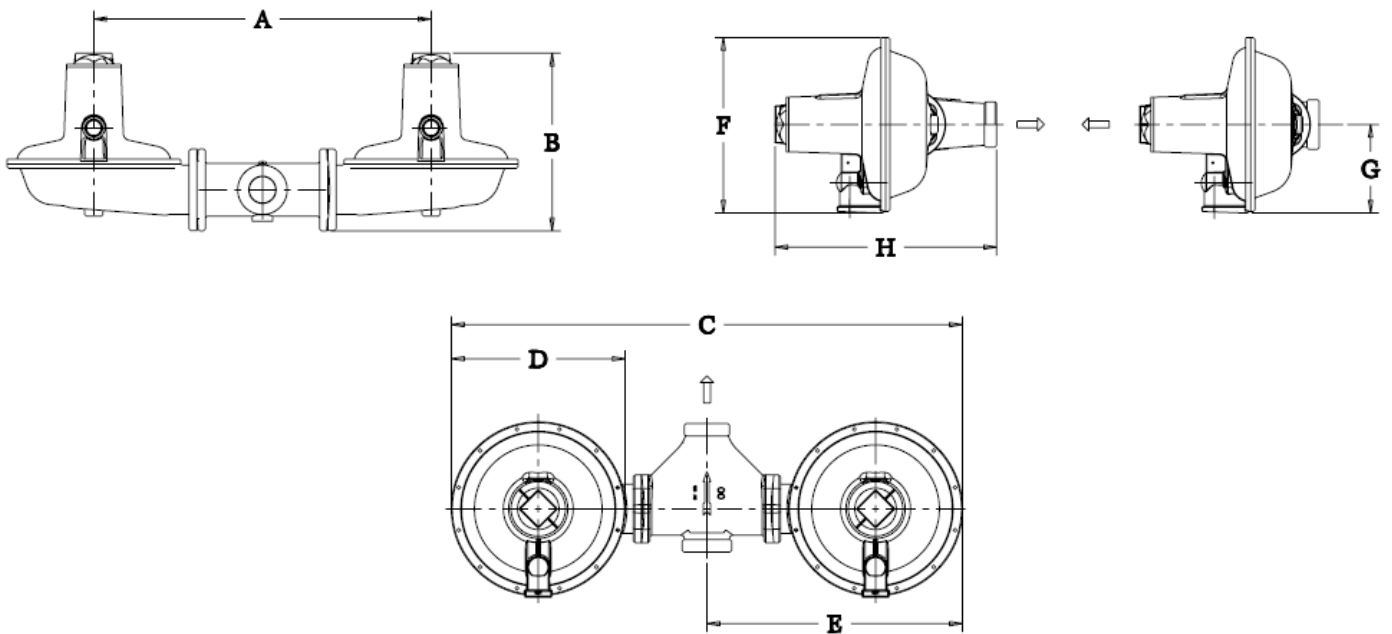

Operational Schematic

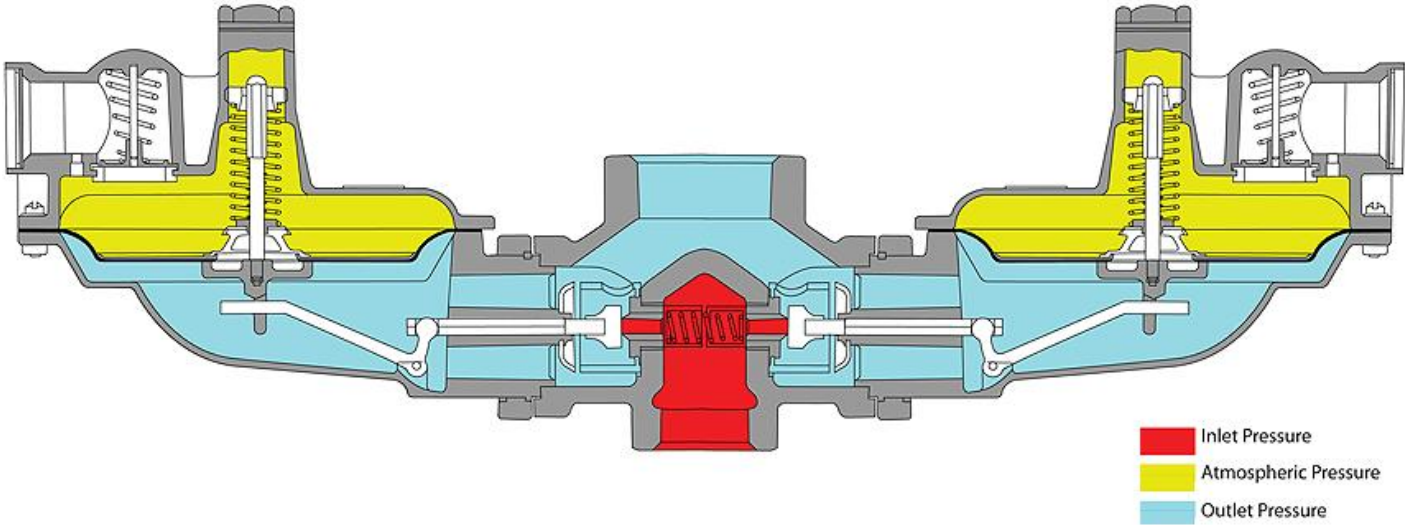

Spring Data - Spring Color Outlet Pressure Range – Models B838 N and R

B838N Adjusted Outlet Pressure Range* | B838R Adjusted Outlet Pressure Range*

Spring adjustment ferrule at minimum and maximum depths

Orifice size	Inlet pressure	Spring color	Outlet pressure			
			Minimum	Maximum	Minimum	Maximum
3/8"	25 PSIG	Orange	2.6" w.c.	5.0" w.c.	2.6" w.c.	4.3" w.c.
		Brown	3.7" w.c.	7.8" w.c.	4.5" w.c.	7.4" w.c.
		Green	4.1" w.c.	10.2" w.c.	4.8" w.c.	8.5" w.c.
		Black	6.3" w.c.	16.7" w.c.	7.9" w.c.	14.5" w.c.
		Blue	.5 PSIG	1.4 PSIG	.6 PSIG	1.1 PSIG
		Silver	1.4 PSIG	3.2 PSIG	1.0 PSIG	2.1 PSIG
		Yellow	2.9 PSIG	4.9 PSIG	2.8 PSIG	4.9 PSIG
		Red	2.9 PSIG	6.3 PSIG*	3.3 PSIG	6.2 PSIG*
1/2"	25 PSIG	Orange	2.7" w.c.	5.0" w.c.	2.7" w.c.	4.3" w.c.
		Brown	3.9" w.c.	8.2" w.c.	4.8" w.c.	7.8" w.c.
		Green	4.5" w.c.	10.7" w.c.	5.3" w.c.	8.9" w.c.
		Black	6.8" w.c.	18.0" w.c.	8.5" w.c.	15.6" w.c.
		Blue	.6 PSIG	1.5 PSIG	.7 PSIG	1.2 PSIG
		Silver	1.4 PSIG	3.3 PSIG	1.0 PSIG	2.1 PSIG
		Yellow	2.3 PSIG	4.5 PSIG	2.2 PSIG	4.5 PSIG
		Red	2.9 PSIG	6.4 PSIG*	3.3 PSIG	6.2 PSIG*
5/8"	25 PSIG	Orange	2.8" w.c.	5.8" w.c.	3.0" w.c.	4.6" w.c.
		Brown	4.3" w.c.	9.2" w.c.	5.1" w.c.	8.1" w.c.
		Green	5.2" w.c.	11.8" w.c.	5.6" w.c.	9.3" w.c.
		Black	7.8" w.c.	19.8" w.c.	8.9" w.c.	16.0" w.c.
		Blue	.6 PSIG	1.7 PSIG	.7 PSIG	1.2 PSIG
		Silver	1.5 PSIG	3.6 PSIG	1.1 PSIG	2.2 PSIG
		Yellow	2.3 PSIG	4.5 PSIG	2.2 PSIG	4.6 PSIG
		Red	3.0 PSIG	7.2 PSIG*	3.3 PSIG	6.3 PSIG*
3/4"	25 PSIG	Orange	3.0" w.c.	6.2" w.c.	3.5" w.c.	4.9" w.c.
		Brown	4.7" w.c.	9.6" w.c.	5.5" w.c.	8.6" w.c.
		Green	5.7" w.c.	12.3" w.c.	6.0" w.c.	9.5" w.c.
		Black	8.7" w.c.	20.1" w.c.	9.2" w.c.	16.3" w.c.
		Blue	.7" w.c.	1.7" w.c.	.7 PSIG	1.2 PSIG
		Silver	1.5" PSIG	3.6 PSIG	1.1 PSIG	2.2 PSIG
		Yellow	2.3 PSIG	4.5 PSIG	2.2 PSIG	4.6 PSIG
		Red	3.0 PSIG	7.5 PSIG*	3.4 PSIG	6.3 PSIG*

* Maximum allowable outlet pressure is 5.00 PSIG

B838N Adjusted Outlet Pressure Range (continued)* | **B838R Adjusted Outlet Pressure Range***
Spring adjustment ferrule at minimum and maximum depths

Orifice size	Inlet pressure	Spring color	Outlet pressure			
			Minimum	Maximum	Minimum	Maximum
1"	25 PSIG	Orange	4.3" w.c.	7.2" w.c.	4.2" w.c.	5.6" w.c.
		Brown	5.9" w.c.	10.8" w.c.	6.2" w.c.	9.3" w.c.
		Green	6.8" w.c.	13.3" w.c.	6.9" w.c.	10.2" w.c.
		Black	9.6" w.c.	21.5" w.c.	10.1" w.c.	17.3" w.c.
		Blue	.7 PSIG	1.7 PSIG	.7 PSIG	1.2 PSIG
		Silver	1.5 PSIG	3.7 PSIG	1.1 PSIG	2.3 PSIG
		Yellow	2.3 PSIG	4.5 PSIG	2.3 PSIG	4.7 PSIG
		Red	3.0 PSIG	7.1 PSIG*	3.4 PSIG	6.4 PSIG*
1-1/4"	10 PSIG	Orange	3.2" w.c.	6.4" w.c.	3.5" w.c.	5.0" w.c.
		Brown	4.7" w.c.	9.6" w.c.	5.7" w.c.	8.6" w.c.
		Green	5.6" w.c.	12.2" w.c.	6.2" w.c.	9.7" w.c.
		Black	8.4" w.c.	20.0" w.c.	9.2" w.c.	16.5" w.c.
		Blue	.6 PSIG	1.6 PSIG	.7 PSIG	1.2 PSIG
		Silver	1.4 PSIG	3.5 PSIG	1.1 PSIG	2.2 PSIG
		Yellow	2.3 PSIG	4.5 PSIG	2.2 PSIG	4.5 PSIG
		Red	2.9 PSIG	6.2 PSIG*	3.2 PSIG	6.3 PSIG*

* Maximum allowable outlet pressure is 5.00 PSIG

Spring Data - Spring Color Outlet Pressure Range – Models B838 IMN and IMR

B838IMN - Adjusted Outlet Pressure Range | **B838IMR - Adjusted Outlet Pressure Range**
Spring adjustment ferrule at min. and max. depths

Orifice size	Inlet pressure	Spring color	Outlet pressure			
			Minimum	Maximum	Minimum	Maximum
3/8"	25 PSIG	Orange	2.6" w.c.	4.5" w.c.	2.7" w.c.	4.2" w.c.
		Brown	3.6" w.c.	7.2" w.c.	4.0" w.c.	6.9" w.c.
		Green/white	4.7" w.c.	8.9" w.c.	5.3" w.c.	8.1" w.c.
		Black	4.9" w.c.	14.3" w.c.	6.7" w.c.	12.9" w.c.
		Blue	0.3 PSIG	1.0 PSIG	0.5 PSIG	1.0 PSIG
		Silver	0.8 PSIG	2.4 PSIG	1.1 PSIG	2.1 PSIG
		Yellow	1.5 PSIG	4.7 PSIG	2.3 PSIG	4.3 PSIG
		Red	1.6 PSIG	6.0 PSIG*	2.2 PSIG	5.0 PSIG*

* Maximum allowable outlet pressure is 5.00 PSIG

B838IMN - Adjusted Outlet Pressure Range continued

B838IMR - Adjusted Outlet Pressure Range continued

Spring adjustment ferrule at min. and max. depths

Orifice size	Inlet pressure	Spring color	Outlet pressure			
			Minimum	Maximum	Minimum	Maximum
1/2"	25 PSIG	Orange	2.6" w.c.	4.5" w.c.	2.8" w.c.	4.3" w.c.
		Brown	3.6" w.c.	7.2" w.c.	4.2" w.c.	7.0" w.c.
		Green/white	4.7" w.c.	8.9" w.c.	5.3" w.c.	8.2" w.c.
		Black	4.9" w.c.	14.3" w.c.	6.8" w.c.	13.1" w.c.
		Blue	0.3 PSIG	1.0 PSIG	0.5 PSIG	1.0 PSIG
		Silver	0.8 PSIG	2.4 PSIG	1.2 PSIG	2.2 PSIG
		Yellow	1.5 PSIG	4.7 PSIG	2.4 PSIG	4.3 PSIG
		Red	1.6 PSIG	6.0 PSIG*	2.4 PSIG	5.0 PSIG*
5/8"	25 PSIG	Orange	2.7" w.c.	4.9" w.c.	2.9" w.c.	4.6" w.c.
		Brown	4.2" w.c.	7.4" w.c.	4.5" w.c.	7.0" w.c.
		Green/white	4.6" w.c.	9.2" w.c.	6.0" w.c.	8.7" w.c.
		Black	4.7" w.c.	14.5" w.c.	7.3" w.c.	13.4" w.c.
		Blue	0.3 PSIG	1.1 PSIG	0.5 PSIG	1.0 PSIG
		Silver	0.8 PSIG	2.4 PSIG	1.2 PSIG	2.2 PSIG
		Yellow	0.5 PSIG	4.8 PSIG	2.4 PSIG	4.4 PSIG
		Red	1.6 PSIG	6.0 PSIG*	2.6 PSIG	5.1 PSIG*
3/4"	25 PSIG	Orange	3.2" w.c.	5.5" w.c.	3.6" w.c.	4.8" w.c.
		Brown	4.6" w.c.	8.0" w.c.	4.6" w.c.	7.4" w.c.
		Green/white	5.1" w.c.	10.0" w.c.	5.9" w.c.	9.2" w.c.
		Black	5.2" w.c.	15.1" w.c.	7.0" w.c.	13.6" w.c.
		Blue	0.3 PSIG	1.1 PSIG	0.5 PSIG	1.0 PSIG
		Silver	0.8 PSIG	2.5 PSIG	1.2 PSIG	2.2 PSIG
		Yellow	1.7 PSIG	4.9 PSIG	2.4 PSIG	4.4 PSIG
		Red	1.7 PSIG	6.1 PSIG*	2.5 PSIG	5.4 PSIG*
1"	10 PSIG	Orange	3.3" w.c.	6.0" w.c.	3.3" w.c.	4.6" w.c.
		Brown	3.4" w.c.	7.6" w.c.	4.6" w.c.	7.2" w.c.
		Green/white	4.7" w.c.	9.5" w.c.	5.9" w.c.	8.8" w.c.
		Black	4.9" w.c.	14.7" w.c.	7.0" w.c.	13.3" w.c.
		Blue	0.3PSIG	1.1 PSIG	0.5 PSIG	1.0 PSIG
		Silver	0.8 PSIG	2.4 PSIG	1.1 PSIG	2.2 PSIG
		Yellow	1.6 PSIG	4.8 PSIG	2.2 PSIG	4.2 PSIG
		Red	1.7 PSIG	6.0 PSIG*	2.3 PSIG	5.3 PSIG*

* Maximum allowable outlet pressure is 5.00 PSIG

Orifice Data - Wide Open Flow Coefficients and Maximum Pressure Data

Orifice Size (inches)	K-factors	Maximum Operating Inlet Pressure R Models		Max Emergency Inlet Pressure	Max. Emergency Outlet Pressure (containment)	
		In w.c. delivery	PSIG delivery	All outlet		
		Pressure PSIG	Pressure PSIG	Inlet pressure PSIG	In w.c. delivery	PSIG delivery
3/8	6	25	125	125	30	30
1/2	11	25	75	125		
5/8	14.5	25	75	60		
3/4	20	25	60	60		
1	29	10	45	30		

Operating Temperature

- 20°F to 150°F

Additional Specifications

Available pilot vent sizes	1" NPT on non-internal relief (N) models only 2-1/2" NPT (standard) on internal relief (R) models only 2" NPT (optional) Warning: the 2" relief size will reduce relief capacity
Loading ring position	For outlet pressure \geq 1 PSIG: 0° For outlet pressure <1 PSIG: varies
Other available options	Seal wire to indicate unapproved tampering 1/8" pipe plug tap on upstream side of valve body

Itron takes pride in delivering American made products with the utmost concern for safety, quality, and customer satisfaction.

Construction materials:

Valve bodies	High tensile strength cast iron (ASTM A-126, Class A)
Orifices	Brass
Valve seats	Buna-N
Valve stems	Nylon
Lever pins	Stainless steel (type 303)
Levers	Zinc and dichromate plated steel (AISI C1010)
Upper diaphragm plates	Zinc and dichromate plated steel (14-gauge steel)
Lower diaphragm plates	Die cast aluminum (ASTM B-85 Alloy SC84A)
Diaphragms	Buna-N reinforcing fiber
Vent valves/seats	Neoprene
Vent screen	Stainless steel (16 mesh)
Adjustment ferrules	Acetal
Seal caps	ABS plastic
Diaphragm cases	Die cast aluminum (ASTM B85 - Alloy SC84A)
Valve stem inserts	Acetal

Valve Body Sizes

Inlet	Outlet	NPT	Flanged
2"	2"	X	X
2"	3"		X
2"	4"		X

X-indicates the valve body is available in that configuration.

Correction factors for non-natural gas applications

The B838 may be used to control gases other than natural gas. To determine the capacity for gases other than natural gas, multiply the values within the capacity tables by a correction factor. The table below lists the correction factors for some of the more common gases:

Gas Type	Specific Gravity	Correction Factor (CF)
Air	1.00	0.77
Butane	2.01	0.55
Carbon Dioxide (Dry)	1.52	0.63
Carbon Monoxide (Dry)	0.97	0.79
Natural Gas	0.60	1.00
Nitrogen	0.97	0.79
Propane	1.53	0.63
Propane-Air-Mix	1.20	0.71

To calculate the correction factor for gases not listed in the table above, use the gases' specific gravity and insert it in the formula listed below:

$$\text{Correction Factor (CF)} = \sqrt{\frac{SG_1}{SG_2}}$$

Where:

SG₁ = Specific gravity of the gas in which the capacity is published.

SG₂ = Specific gravity of the gas to be controlled.

Wide Open Flow Calculations

For wide-open orifice flow calculations use the following equations:

$$\text{For } P_1/P_2 < 1.89 \text{ use: } Q = K\sqrt{P_2(P_1 - P_2)} \quad \text{For } P_1/P_2 > 1.89 \text{ use: } Q = \frac{KP_1}{2}$$

Where: P₁ = Absolute Inlet Pressure (PSIA)

P₂ = Absolute Outlet Pressure (PSIA)

Q = Flow Rate (SCFH)

K = Orifice Coefficient (SCFH/PSI)

B838 R, N, D, M Twin Parallel Flow Service Regulator

Capacity Table, 2" x 2"

Outlet Pressure		7" w.c.	7" w.c.	11" w.c.	11" w.c.	1 PSIG	2 PSIG	2 PSIG	2 PSIG	5 PSIG	5 PSIG	5 PSIG
Pressure Droop		1" w.c.	1" w.c.	2" w.c.	2" w.c.	0.2 PSIG	1% ABS	2% ABS	WO	1% ABS	2% ABS	WO
Orifice Size (in inches)	Inlet Pressure PSIG	Flow rate, SCFH of .60 Wp. Gr. gas @ 14.7 PSIA and 60°F										
Loading Ring Setting		0°		0°		0°	0°	0°	0°	0°	0°	0°
1-1/4 K = 2925	1	4750		5350		6900						
	2	6400		7200		9200	3800	6200	11950			
	3	8500		9200		12100	5600	9500	20705			
	5	11500	N.C.	11750	N.C.	18000	9300	14000	33785	5200	8000	29015
	10	18000		16000		20000	11700	16300	43085	7000	10900	41040
	15	20000		20000		20000	17400	20000	58060	9500	15200	58060
	25	20000		20000		20000	20000	20000	20000	20000	20000	20000
Loading Ring Setting		0°	29°	0°	25°	0°	0°	0°	0°	0°	0°	0°
1 K = 2290	1	4000	3200	3750	3200							
	2	5950	5000	6000	5100	5550						
	3	7300	6000	7600	6500	8450	3300	5550	9355			
	5	10900	7800	10650	8700	10950	4550	7950	16210			
	10	15100	11600	15000	13000	15100	7450	12000	26450	3850	5750	22715
	15	20000	17400	20000	19000	20000	9700	14700	33730	5200	8000	32130
	25		20000		20000	20000	15800	19800	45455	8750	13500	45455
	45		20000		20000	20000	20000	20000	68355	12500	18100	68355
Loading Ring Setting		0°	32°	0°	32°	0°	0°	0°	0°	0°	0°	0°
3/4 K = 1640	1	3000	2850	2500	2350							
	2	3750	3400	4200	4050	4000						
	3	5150	4400	5500	5250	6200	2750	4150	6700			
	5	7800	6100	8300	7650	7900	4000	6500	11610			
	10	11250	10600	11700	10500	12600	6400	10000	18940	3850	5500	16270
	15	15250	13900	15700	13500	15800	8500	13200	24155	4800	7400	23010
	25		19000		20000	20000	12000	17200	32555	8100	12000	32555
	60		2000		20000	20000	20000	20000	61255	14800	20000	61255
Loading Ring Setting		0°	36°	0°	36°	0°	0°	0°	0°	0°	0°	0°
5/8 K = 1230	1	2000	1850	2000	2050							
	2	3500	2900	3250	3200	2800						
	3	4750	3500	4400	4250	3800	2450	3700	5025			
	5	6700	5150	6450	5850	5600	3500	5250	5705			
	10	9800	7400	10200	9300	5700	5800	8600	14205	3150	4600	12200
	15	12900	9850	13350	11000	11500	7500	11100	18120	4100	6000	17225
	25		14000		16100	17000	11300	15300	24415	6200	9400	24415
	60		20000		20000	20000	19100	20000	45940	12750	18150	45940
75		20000		20000	20000	20000	20000	55165	14300	20000	55165	

N.C. No change needed in loading ring setting.

K-factors are wide open.

B838 R, N, D, M Twin Parallel Flow Service Regulator

Capacity Table, 2" x 2" continued

Outlet Pressure		7" w.c.	7" w.c.	11" w.c.	11" w.c.	1 PSIG	2 PSIG	2 PSIG	2 PSIG	5 PSIG	5 PSIG	5 PSIG
Pressure Droop		1" w.c.	1" w.c.	2" w.c.	2" w.c.	0.2 PSIG	1% ABS	2% ABS	WO	1% ABS	2% ABS	WO
Loading Ring Setting		0°		0°		0°	0°	0°	0°	0°	0°	0°
Orifice Size (in inches)	Inlet Pressure PSIG	Flow rate, SCFH of .60 Wp. Gr. gas @ 14.7 PSIA and 60°F										
Loading Ring Setting		0°	36°	0°	40°	0°	0°	0°	0°	0°	0°	0°
1/2	1	1600	1550	1500	1450							
	2	2500	2300	2300	2250	2350						
	3	3500	3000	3400	3200	3200	1850	2600	3670			
	5	5000	3800	4800	4450	4300	2950	4000	6370			
	10	8700	6000	7550	6700	7000	4600	7050	10395	2650	3250	8930
	15	10100	7300	9800	8000	9300	6800	8750	13255	3700	5000	12625
	25	12250	10500	13100	10800	12800	10400	13400	17865	5400	7550	17865
	60		19200		20000	20000	17400	20000	33615	9600	14700	33615
	75		20000		20000	20000	20000	40365	13000	18700	40365	
Loading Ring Setting		0°	25°	0°	32°	0°	0°	0°	0°	0°	0°	0°
3/8	1	1400	1400	1400	1300							
	2	2150	1850	2150	2050	1850						
	3	2750	2450	2700	2450	2450	1350	2050	2800			
	5	3600	3400	3450	3400	3450	2350	3000	4250			
	10	5400	4900	5300	4700	5050	3400	4450	6930	2050	2650	5950
	15	6850	5900	6650	5950	6650	4400	6250	8840	2700	3550	8420
	25	10200	8500	10100	8300	9500	6400	8900	11910	3600	5000	11910
	60		15300	18300	15400	18300	13200	17800	22410	6500	10600	22410
	75		17400		17700	20000	14900	19800	26910	7400	12200	26910
	100		20000		20000	20000	17300	20000	34410	9800	15300	34410
	125		20000		20000	20000	20000	20000	41910	11300	20000	41910

K-factors are wide open.

B838 R, N, D, M Twin Parallel Flow Service Regulator
Capacity Table, 2" x 3"

Outlet Pressure		7" w.c.	7" w.c.	11" w.c.	11" w.c.	1 PSIG	2 PSIG	2 PSIG	2 PSIG	5 PSIG	5 PSIG	5 PSIG
Pressure Droop		1" w.c.	1" w.c.	2" w.c.	2" w.c.	0.2 PSIG	1% ABS	2% ABS	WO	1% ABS	2% ABS	WO
Orifice Size (inches)	Inlet Pressure PSIG	Flow rate, SCFH of .60 Wp. Gr. gas @ 14.7 PSIA and 60°F										
Loading Ring Setting		0°	40°	0°	43°	0°	0°	0°	0°	0°	0°	0°
1-1/4 K = 3400	1	5600	5400	5450	5650							
	2	9600	8450	8800	8500	7800						
	3	13200	11000	11600	11000	11800	5500	8000	13890			
	5	18900	17400	16700	16100	17000	9100	12900	24065			
	10		29100	28000	26200	27700	15600	22200	39270	5500	8600	33730
	15		38500	37100	34500	36500	22300	33400	50080	7300	11700	47700
	25		40000		40000	40000	39500	40000	67490	13100	23200	67490
	30		40000		40000	40000	40000	40000	75990	18000	27400	75990
Loading Ring Setting		0°	46°	0°	43°	0°	0°	0°	0°	0°	0°	0°
1 K = 2900	1	4450	3800	4400	4200							
	2	7300	6500	7400	7200	6500						
	3	10650	8500	10300	9000	9300	5100	6800	11850			
	5	16400	14400	14800	12200	13650	7100	10600	20525			
	10	23800	23000	23300	19600	22500	12600	18500	33495	4900	7600	28770
	15		29900	30100	26500	29200	17100	23000	42715	6600	10100	40685
	25		40000		40000	40000	28800	39000	57565	11500	18400	57565
	45		40000		40000	40000	40000	40000	86565	21200	34000	86565
Loading Ring Setting		0°	46°	0°	45°	0°	0°	0°	0°	0°	0°	0°
3/4 K = 2000	1	3500	3100	3100	2900							
	2	5500	4500	5000	4750	4300						
	3	7500	6400	7050	6450	6450	4100	6000	8170			
	5	13100	10200	11850	9200	10200	5900	8250	14155			
	10	19000	18100	19700	17000	17050	9600	13700	23100	3700	6050	19840
	15	26500	25250	26400	23700	23800	13200	19800	29460	5300	8500	28060
	25		40000		38000	38200	23900	32000	39700	8400	13800	39700
	60		40000		40000	40000	40000	40000	74700	20200	35500	74700
Loading Ring Setting		0°	48°	0°	43°	0°	0°	0°	0°	0°	0°	0°
5/8 K = 1450	1	2300	2100	2200	2100							
	2	3950	3200	3700	3500	3000						
	3	5600	4300	5000	4750	4550	3400	4650	5925			
	5	7350	6100	7550	6500	6100	4900	6650	10265			
	10	14200	11800	14400	12000	11950	7200	10900	16750	3200	4800	14385
	15	20400	17400	20000	17000	16000	11300	14000	21360	4850	7100	20345
	25		28850	34300	29100	27450	14400	22000	28785	7200	11100	28785
	60		40000		40000	40000	34000	40000	54160	16800	24600	54160
75		40000		40000	40000	40000	40000	65035	19800	32000	65035	

K-factors are wide open.

B838 R, N, D, M Twin Parallel Flow Service Regulator

Capacity Table, 2" x 3" continued

Outlet Pressure		7" w.c.	7" w.c.	11" w.c.	11" w.c.	1 PSIG	2 PSIG	2 PSIG	2 PSIG	5 PSIG	5 PSIG	5 PSIG
Pressure Droop		1" w.c.	1" w.c.	2" w.c.	2" w.c.	0.2 PSIG	1% ABS	2% ABS	WO	1% ABS	2% ABS	WO
Loading Ring Setting		0°	48°	0°	45°	0°	0°	0°	0°	0°	0°	0°
Orifice Size (inches)	Inlet Pressure PSIG	Flow rate, SCFH of .60 Wp. Gr. gas @ 14.7 PSIA and 60°F										
1/2 K = 1100	1	1650	1550	1500	1450							
	2	2500	2300	2650	2250	2450						
	3	3500	3000	3750	3500	3600	2800	3800	4495			
	5	5450	4400	6000	4650	5100	4450	4700	7785			
	10	10500	6850	8900	7450	7550	6050	7200	12705	2850	4100	10910
	15	13800	8500	12100	11100	11100	7800	11100	16205	3800	5300	15435
	25	21000	16600	19700	17600	17400	13000	17300	21835	5800	8800	21835
	60		36600		38800	68400	28000	33000	41085	12100	18800	41085
	75		40000		40000	40000	35000	40000	49335	17500	24400	49335
Loading Ring Setting		0°	25°	0°	32°	0°	0°	0°	0°	0°	0°	0°
3/8 K = 600	1	1400		1400								
	2	2150		2150		1850						
	3	2800		2700		2450	1700	2050	2800			
	5	3700		3650		3450	2600	3200	4250			
	10	5900		5800		5050	3900	5200	6930	2200	3000	5950
	15	7450	N.C.	7300	N.C.	6650	5200	6650	8840	3000	4100	8420
	25	10900		10500		9500	8600	10750	11910	4300	6100	11910
	60	21400		21400		19000	19200	20600	22410	8000	12600	22410
	75	26000		26000		25400	14800	26200	26910	10800	17100	26910
	100	30000		30000		29800	26400	28500	34410	12000	19000	34410
	125	35000		35000		34700	31200	34600	41910	15700	23000	41910

N.C. No change needed in loading ring setting.

K-factors are wide open.

B838 Performance Curves

7" w.c. Set Point

Type and model B838
 Inlet size 2" Flanged
 Outlet size 4" Flanged
 Orifice size 1-1/4"

All test results are reported at a base of 14.7 PSIG at 60° F and with 0.6 S.G. gas.

B838 Performance Curves

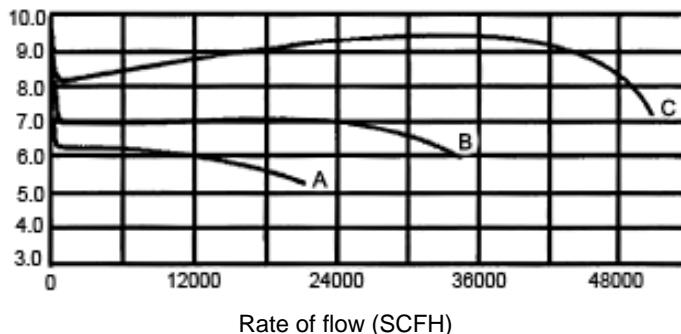

7" w.c. Set Point

Type and model B838
 Regulator:
 Inlet size 2" Flanged
 Outlet size 4" Flanged
 Vent size

All test results are reported at a base of 14.7 PSIG at 60° F and with 0.6 S.G. gas.

B838 Relief Curves

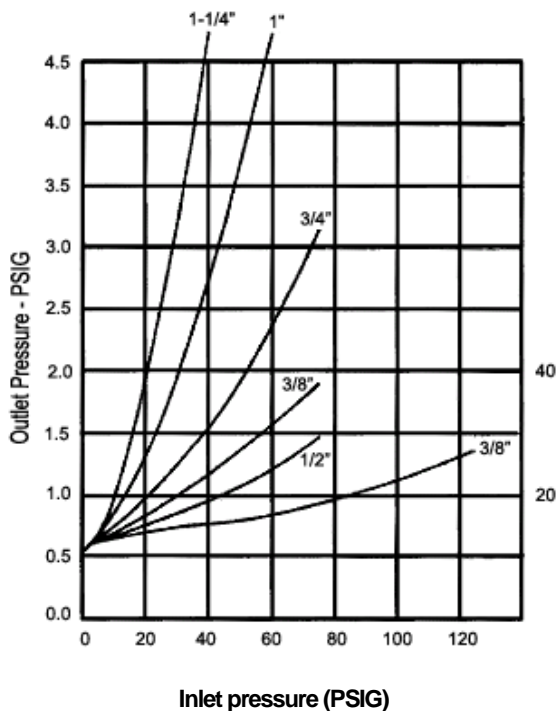

B838 Relief Curves

2 PSIG Set Point

Type and model B838
Inlet size 2" Flanged
Outlet size 4" Flanged
Orifice size 1-1/4"

All test results are reported at a base of 14.7 PSIG at 60° F and with 0.6 S.G. gas.

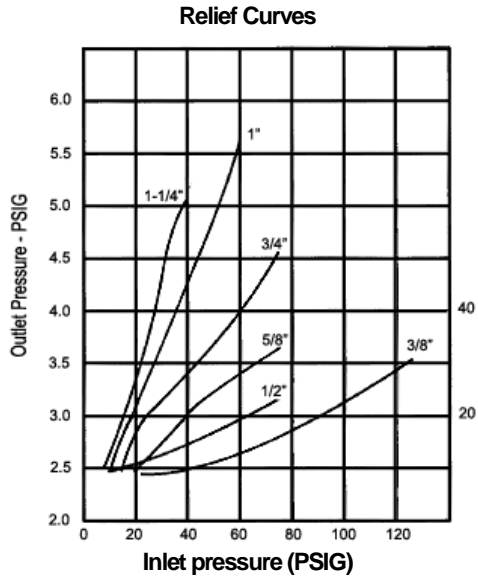

5 PSIG Set Point

Type and model B838
Inlet size 2" Flanged
Outlet size 4" Flanged
Orifice size 1-1/4"

All test results are reported at a base of 14.7 PSIG at 60° F and with 0.6 S.G. gas.

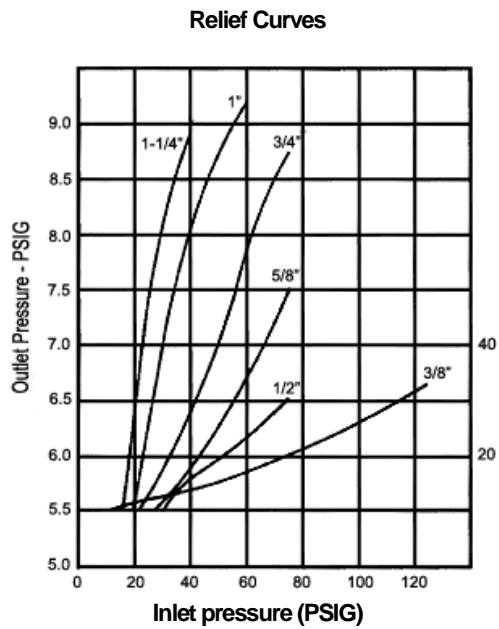

B-838 Monitor Specifications 2" x 2"

Orifice Size (inches)	Inlet Pressure PSIG	Capacity, SCFH								
		Drop in pressure across orifice, PSIG								
		0.1	0.2	0.3	0.4	0.5	1.0	2.0	3.0	5.0
1-1/4 K = 2925	1	3650	5100	6250	7200	8050				
	2	3750	5300	6450	7450	8300	11500			
	3	3850	5450	6650	7650	8550	11900	16300		
	5	4050	5750	7000	8100	9050	12600	17400	20700	
	8	4350	6200	7550	8700	9700	13600	18800	22400	27500
	10	4550	6450	7900	9100	10100	14200	19700	23500	29000
	15	5000	7100	8650	10000	11100	15600	21700	26100	32500
	25	5800	8200	10000	11500	12900	18100	25300	30600	38500
	35	6500	9200	11200	12900	14500	20400	28500	34600	43700
	50	7400	10500	12800	14800	16500	23300	32700	39700	50500
	75	8750	12300	15100	17400	19500	27500	38700	47100	60100
100	9900	13900	17100	19700	22000	31100	43900	53500	68500	
1 K = 2290	1	2850	4000	4900	5650	6300				
	2	2950	4150	5050	5800	3500	9050			
	3	3000	4250	5200	6000	6700	9350	12800		
	5	3200	4500	5500	6350	7050	9900	13600	16200	
	8	3400	4850	5900	6800	7600	10600	14700	17600	21500
	10	3550	5050	6150	7100	7950	11100	15400	18400	22700
	15	3900	5550	6800	7800	8750	12200	17000	20400	25400
	25	4550	6400	7850	9050	10100	14200	19800	24000	30100
	35	5100	7200	8800	10100	11300	15900	22300	27100	34200
	50	5800	8200	10000	11600	12900	18200	25600	31100	39500
	75	6850	9650	11800	13600	15200	21500	30300	36900	47100
100	7750	10900	13400	15400	17300	24400	34300	41900	53600	
3/4 K = 1640	1	2050	2875	3500	4050	4500				
	2	2100	2975	3600	4150	4650	6450			
	3	2150	3050	3700	4300	4800	6700	9150		
	5	2275	3200	3950	4550	5050	7050	9750	11600	
	8	2450	3450	4250	4850	5450	7600	10500	12600	15400
	10	2550	3600	4400	5100	5700	7950	11000	13200	16200
	15	2800	3950	4850	5600	6250	8750	12200	14600	18200
	25	3250	4600	5600	6500	7250	10200	14200	17200	21600
	35	3650	5150	6300	7250	7100	11400	16000	19400	24500
	50	4150	5850	7200	8300	9250	13000	18300	22300	28300
	75	4900	6900	8450	9800	10900	15400	21700	26400	33700
100	5550	7800	9600	11000	12300	17400	24600	30000	38400	

K-factors are wide open.

B-838 Monitor Specifications 2" x 3"

Orifice Size (inches)	Inlet Pressure PSIG	Capacity, SCFH								
		Drop in pressure across orifice, PSIG								
		0.1	0.2	0.3	0.4	0.5	1.0	2.0	3.0	5.0
1-1/4 K = 3400	1	4200	5950	7300	8400	9350				
	2	4350	6150	7500	8650	9650	13400			
	3	4500	6350	7750	8900	9950	13800	19000		
	5	4750	6700	8200	9400	10500	14700	20200	24000	
	8	5100	7200	8800	10100	11300	15800	21800	26100	31900
	10	5300	7500	9150	10600	11800	16500	22900	27400	33700
	15	5850	8250	10000	11600	12900	18200	25300	30400	37700
	25	6750	9550	11600	13400	15000	21100	29500	35600	44700
	35	7550	10600	13000	15000	16800	23700	33200	40200	50800
	50	8600	12200	14900	17200	19200	27100	36000	46200	58700
	75	10100	14300	17600	20300	22700	32000	45000	54800	69900
100	11500	16200	19900	22900	25600	36200	51000	62200	79600	
1 K = 2900	1	3600	5100	6200	7150	7950				
	2	3700	5250	6400	7400	8250	11400			
	3	3800	5400	6600	7600	8500	11800	16200		
	5	4050	5700	6950	8050	8950	12500	17200	20500	
	8	4350	6150	7500	8650	9650	13500	18600	22200	27200
	10	4500	6400	7600	9000	10000	14100	19500	23300	28700
	15	4950	7000	8600	9900	11000	15500	21500	25900	32200
	25	5750	8150	9950	11400	12800	18000	25100	30400	38100
	35	6450	9100	11100	12800	14300	20200	28300	34300	43300
	50	7350	10400	12700	14700	16400	23100	32400	39400	50100
	75	8650	12200	15000	17300	19300	27300	38400	46700	59600
100	9800	13800	16900	19600	21900	30900	43500	53000	67900	
3/4 K = 2000	1	2475	3500	4250	4900	5500				
	2	2575	3600	4400	5100	5650	7900			
	3	2650	3700	4550	5250	5850	8150	11200		
	5	2800	3900	4800	5650	6150	8600	11800	14100	
	8	3000	4200	5150	5950	6650	9300	12800	15300	18800
	10	3100	4400	5400	6200	6950	9700	13400	16100	19800
	15	3400	4850	5900	6800	7600	10700	14800	17800	22200
	25	3950	5600	6850	7900	8850	12400	17300	20900	26300
	35	4450	6250	7650	8850	9900	13900	19500	23600	29800
	50	5050	7150	8750	10100	11300	15900	22300	27200	34500
	75	5950	8450	10300	11900	13300	18800	26400	32200	41100
100	6750	9550	11700	13500	15100	21300	30000	36600	46800	

K-factors are wide open.

B-838 Monitor Specifications 2" x 4"

Orifice Size (inches)	Inlet Pressure PSIG	Capacity, SCFH								
		Drop in pressure across orifice, PSIG								
		0.1	0.2	0.3	0.4	0.5	1.0	2.0	3.0	5.0
1-1/4 K = 3500	1	4350	6150	7500	8650	9600				
	2	4500	6300	7750	8900	9900	13800			
	3	4600	6500	7950	9200	10200	14300	19600		
	5	4850	6900	8400	9700	10800	15100	20800	24700	
	8	5200	7400	9000	10400	11600	16300	22400	26800	32800
	10	5450	7700	9400	10900	12100	17000	23500	28100	34600
	15	6000	8450	10300	11900	13300	18700	26000	31200	38800
	25	6950	9800	12000	13800	15400	21700	30300	36600	45900
	35	7750	11000	13400	15500	17300	24400	34100	41300	52200
	50	8850	12500	15300	17700	19800	27900	39100	47500	60300
	75	10400	14700	18100	20900	23300	32100	46300	56300	71900
100	11800	16700	20500	23600	26400	37300	52500	63900	81800	
1 K = 3000	1	3700	5250	6400	7400	8250				
	2	3850	5400	6600	7600	8500	11800			
	3	3950	5600	6800	7850	8750	12200	16800		
	5	4150	5900	7200	8300	8250	12900	17800	21200	
	8	4500	6350	7750	8900	9950	13900	19250	23000	28100
	10	4650	6600	8100	9300	10400	14600	20200	24100	29700
	15	5150	7250	8900	10200	11400	16000	22300	26800	33200
	25	5950	8400	10300	11800	13200	18600	26000	31400	39400
	35	6650	9400	11500	13300	14800	20900	29200	35400	44800
	50	7600	10700	13100	15200	16900	23900	33500	40700	51700
	75	8950	12600	15500	17900	20000	28200	39700	48300	61600
100	10100	14300	17500	20200	22600	31900	45000	54800	70200	
3/4 K = 2100	1	2600	3650	4500	5150	5750				
	2	2700	3800	4650	5350	5950	8300			
	3	2750	3900	4750	5500	6150	8550	11700		
	5	2900	4100	5050	5800	6500	9050	12400	14800	
	8	3150	4450	5400	6250	6950	9750	13500	16100	19700
	10	3250	4600	5650	6500	7300	10200	14100	16900	20800
	15	3600	5050	6200	7150	8000	11200	15600	18700	23300
	25	4150	5900	7200	8300	9250	13000	18200	22000	27600
	35	4650	6600	8050	9300	10400	14600	20500	24800	31300
	50	5300	7500	9200	10600	11800	16700	23500	28500	36200
	75	6250	8850	10800	12500	14000	19700	27600	33800	43100
100	7100	10000	12300	14100	15800	22300	31400	38400	49100	

K-factors are wide open.

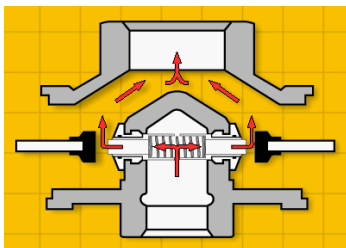

A. Normal regulation

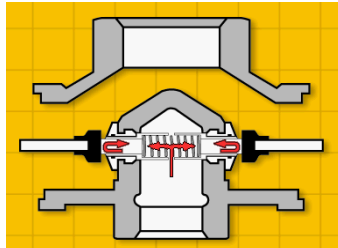

B. Normal lock-up

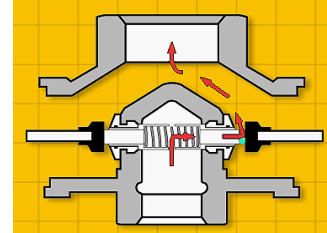

C. Dual monitor operation - internal foreign material failure

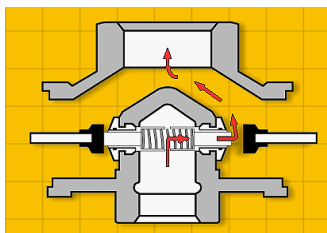

D. Single monitor operation - full internal diaphragm case failure

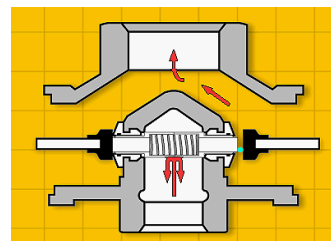

E. Total lock-up

Principle of Operation

A. Normal regulation. The internal monitor orifice operates like a standard one-piece orifice, performing normal regulation.

B. Normal lock-up. The regulator is free to lock-up in the usual manner. The O-ring seal prevents gas from leaking past the orifice exterior into the downstream or low pressure side of the valve body.

C. Dual monitor operation - internal foreign material failure. If the regulator fails to lock-up for any reason, the internal monitor orifice automatically goes into operation. Outlet pressure increases slightly, causing the valve seat to push against the inner or sliding part of the orifice gradually compressing the monitor spring and closing the secondary or monitor orifice on the inlet side of the sliding orifices. At this point, the B-838-IM functions as a monitor regulator. For example, assume a weld bead is caught between the orifice and the valve seat while the regulator is in high-flow operation. If the flow reduces, the valve tries to close but can't due to the foreign matter. The outlet pressure increases approximately 2" w.c. above the original set point which starts to close the secondary monitor orifice. If the gas demand is decreased, the monitor orifice will partially close and become the new operating orifice. The new orifice will function as a monitor regulator and keep the outlet pressure approximately 3" above the set pressure on inches water column, or .8 PSIG when set for PSIG outlet. If the flow becomes further reduced to no-flow, then the sliding orifice (or orifices) close against the secondary rubber seat providing a complete no-gas flow with a total outlet pressure build up of only 6" w.c. above the original set point.

D. Single monitor operation - one full internal diaphragm case failure. If the diaphragm case is damaged on one side of the piping such that the lever and valve seat cannot move to close against the orifice face, the outlet pressure builds (as described in C) on the good regulator and its sliding orifice moves to contact the non-movable failed orifice monitor seat. Closing or lock-up will be restricted according to flow demand. Since only one diaphragm is in operation, the outlet overpressure will be approximately 4" w.c. higher on single monitor operation than normal regulation set.

E. Total lock-up. If the demand for gas downstream of regulator is zero, the sliding orifice (or orifices) will close against the secondary rubber monitor seat and lock-up the gas flow completely.

B838-IMRV Flow Chart		
	Inlet pressure (PSIG)	Flow SCFH
Vented gas flow, regulator seat failed, monitor seat closed	20	60
	40	90
	60	120
	75	150
	100	190
	125	230

B838 IM Twin Parallel Flow Service Regulator

Capacity Table, 2" x 2"

Outlet Pressure		7" w.c.	7" w.c.	11" w.c.	11" w.c.	1 PSIG	2 PSIG	2 PSIG	2 PSIG	5 PSIG	5 PSIG	5 PSIG	
Pressure Droop		1" w.c.	1" w.c.	2" w.c.	2" w.c.	0.2 PSIG	1% ABS	2% ABS	WO	1% ABS	2% ABS	WO	
Orifice Size* (in inches)	Inlet Pressure PSIG	Flow rate, SCFH of .60 Wp. Gr. gas @ 14.7 PSIA and 60°F											
		0°	20°	0°		0°	0°	0°	0°	0°	0°	0°	
1	K = 1830	Loading Ring Setting											
		1	2600	2250	2750								
		2	3650	3400	4400		3900						
		3	5000	4850	5650		5200	2700	4200	7480			
		5	6200	6000	7500	N.C.	7450	4100	6500	12950			
		10	6750	9100	10300		10600	6200	10600	21140	3700	5600	18150
		15	11300	11000	13450		12700	8200	13600	26960	5000	7600	25670
		25	19000	17800	20000		19300	14750	17800	36330	7100	11000	36330
30	-	20000	20000		20000	18100	20000	40900	9800	14200	40900		
3/4	K = 1400	Loading Ring Setting											
		1	2150	1900	2300	2000							
		2	3400	3050	3650	3400	3300						
		3	4000	3750	4600	4250	4300	2300	3500	5720			
		5	5700	5100	6250	6000	5800	3400	5400	9910			
		10	8000	7250	9600	9450	8950	5500	8600	16170	3600	5400	13890
		15	10200	9000	11500	11000	11400	6600	10600	20620	4700	7200	19640
		25	16850	15700	17700	16900	17600	10400	15600	27800	6900	9600	27800
60	-	20000	-	20000	20000	20000	20000	52290	13100	18700	52290		
5/8	K = 1095	Loading Ring Setting											
		1	1750	1700	2000	1950							
		2	3600	2500	3200	3150	2750						
		3	3400	3200	4200	4050	3800	1800	2650	4480			
		5	5200	4800	5900	5650	5300	2750	4150	7750			
		10	7500	6900	9400	8750	8250	4500	7200	12650	3100	4500	10860
		15	9900	8800	11000	10050	10550	6200	9600	16130	4000	5900	15360
		25	15600	15200	16000	14900	15100	10300	14200	21570	6100	9200	21570
60	-	20000	-	2000	20000	17800	20000	40900	12500	17800	40900		
1/2	K = 790	Loading Ring Setting											
		1	1600	1550	1500	1450							
		2	2300	2250	2300	2250	2350						
		3	2900	2850	2900	2800	3050	1650	2300	3230			
		5	3800	3700	4050	3900	4150	2650	3500	5590			
		10	6600	5250	6500	5900	6600	4000	6300	9130	2600	3200	7840
		15	8100	6650	8500	7300	8500	5900	8000	11640	3600	4900	11080
		25	10900	8650	11900	10000	12000	9600	12600	15680	5300	7400	15680
		60	-	15900	-	19100	19500	16800	20000	29510	9400	14400	29510
		90	-	20000	-	20000	20000	20000	20000	41360	13700	18350	41360
125	-	20000	-	20000	20000	20000	20000	55180	190000	20000	55180		

* Both orifices wide open
 N.C. No change needed in loading ring setting.

B838 IM Twin Parallel Flow Service Regulator

Capacity Table, 2" x 2" continued

Outlet Pressure		7" w.c.	7" w.c.	11" w.c.	11" w.c.	1 PSIG	2 PSIG	2 PSIG	2 PSIG	5 PSIG	5 PSIG	5 PSIG
Pressure Droop		1" w.c.	1" w.c.	2" w.c.	2" w.c.	0.2 PSIG	1% ABS	2% ABS	WO	1% ABS	2% ABS	WO
Orifice Size* (in inches)	Inlet Pressure PSIG	Flow rate, SCFH of .60 Wp. Gr. gas @ 14.7 PSIA and 60°F										
		0°	27°	0°	25°	0°	0°	0°	0°	0°	0°	0°
Loading Ring Setting		0°	27°	0°	25°	0°	0°	0°	0°	0°	0°	0°
3/8 K = 600	1	1000	950	1200	1050							
	2	1700	1650	1950	1800	1700						
	3	2200	2150	2400	2300	2200	1300	1800	2800			
	5	3100	2900	3200	3100	3000	2000	2750	4250			
	10	4800	4400	5000	4600	4500	3200	4350	6930	2050	2650	5950
	15	6600	5600	6600	5800	5700	4000	6050	8840	2700	3550	8420
	25	10000	4800	10000	8200	8400	5050	8600	11910	3400	4800	11910
	60	17000	14000	17500	14400	17000	12000	17000	22410	6200	10200	22410
	90	-	18100	-	18400	20000	16300	20000	31410	7200	12400	31410
125	-	20000	-	20000	20000	20000	20000	41910	11300	18800	41910	

* Both orifices wide open

N.C. No change needed in loading ring setting.

B838 IM Twin Parallel Flow Service Regulator

Capacity Table, 2" x 3"

Outlet Pressure		7" w.c.	7" w.c.	11" w.c.	11" w.c.	1 PSIG	2 PSIG	2 PSIG	2 PSIG	5 PSIG	5 PSIG	5 PSIG		
Pressure Drop		1" w.c.	1" w.c.	2" w.c.	2" w.c.	0.2 PSIG	1% ABS	2% ABS	WO	1% ABS	2% ABS	WO		
Orifice Size* (in inches)	Inlet Pressure PSIG	Flow rate, SCFH of .60 Wp. Gr. gas @ 14.7 PSIA and 60°F												
Loading Ring Setting		0°		0°		0°	0°	0°	0°	0°	0°	0°		
1	1	2700		2900										
	2	4300		4500		4000								
	3	5650		6450		5700	3200	4900	7765					
	5	7400	N.C.	8750	N.C.	8100	5400	7800	13450					
	10	15300		14900		13100	8800	12700	20945	4500	6700	18150		
	15	19600		19500		16800	11800	17000	27985	6160	9400	26655		
	25	27000		27100		26400	16800	25000	37715	9400	14200	37715		
	30	32000		32000		31700	22000	30000	42465	10100	16200	42465		
Loading Ring Setting		0°		40°			36°	0°	0°	0°	0°	0°		0°
3/4	1	2500		2300			2550							
	2	3700		3100			4100	3300						
	3	4900	3850		5100	4400	2750	4100	5885					
	5	7000	5700	N.C.	7050	6250	3700	5800	10190					
	10	10650	8700		10600	10400	6600	9900	16630	3700	5600	14285		
	15	313800	11800		14200	13500	8200	12700	21210	5000	7600	20205		
	25	-	18000		21000	20900	15000	20900	28585	7100	10500	28585		
	60	-	36000		36300	36300	34000	40000	53785	15500	24800	53785		
Loading Ring Setting		0°	38°		0°	34°	0°	0°	0°	0°	0°		0°	
5/8	1	1850	1800		2250	2100								
	2	3100	2600		3400	3300	2750							
	3	4000	3550	4400	4300	3800	2300	3500	4660					
	5	5700	4900	6000	5800	5300	3300	4800	8070					
	10	9400	7450	9450	9100	8250	4900	7800	13165	3200	4600	11310		
	15	12500	9300	12500	11650	19550	6800	10600	16790	4100	6000	15995		
	25	20000	17500	19700	19200	16100	10500	16300	22630	6200	9300	22630		
	60	-	35200	-	36100	35400	28700	34000	42850	13500	19600	42580		

* Both orifices are wide open

N.C. No change needed in loading ring setting.

B838 IM Twin Parallel Flow Service Regulator

Capacity Table, 2" x 3" continued

Outlet Pressure		7" w.c.	7" w.c.	11" w.c.	11" w.c.	1 PSIG	2 PSIG	2 PSIG	2 PSIG	5 PSIG	5 PSIG	5 PSIG	
Pressure Droop		1" w.c.	1" w.c.	2" w.c.	2" w.c.	0.2 PSIG	1% ABS	2% ABS	WO	1% ABS	2% ABS	WO	
Orifice Size* (in inches)	Inlet Pressure PSIG	Flow rate, SCFH of .60 Wp. Gr. gas @ 14.7 PSIA and 60°F											
		Loading Ring Setting											
		0°	34°	0°	34°	0°	0°	0°	0°	0°	0°	0°	
1/2	K = 800	1	1600	1550	1500	1450							
		2	2300	2250	2300	2250	2350						
		3	2900	2850	3000	2800	3050	1650	2300	3470			
		5	4000	3700	4400	3900	4150	2650	3500	5660			
		10	6800	5850	6950	3650	6600	4000	6300	9240	3600	3200	7935
		15	8500	6750	9000	7900	8500	5900	8000	11785	3700	4900	11225
		25	14100	11400	13400	11600	12000	9600	12600	15880	5300	7400	15880
		60	-	25700	-	25700	25700	20600	24000	29880	9400	14400	29880
		90	-	34800	-	34800	34800	28000	33300	41880	13700	21300	41880
		125	-	40000	-	40000	40000	35800	40000	55880	20200	29100	55880
Loading Ring Setting		0°	32°	0°		0°	0°	0°	0°	0°	0°	0°	
3/8	K = 600	1	1000	950	1200								
		2	1700	1650	1950		1700						
		3	2200	2150	2400		2200	1450	1850	2800			
		5	3100	2900	3200		3000	2150	2850	4250			
		10	4950	4400	5000	N.C.	4550	3500	4400	6930	2050	2650	5950
		15	6600	5600	6600		5850	4200	6100	8840	2700	3550	8420
		25	10400	8900	10300		8850	6400	8800	11910	3450	4900	11910
		60	21050	19200	21000		18800	14300	18200	22410	6800	10600	22410
		90	-	27000	28200		26800	23200	26400	31410	10900	16800	31410
		125	-	34000	35000		33000	29100	33200	41910	14200	22500	41910

* Both orifices are wide open

N.C. No change needed in loading ring setting.

B838 IM Twin Parallel Flow Service Regulator

Capacity Table, 2" x 4"

Outlet Pressure		7" w.c.	7" w.c.	11" w.c.	11" w.c.	1 PSIG	2 PSIG	2 PSIG	2 PSIG	5 PSIG	5 PSIG	5 PSIG	
Pressure Droop		1" w.c.	1" w.c.	2" w.c.	2" w.c.	0.2 PSIG	1% ABS	2% ABS	WO	1% ABS	2% ABS	WO	
Orifice Size* (in inches)	Inlet Pressure PSIG	Flow rate, SCFH of .60 Wp. Gr. gas @ 14.7 PSIA and 60°F											
Loading Ring Setting		0°	25°	0°		0°	0°	0°	0°	0°	0°	0°	
1	1	2900	2800	2900	N.C.								
	2	4600	4400	4550		4500							
	3	6500	6250	6700		5900	3300	5000	7970				
	5	9700	9000	9100		8550	5450	7900	13800				
	10	16700	16100	16250		13800	8950	12900	22525	4650	6900	19345	
	15	22000	21000	21600		18000	12400	17700	28725	6300	9700	27360	
	25	31000	29800	31000		30300	20000	27300	38710	9700	14650	38710	
	30	-	36000	37000		36100	24400	33000	43585	10400	16700	43585	
Loading Ring Setting		0°	25°	0°	27°	0°	0°	0°	0°	0°	0°	0°	
3/4	1	2700	2450		2850								
	2	4350	4250		4500	3450							
	3	5500	4950		6100	4600	2850	4200	6200				
	5	8200	7500	N.C.	8300	6500	3800	6100	10475				
	10	13900	11400		13950	10650	6900	10500	17095	3800	5800	14680	
	15	-	16900		18100	14500	8500	13700	21800	5150	7850	20765	
	25	-	26200		28000	23200	1500	21200	29380	7350	10800	29380	
	60	-	48000		50000	46100	39700	47500	55280	16000	27800	55280	
Loading Ring Setting		0°			0°		0°	0°	0°	0°	0°	0°	0°
5/8	1	2200			2300	N.C.							
	2	3300			3500		3000						
	3	4200		4450	3900		2500	3400	4800				
	5	6100	N.C.	6300	5450		3900	5400	8315				
	10	10100		10500	8600		5200	8000	13570	3300	4750	11655	
	15	13850		13500	11200		6900	10800	17310	4250	6200	16485	
	25	21500		21500	17400		11500	17200	23325	6400	9600	23325	
	60	40000		40000	39200		30000	36200	43885	13900	21000	43885	
Loading Ring Setting		0°		40°	0°		0°	0°	0°	0°	0°	0°	0°
1/2	1	1850		1600	1800	N.C.							
	2	2600		2450	2850		2400						
	3	3350	3100	3500	3200		1750	2550	3700				
	5	4500	4150	5000	4250		3000	3900	5735				
	10	7450	6750	7400	6700		4500	6400	9355	2650	3300	8035	
	15	9600	8550	9950	8600		6000	8200	11930	3800	5050	11365	
	25	14700	14400	14500	12450		9800	13000	16080	5450	7600	16080	
	60	-	23600	33000	29400		22200	27800	30255	9700	14850	30255	
	90	-	39800	40100	37900		35000	37000	42405	14100	21950	42405	
	125	-	51200	52300	51500		45500	51000	56580	21000	30100	56580	

* Both orifices are wide open
 N.C. No change needed in loading ring setting.

B838 IM Twin Parallel Flow Service Regulator

Capacity Table, 2" x 4" continued

Outlet Pressure		7" w.c.	7" w.c.	11" w.c.	11" w.c.	1 PSIG	2 PSIG	2 PSIG	2 PSIG	5 PSIG	5 PSIG	5 PSIG
Pressure Droop		1" w.c.	1" w.c.	2" w.c.	2" w.c.	0.2 PSIG	1% ABS	2% ABS	WO	1% ABS	2% ABS	WO
Orifice Size* (in inches)	Inlet Pressure PSIG	Flow rate, SCFH of .60 Wp. Gr. gas @ 14.7 PSIA and 60°F										
		Loading Ring Setting										
		0°		0°		0°	0°	0°	0°	0°	0°	0°
3/8 K = 600	1	1100		1200								
	2	1750		2150		2000						
	3	2300		3750		2400	1650	2150	2800			
	5	3150		3200		3250	2300	3400	4250			
	10	5050	N.C.	5100	N.C.	4850	3600	4500	6930	2050	2650	5950
	15	6700		6700		6400	4300	6250	8840	2700	3550	8420
	25	10600		10300		9050	6550	9000	11910	3450	4900	11910
	60	22200		22000		20700	14500	18400	22410	6800	10600	22410
	90	30500		30400		29300	25600	28300	31400	10900	16800	31400
125	35100		34900		35200	30000	34000	41910	14200	22500	41910	

* Both orifices are wide open

N.C. No change needed in loading ring setting.

B838 IMR Performance Curves

7" w.c. Set Point

Type and model	B838 IMR
Inlet size	2" NPT
Outlet size	2" NPT
Orifice size	3/4"
Spring range	Green/white
Position	Horizontal

All test results are reported at a base of 14.7 PSIG at 60° F and with 0.6 S.G. gas.

Performance Curves

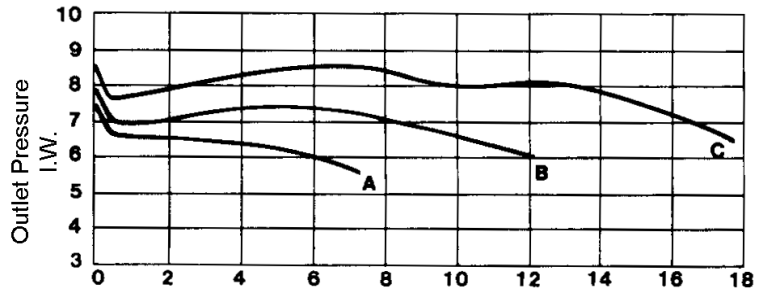

2 PSIG Set Point

Type and model	B838 IMR
Inlet size	2" NPT
Outlet size	2" NPT
Vent size	

All test results are reported at a base of 14.7 PSIG at 60° F and with 0.6 S.G. gas.

Performance Curves

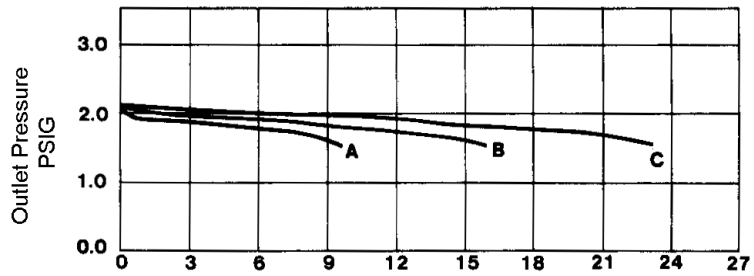

5 PSIG Set Point

Type and model	B838 IMR
Inlet size	2" NPT
Outlet size	2" NPT
Orifice size	3/4"
Spring range	Red
Position	Horizontal

All test results are reported at a base of 14.7 PSIG at 60° F and with 0.6 S.G. gas.

Performance Curves

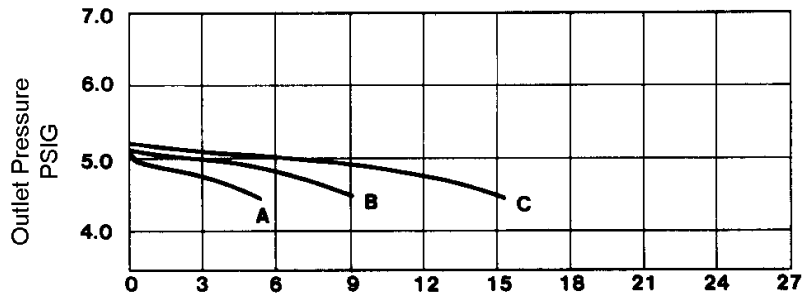

B838 IMR Monitor Curves

7" w.c. Set Point¹

Type and model	B838 IMR
Inlet size	2" NPT
Outlet size	2" NPT
Inlet pressure	20 PSIG @ set
Orifice size	5/8"
Spring range	Green/White
Position	A
Loading ring set @ 27°	

Monitor Curves²

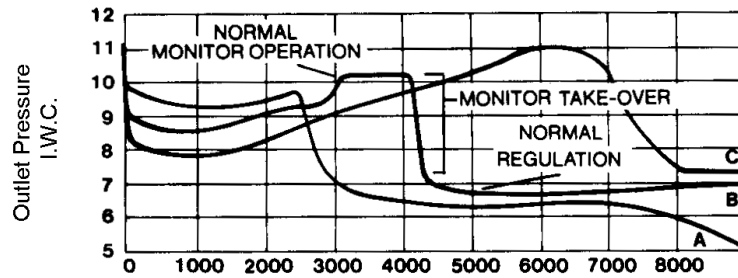

Curves:

- A 10 PSIG - W.O.R.
- B 20 PSIG - SET
- C 40 PSIG - W.O.R.

2 PSIG Set Point¹

Type and model	B838 IMR
Inlet size	2" NPT
Outlet size	2" NPT
Inlet pressure	20 PSIG @ set
Orifice size	5/8"
Spring range	Silver
Position	A
Loading ring set @ 0°	

Monitor Curves²

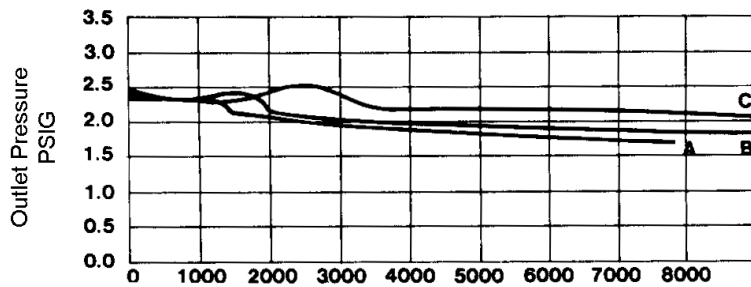

Curves:

- A 10 PSIG - W.O.R.
- B 20 PSIG - SET
- C 40 PSIG - W.O.R.

5 PSIG Set Point¹

Type and model	B838 IMR
Inlet size	2" NPT
Outlet size	2" NPT
Inlet pressure	20 PSIG @ set
Orifice size	5/8"
Spring range	Red
Position	A
Loading ring set @ 0°	

Monitor Curves²

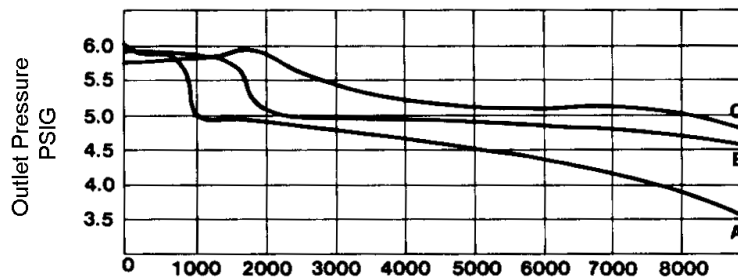

Curves:

- A 10 PSIG - W.O.R.
- B 20 PSIG - SET
- C 40 PSIG - W.O.R.

¹ .125 diameter rod glued to one valve seat.

² One regulator blocked wide open.

B838 IMR Relief Valve Characteristics¹

7" w.c. Set Point

Relief Valve Characteristics¹

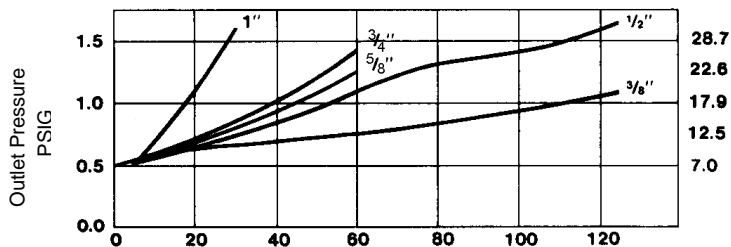

2 PSIG Set Point

Relief Valve Characteristics¹

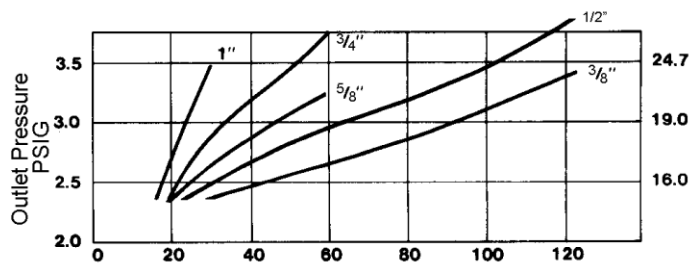

5 PSIG Set Point

Relief Valve Characteristics¹

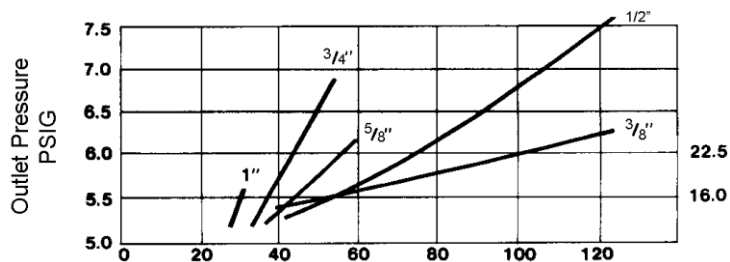

Vented flow - SCFH x 1000

Inlet Pressure - PSIG

¹ One valve seat blocked wide open per orifice size and foreign particle wedged between monitor sealing surfaces.

Assembly Positions

The six basic assembly positions are shown here.

Please specify the required position by letter designation when ordering.

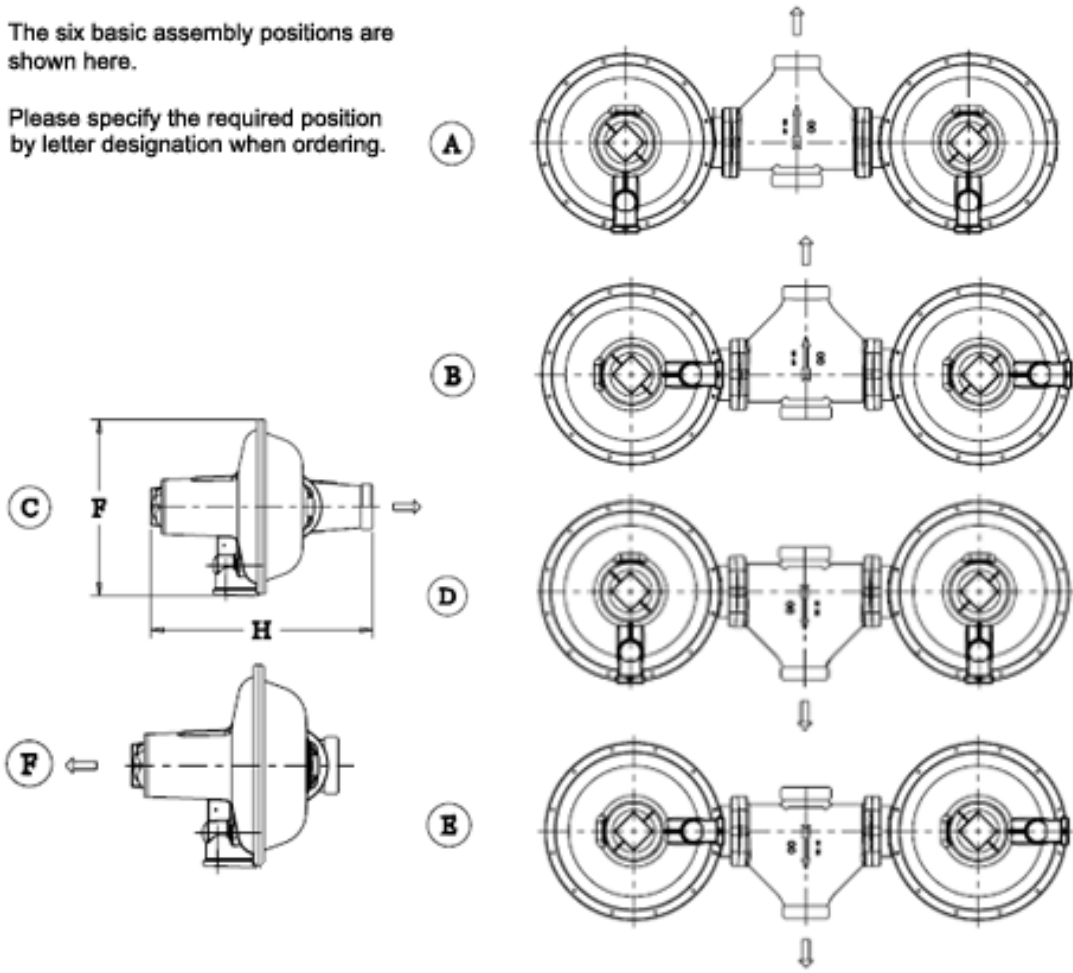

Parts List

B838 R Twin Parallel Flow Regulator

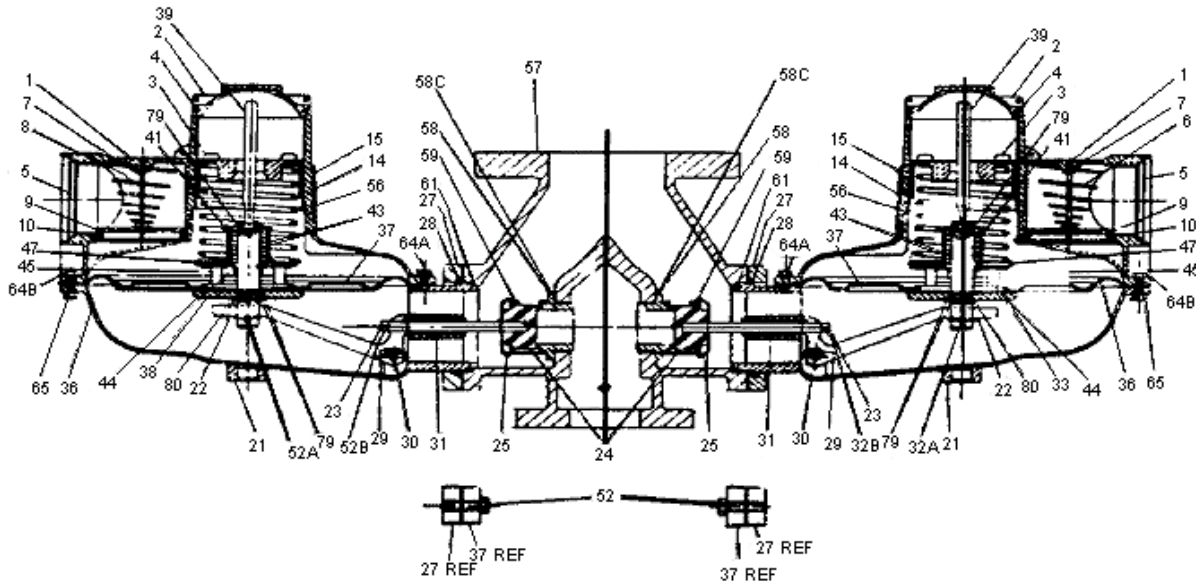

B838 N Twin Parallel Flow Regulator

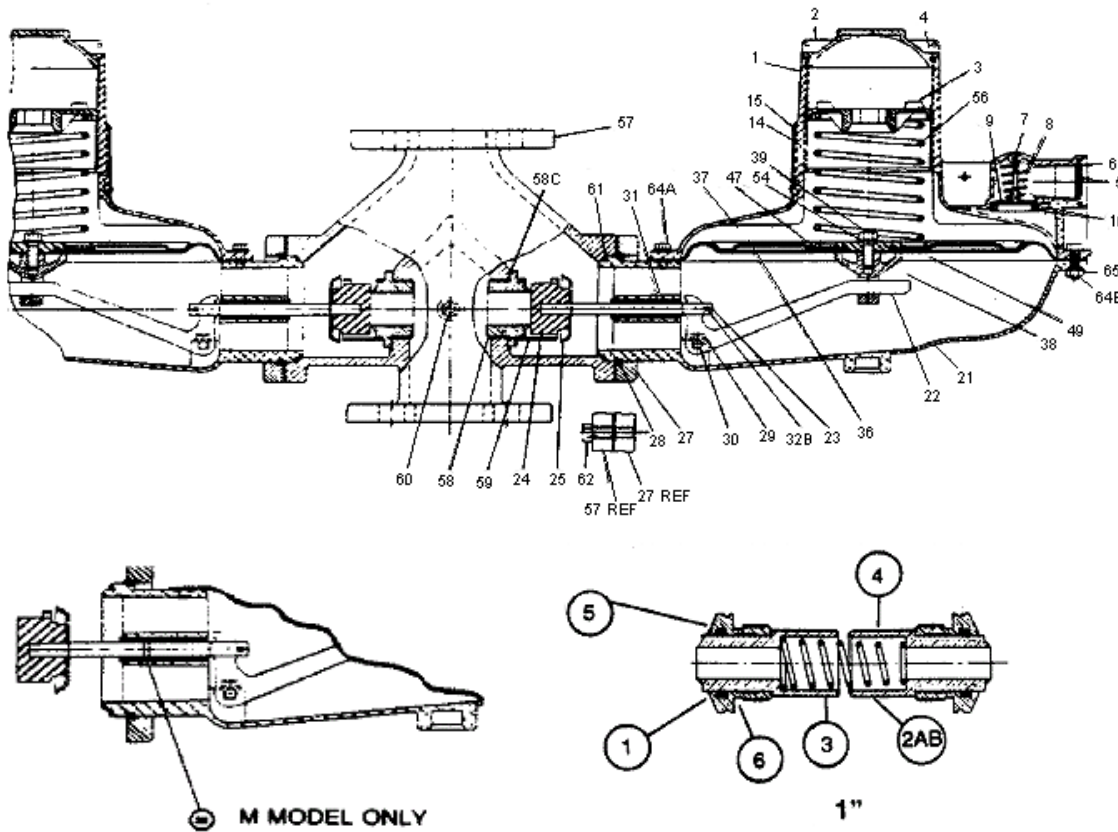

Item No.	Part No.	Quantity Required per Regulator Model						Description
		RD	RM	D	M	R	N	
1	753404	-	-	2	2	-	2	Upper diaphragm case – vent – 1" pipe
1A	753434	2	2	-	-	2	-	Upper diaphragm case – vent – 2-1/2" pipe
2	760083	2	2	2	2	2	2	Seal cap
3	760233	-	-	2	2	-	2	Adjustment screw
3A	760253							Adjustment screw
4	765607							Seal cap gasket
5	762933							Vent screen – 1" vent
5A	762941							Vent screen – 2-1/2" vent
6	75579101							Vent screen retainer ring – 1" vent
7	75483401							Vent valve disc pin - 1" vent
7A	754801							Vent valve disc pin – 2-1/2" vent
8	762601							Vent valve spring – 1" vent
8A	80000601							Vent valve spring – 2-1/2" vent
9	765181							Vent valve disc - 1" vent
9A	765343							Vent valve disc – 2-1/2"
10	765685							Vent valve seat – 1" vent
10A	761651							Vent valve seat – 2-1/2" vent
14	769241							Regulator badge
	769245							Regulator badge - IM
15	755071							Badge drive screw
21								Lower diaphragm case
	715065							4:1 ratio - open throat
	715066							3.5:1 ratio – closed throat
22								Valve linkage lever
	761275							4:1 ratio standard
	761271							3.5:1 ratio
23								Valve stem
	754191							3/8" square
	754193							17/32" diamond without ring groove
24	765211							Valve seal -Buna N – 80 Durometer
25	761731							Deflector
27	751933							Valve body retainer plate
28	755721							Retainer - snap ring
29	755223							Valve linkage pin screw
30	754836							Valve linkage pin
33	765505							Valve stem O-ring
36	766321							Diaphragm – relief
	766301							Diaphragm – no relief
37	761091							Upper diaphragm plate
	76104101							Upper diaphragm plate
38								Lower diaphragm plate
	756075							No bead
	756081							With bead

Item No.	Part No.	Quantity Required per Regulator Model						Description
		RD	RM	D	M	R	N	
39	755363							Stop Stem
	754385							Stop stem sub - assembly - self aligning
	754381							Lower
	754383							Upper
	755739							Retaining ring (lower stem)
	765171							Disc (rubber)
41	761455							Relief spring guide
43	762401							Relief spring brown - standard
	762403							Relief spring - green
44	754941							Stop stem guide bushing
45	761671							Relief cap
47	761481							Adjustment spring guide
	761483							Adjustment spring guide
	755001							Roll pin - stop stem
	755007							3/32 diameter x 3/8 length
	755009							3/32 diameter x 1/2 length
54	755851							Diaphragm plate washer - lock
56		2	2	2	2	2	2	Adjustment spring - specify
	762351							Brown
	762353							Green
	762355							Black
	762357							Blue
	762358							Blue/white
	762359							Silver
	762361							Yellow
	762671							Red (nested)
	762673							White (nested)
	762321							Green/White stripe
	762323							Silver/Red
	762341							Orange
	762345							Orange/Green
	762365							Purple
57		1	1	1	1	1	1	Valve body - specify type and size:
								Straight
	750954							2 X 2 NPT
	750959							2 x 2 NPT with 1/8" NPT pipe plug
57								Flanged
	750965							2 x 2" ASA 10" face to face
	750969							2 x 2" ASA with 1/8 NPT pipe plug
	750974							2 x 3" ASA 10" face to face
	750975							2 x 3" ASA with 1/8 NPT pipe plug
	750984							2 x 4" ASA 10" face to face
	750985							2 x 4" ASA with 1/8 NPT pipe plug
	750989							2 x 4" ASA with 1/4 NPT outlet tap

Item No.	Part No.	Quantity Required per Regulator Model						Description	
		RD	RM	D	M	R	N		
58		2	2	2	2	2	2	Orifice - specify type and size: Straight - Brass - 2 ¹ A" II ext	
	758371							.320 X 3/8	
	758372							1/4 X 3/8	
	758398							1/4	
	758401							1/2	
	758404							3/4	
	758407							1", B38/838 CL38/838"	
	758410							1-1/4	
	758413							1-3/8	
	758416							5/8	
	758419							3/8	
								IM Orifice Assemblies – See Internal Monitor	
59	761771	2	2	2	2	2	2	Loading ring	
60								Valve body pipe plug	
	768443	See item #57 for required quantity							1/8 NPT - steel
	764431							1/8 NPT - stainless steel	
61	80001901	2	2	2	2	2	2	Valve body gasket	
62	755391	4	4	4	4	4	4	Retainer plate screw - 3/8 - 16 X 1 - 5/16 hex head	
62A	755393	4	4	4	4	4	4	Retainer plate screw 3/8 16 X 1 5/16 hex head -	
64B	755307	24	24	24	24	24	24	Case screw - hex head - 1 20 x 1" length steel	
65	755513	20	20	20	20	20	20	Case screw nut	
79	755711	6	6	-	-	6	-	Stop stem retainer ring - external	
80	766521	2	2	-	-	2	-	O-ring lower diaphragm	
91	765525	2	2	2	2	2	2	Orifice O-ring	
								Subassemblies	
	710040	-	-	2	2	-	2	Upper diaphragm case - 1" vent, subassembly	
	710045	2	2	-	-	2	-	upper diaphragm case - 2 1/2 vent, subassembly	
	715030	-	-	-	-	2	2	Lower diaphragm case subassembly	
								Lower diaphragm case subassembly 3:5:1 ratio -	
	715031	-	2	-	2	-	-	With valve stem O-ring	
	715064	2	-	2	-	-	-	Without valve stem O-ring	
	720029	-	-	2	2	-	2	Diaphragm subassembly - no relief	
	720033	2	2	-	-	2	-	Diaphragm subassembly - relief – standard	
	720034	2	2	-	-	2	-	Diaphragm subassembly - relief – green relief	

Internal Monitor Orifice Assembly Parts Lists

3/8" and 1/2" Orifice Components

Item No.	Description	Part No.
1	Stationary orifice	758437
2A	3/8" Sliding orifice (male)	758471
2B	3/8" Sliding orifice with vent hole (male)	758474
2A	1/2" sliding orifice (male)	758477
2B	1/2" Sliding orifice with vent hole (male)	758480
3	3/8" Sliding orifice (female)	759151
3	1/2" Sliding orifice (female)	759153
4	Cut - off spring (red)	762451
5	O-ring	765531
6	O-ring	765525

Note: components are interchangeable.

5/8" and 3/4" Orifice Components

Item No.	Description	Part No.
1	Stationary orifice	758434
2A	5/8" Sliding orifice (male)	758484
2B	5/8" Sliding orifice with vent hole (male)	758487
2A	3/4" Sliding orifice (male)	758490
2B	3/4" Sliding orifice with vent hole (male)	758493
3	5/8" Sliding orifice (female)	759155
3	3/4" Sliding orifice (female)	759157
4	Cut - off spring (blue)	762453
5	O-ring	765533
6	O-ring	765525

Note: components are interchangeable.

1" Orifice Components

Item No.	Description	Part No.
1	Stationary orifice	758431
2A	1" Sliding orifice (male)	758497
2B	1" Sliding orifice w vent hole (male)	758498
3	1" Sliding orifice (female)	759159
4	Cut - off spring (yellow)	762455
5	O-ring	765523
6	O-ring	765525

IMN and IMR Orifice Assembly - Complete

Item No.	Description	Part No.
58A	3/4" diameter	759161
	3/4" diameter	759165
	3/4" diameter	759171
	3/4" diameter	759175
	1" diameter	759181

IMRV Orifice Assembly - Complete

Item	Description	Part No.
58B	3/4" diameter	759163
	1/2" diameter	759167
	3/4" diameter	759173
	3/4" diameter	759177
	1" diameter	759183

Note: 1" components are not interchangeable with other sizes.

Special Tools

Description	Part No.
Machined orifice wrench	799027
Adjustment wrench	799055
Seal wire, no lead, 24	80002002

Notes:

- B838 IMN parts are identical to B838N parts except for the orifice assembly.
- B838 IMR parts are identical to B838R parts except for the orifice assembly.
- B838 IMRV parts are identical to B838R parts except for the orifice assembly.

Torque Specifications

Retainer Plate Screws	100 in. lbs.
Orifice	600 in. lbs.
Orifice (IM)	300 in. lbs.
Margin screws (item no.648)	50 in. lbs.
Margin screws (item no. 64A)	30 in. lbs.

Vent Lines for Regulators

When constructing vent lines to be attached to regulators installed indoors, follow a few basic rules:

- a. Never use pipe sizes smaller than the vent size; smaller pipe sizes restrict the gas flow. If a long gas run must be used, Itron advises increasing the pipe one nominal size every ten feet to keep the flow restriction as low as possible.
- b. Keep the vent line length as short as possible to minimize the restriction and reduce the vent's tendency to cause regulator pulsation.
- c. Support the vent pipe to eliminate strain on the regulator diaphragm case.
- d. Always point outdoor vent pipes in the downward position to reduce the possibility of rain, snow, sleet, and other moisture entering the pipe. Install a bug screen in the end of the pipe.
- e. Do not locate the vent line terminus near windows, fans, or other ventilation equipment. See the installation instructions furnished with the regulator.
- f. Adhere to all applicable codes and regulations.
- g. If your vent pipe causes regulator pulsation, consult your sales representative or manufacturer.
- h. Itron strongly recommends running a separate vent line for each regulator. Headers with various installed devices can cause regulator malfunction.

Caution Ensure the end of the vent line is away from ANY potential ignition sources. It is the installer's responsibility to ensure the vent line is exhausting to a safe environment.

Installation

Warning Itron does not endorse or warrant the completeness or accuracy of any third party regulator installation procedures or practices, unless otherwise provided in writing by Itron. Follow your company's standard operating procedures regarding the use of personal protection equipment (PPE). Adhere to guidelines issued by your company in addition to those given in this document when installing regulators.

- a. Remove all shipping plugs from the regulator inlet, outlet, and vent before installation.
- b. Verify the piping interior and regulator inlet and outlet are clean and free of dirt, pipe dope, and other debris. Dirt and other foreign materials entering the regulator can cause a loss of pressure control.
- c. Apply pipe joint sealant to the male pipe threads. Do not use pipe joint material on the regulator's female threads. Joint sealant could become lodged in the regulator and cause a loss of pressure control.
- d. Gas must flow through the regulator's valve body in the direction cast on the regulator body. Gas flowing in the wrong direction can overpressure and cause damage to the regulator.
- e. The diaphragm casing can be mounted in any position relative to the body through a full 360° angle at 90° increments.
- f. When the regulator is installed OUTDOORS, the vent must always be positioned so that rain, snow, moisture or foreign particles cannot enter the vent opening. Itron recommends positioning the vent downward to avoid entry of water or other matter which could interfere with the proper operation of the regulator. The vent should be located away from building eaves, window openings, building air intakes and above the expected snow level at the site. The vent opening should be inspected periodically to insure it does not become blocked by foreign material as outlined in DOT PHMSA-RSPA-2004-19856.
- g. When the regulator is installed INDOORS, the vent must be piped to the outside atmosphere using the shortest length of pipe, the fewest possible pipe elbows, and a pipe diameter as large as the vent size or larger. USING VENT PIPE SMALLER THAN THE VENT CONNECTION LIMITS THE REGULATOR'S INTERNAL RELIEF VALVE CAPACITY. The outlet end of the pipe must be protected from moisture and the entrance of foreign particles. The regulator should be specified by the user with the size vent and pipe threads desired to make the vent pipe connection.

Start-up and Adjustment

Warning The seal caps for the main diaphragm cases must always be installed and wrench tight before introducing gas flow to the regulator and for as long as gas pressure is present in the regulator.

- a. Mount a pressure gauge downstream of the regulator to monitor the downstream pressure.
 - b. With the downstream pressure valve closed, slowly open the inlet valve. The outlet pressure should rise to slightly more than the set-point. Verify there are no leaks and all connections are tight.
 - c. The regulator was pre-set at the factory to match order specifications. If regulator readjustments are necessary, the adjustment is made to the springs only. While the regulator is under steady flow conditions of 500 cfh or more, remove the regulator seal caps.
-

Caution Never remove or loosen main diaphragm case seal caps while gas is present, under pressure, in the regulator.

- d. To increase outlet pressure, turn each adjustment screw clockwise in equal increments until the outlet pressure is about 10% below desired gauge pressure. Adjust one screw clockwise to desired outlet pressure. Turn the second screw clockwise until a slight increase in outlet pressure is observed. Make slight counter-clockwise adjustments to achieve the desired outlet pressure. Both springs should always be set at the same pressure to keep both valves operating in unison.
- e. To decrease outlet pressure, turn each adjustment screw counterclockwise in equal increments until the outlet pressure is about 10% below desired outlet pressure. Adjust one screw clockwise to desired outlet pressure. Turn the second screw clockwise until a slight increase in outlet pressure is observed. Make slight counter-clockwise adjustments to achieve the desired outlet pressure. Both adjustment screws should always be set at the same pressure to keep both valves operating in unison.
- f. Replace the seal cap and check for leaks after the desired outlet pressure is achieved.

The regulator is ready for operation.

Safety Warning

This product, as of the date of manufacture, is designed and tested to conform to all governmental and industry safety standards as they may apply to the manufacturer. The purchaser/user of this product must comply with all fire control, building codes, and other safety regulations governing the application, installation, operation, and general use of this regulator to avoid leaking gas hazards resulting from improper installation, startup or use of this product.

Itron strongly recommends installation by a qualified professional and periodic inspection of pressure regulators (inspections may be required by local applicable codes or regulations).

Inspections should include checking for gas quality, cycle numbers, external environmental changes, and operating conditions that impact wear on the regulator's moving parts. To ensure safe and efficient operation of this product, replace worn or damaged parts found during inspection.

Limited Warranty

Itron, Inc. 970 Highway 127 North, Owenton, Kentucky 40359-9302, warrants this gas product against defects in materials and workmanship for the earlier of one (1) year from the date the product is shipped by Itron or a period of one year from the date the product is installed by Itron at the original purchaser's site. During such one-year period, provided that the original purchaser continues to own the product, Itron will, at its sole option, repair any defects, replace the product or repay the purchase price.

- > This warranty will be void if the purchaser fails to observe the procedures for installation, operation or service of the product as set forth in the Operating Manual and Specifications for the product or if the defect is caused by tampering, physical abuse or misuse of the product.
- > ITRON SPECIFICALLY DISCLAIMS ALL IMPLIED WARRANTIES INCLUDING THOSE OF MERCHANTABILITY OR OF FITNESS FOR A PARTICULAR PURPOSE. UNDER NO CIRCUMSTANCES WILL ITRON BE LIABLE FOR INCIDENTAL OR CONSEQUENTIAL DAMAGES OF ANY KIND WHATSOEVER.
- > Itron's liability for any claim of any kind, including negligence and breach of warranty for the sale and use of any product covered by or furnished, shall in no case exceed the price allocable to the product or part thereof which gives rise to the claim.

- > In the event of a malfunction of the product, consult your Itron Service Representative or Itron Inc., 970 Highway 127 North, Owenton, Kentucky 40359-9302. See Itron Terms and Conditions of Sale for the full and complete terms of the Limited Warranty.

Ordering Information

Specify:

1. Inlet and Outlet Connection Size and Type
2. Model Number
3. Outlet pressure desired
4. Pilot needed
5. Inlet pressure range
6. Type of gas and maximum capacity required
7. Assembly position number (see chart below)
8. Special requirements such as tagging, 1/8" pipe plug tap, seal wire, etc.

About Itron Inc.

At Itron, we're dedicated to delivering end-to-end smart grid and smart distribution solutions to electric, gas and water utilities around the globe. Our company is the world's leading provider of smart metering, data collection and utility software systems, with nearly 8,000 utilities worldwide relying on our technology to optimize the delivery and use of energy and water. Our offerings include electricity, gas, water and heat meters; network communication technology; collection systems and related software applications; and professional services. To realize your smarter energy and water future, start here: www.itron.com



Itron Gas

970 Highway 127 North
Owenton, Kentucky 40359
USA
Phone: 1.800.490.0657
1.502.484.5747
fax: 1.502.484.6223

Corporate Headquarters

2111 North Molter Road
Liberty Lake, WA 99019
USA
Phone: 1.800.635.5461
Fax: 1.509.891.3355
www.itron.com