



B35 Series Regulator

Field Service Regulator

- ▶ Economical
- ▶ Diaphragm case disassembles from valve body for easy inspection and maintenance
- ▶ Internal relief valve allows avoidance of costly external relief valves
- ▶ No special start-up procedures required
- ▶ Easy-to-replace valve seat design
- ▶ No special tools required for outlet pressure adjustment
- ▶ No minimum differential pressure requirement

Features

- Built-in internal relief valve
- Inlet Pressures up to 1000 PSIG
- Outlet Pressure range of 5-150 PSIG
- Conforms with ANSI B31.8 code
- Field interchangeable orifice
- Polyurethane seat ensures reliable "lock-up" (up to 1000 PSIG inlet pressure)
- Designed to withstand several times the maximum recommended operating pressures
- Corrosion resistant
- 3/4" and 1" valve bodies available in threaded
- 14 different assembly positions
- Relief indicator visible from long distance



Applications

The B35 is specially designed for safe, accurate first-stage pressure reduction on high-pressure gas systems. It is a versatile pounds-to-pounds unit which is ideal for high-pressure industrial applications, rural and suburban taps.

Description

With a malleable iron body, the B35 will handle inlet pressures up to 1000 PSIG. Outlet pressures range from 10 to 150 PSIG. Seven different orifices are available from 1/16" through 1/2" in either brass or stainless steel. They are interchangeable in all valve body sizes.

▶ B35R

When properly sized, the B35R can be used for multi-regulator cuts with complete safety on installations up to 1000 PSIG inlet with reductions up to 150 PSIG and ultimately to 7" W.C. outlet* without an external relief valve and will conform to the ANSI B31.8 code.

▶ B35N

Standard field service regulator. Used primarily where internal relief is not required. Has Breather Vent in upper diaphragm case - 1/4" N.P.T. with stainless steel screen and complete water drain position.

▶ B35M

Special B35 unit with sealed throat and downstream control tap. Used in series monitoring installations as an operating safety device that assumes control over the operating regulator when a failure is sensed by the downstream control line.

Relief Valve Characteristics

Integral internal relief is an exclusive feature in this type of regulator. The lever assembly is zinc plated steel with built in safety stops for proper operation of the relief valve in event of mechanical failure of other parts.

The relief valve is separated from the diaphragm clamping and maintains a guided, position alignment with the "O" ring seat. Combines large throat opening, relief valve and vent area which provides quick passage of gas to relief area and large relief flow.

Correction factors for non-natural gas applications:

The B35 may be used to control materials other than natural gas. To determine the capacity of the B35 for gases other than natural gas, it will be necessary to multiply the values within the capacity tables by a correction factor.

The table below lists the correction factors for some of the more common gases:

Gas Type	Specific Gravity	Correction Factor (CF)
Air	1.00	0.77
Butane	2.01	0.55
Carbon Dioxide (Dry)	1.52	0.63
Carbon Monoxide (Dry)	0.97	0.79
Natural Gas	0.60	1.00
Nitrogen	0.97	0.79
Propane	1.53	0.63
Propane-Air-Mix	1.20	0.71

To calculate the correction factor for gases not listed on the table above, it will be necessary to know the specific gravity of the gas and use it in the formula listed below:

$$\text{Correction Factor (CF)} = \sqrt{\frac{SG_1}{SG_2}}$$

Where:

SG_1 = Specific Gravity of the gas in which the capacity is published.

SG_2 = Specific Gravity of the gas to be controlled.

Construction

Material Construction:

Valve Body:	Ductile Iron or Steel
Orifice:	Brass (standard); Stainless Steel (Optional)
Valve Seat:	Polyurethane or nylon
Valve Stem:	Plated steel
Valve Stem bushing:	Brass
Lever Pin:	Stainless steel (Type 303)
Lever:	Zinc and dichromate plated steel
Upper Diaphragm Plate:	Zinc and dichromate plated steel
Lower Diaphragm Plate:	Zinc and dichromate plated steel
Diaphragm:	Buna-N and nylon reinforcing fabric
Vent Screen:	Stainless Steel
Adjustment Ferrule:	Plated Steel
Seal Cap:	Cast Iron
Diaphragm Case:	Ductile Iron
Diaphragm Case Screws:	Steel (Torx head) -Optional Stainless Steel with socket head

Shipping Weight:

6 Regulators per box: 80 lbs. per box

Operator and Monitor Installation

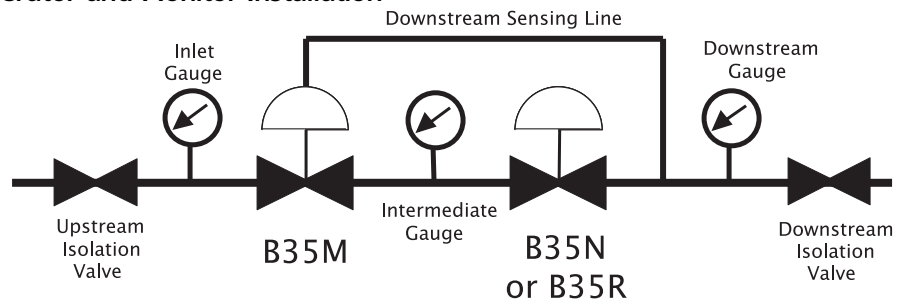

Specifications

Valve Body Sizes

Connection Type	
Body Size (inches)	Ductile Iron Body
3/4" or 1"	NPT thread
Maximum Capacity:	35,000 scfh (see capacity tables)
Available Vent Sizes:	R models - 3/4" (threaded NPT optional) N&M models - 1/4" NPT
Operating Temperature Range:	-20 F to 150 F*
Other Available Options:	-Seal wire to indicate tampering -1/8" pipe plug tap on upstream side of valve body -1/4" or 1/8" NPT tap on diaphragm case (for outlet pressure measurement)

Spring Data

	Spring Color	Outlet Pressure Range**
Standard Spring Data - B35	Green	5 - 8
	Orange	8 - 15
	Green/White	15 - 25
	Blue/White	25 - 45
	Silver	40 - 75
	Yellow	70 - 100

**Note: Ranges are approximations, please contact manufacture to obtain the best spring for application.

Orifice Data

Orifice Size	K-Factor	Maximum Operating Inlet Pressure (PSIG)	Maximum Emergency Inlet Pressure (PSIG)	Maximum Emergency Outlet Pressure (No Damage) (PSIG)	Maximum Emergency Outlet Pressure (Gas Containment) (PSIG)
1/16" x 3/32	8.9	1000 (DI Body)	1200 (DI Body)	150 PSIG + Outlet Pressure Set Point	1000
3/32"	17.5				
1/8"	30.0				
3/16"	71.0				
1/4"	127.0				
3/8"	290.0				

Wide-Open Flow Calculations

For wide-open orifice flow calculations use the following equations:

For $P_1/P_2 < 1.89$ use: $Q = K \sqrt{P_2 (P_1 - P_2)}$ For $P_1/P_2 > 1.89$ use: $Q = \frac{KP_1}{2}$

Where: P_1 = absolute inlet pressure (psia) P_2 = absolute outlet pressure (psia)
 Q = flow rate (scfh) K = orifice coefficient (scfh/psia)

Inlet Pressure Effect

Spring Color	Change in Inlet Pressure to Change Outlet Pressure by 1 PSIG					
	Orifice Size					
	3/32"	1/8"	3/16"	1/4"	3/8"	1/2"
Green	400	220	140	70	50	20
Orange	380	220	130	70	40	20
Green/White	380	220	130	70	40	20
Blue/White	340	170	100	60	30	20
Silver	250	160	100	60	30	20
Yellow	220	140	90	60	30	20
Red	140	100	70	40	30	20

► B35R Dimensions

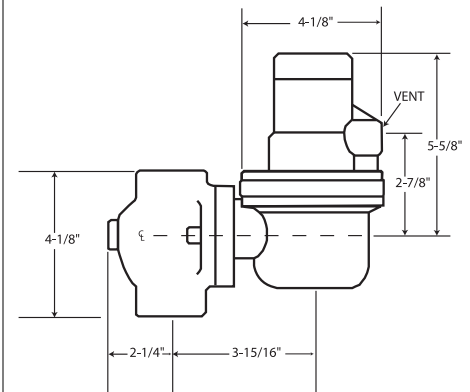

► Spring Data

Main Spring Color	Change in Inlet Pressure to Change Outlet Pressure 1 PSIG					
	Orifice Size					
	3/32	1/8	3/16	1/4	3/8	1/2
Green	400	220	140	70	50	20
Orange	380	220	130	70	40	20
Green & White	380	220	130	70	40	20
Blue & White	340	170	100	60	30	20
Silver	250	160	100	60	30	20
Yellow	220	140	90	60	30	20
Red	140	100	70	40	30	20

Seal Caps - 3 Types

1. Cast Iron - Internal Relief Valve Type
 (used on B35R) - No vent pipe attachment. Contains stainless steel spiral vent screen plated steel guide - vent down for complete water drain. In this model, a red indicator ball stays out after Relief Valve has functioned. Indicator ball is reset manually.

2. Cast Iron - Internal Relief Valve Type
 (used on B35R) - For 3/4" vent pipe attachment. Similar to Cap 1, above, with 3/4" N.P.T. vent tap and without spiral vent or indicator ball.

3. No Relief Type (For B35N) - Solid cap.

B35 Field Service Regulator

Spring Ranges*

Use spring data table to obtain actual spring ranges for inlet pressures not listed.

Adjusted Outlet Pressure Range Spring Adjustment Ferrule at Minimum and Maximum Depths				
Spring Color	Orifice Size	Inlet Pressure	Outlet Pressure	
			Minimum	Maximum
Green	3/32	200 PSI	1	6
	1/8	200 PSI	1	7
	3/16	200 PSI	2	8
	1/4	200 PSI	3	9
	3/8	200 PSI	5	11
	1/2	200 PSI	10	17
Orange	3/32	200 PSI	7	14
	1/8	200 PSI	7	14
	3/16	200 PSI	8	16
	1/4	200 PSI	9	16
	3/8	200 PSI	12	20
	1/2	200 PSI	18	24
Green and White	3/32	200 PSI	12	23
	1/8	200 PSI	12	23
	3/16	200 PSI	13	24
	1/4	200 PSI	14	24
	3/8	200 PSI	16	27
	1/2	200 PSI	22	31
Blue and White	3/32	500 PSI	22	42
	1/8	500 PSI	23	44
	3/16	500 PSI	25	46
	1/4	500 PSI	28	48
	3/8	300 PSI	28	48
	1/2	200 PSI	29	49
Silver	3/32	500 PSI	15	74
	1/8	500 PSI	16	76
	3/16	500 PSI	18	78
	1/4	500 PSI	20	80
	3/8	300 PSI	21	79
	1/2	200 PSI	23	79
Yellow	3/32	500 PSI	13	99
	1/8	500 PSI	14	100
	3/16	500 PSI	17	103
	1/4	500 PSI	19	104
	3/8	300 PSI	19	102
	1/2	200 PSI	20	102
Red	3/32	500 PSI	5	153
	1/8	500 PSI	7	155
	3/16	500 PSI	9	158
	1/4	500 PSI	12	158
	3/8	300 PSI	12	154
	1/2	200 PSI	13	152

* Minimum ferrule depth = 0.350
Maximum ferrule depth = 1.065

B35 Field Service Regulator - Models R, N, M

Capacity Data (20% Gauge Droop)*

(Capacities in scfh (cubic meters/hr) of 0.6 S.G. Gas; Base Condition: 14.7 psia & 60F)

Inlet Pressure PSIG	Outlet Pressure PSIG	1/16" x 3/32"	3/32"	1/8"	3/16"	1/4"	3/8"	1/2"
15	10	95 (2.7)	190 (5.4)	330 (9.3)	780 (22.1)	1350 (38.2)	3500 (99.2)	3400 (96.3)
20	10	140 (4.0)	270 (7.6)	470 (13.3)	1100 (31.2)	1900 (53.8)	3400 (96.3)	4800 (136.0)
	15	105 (3.0)	210 (5.9)	360 (10.2)	850 (24.1)	1450 (41.1.0)	2700 (76.5)	3700 (104.8)
30	11 or less	200 (5.7)	390 (11.0)	670 (19.0)	1550 (43.9)	2700 (76.5)	4900 (138.8)	6900 (195.5)
	15	185 (5.2)	360 (10.2)	630 (17.8)	1450 (41.1)	2500 (70.8)	4600 (130.3)	6600 (187.0)
	20	165 (4.7)	320 (9.1)	550 (15.6)	1300 (36.8)	2200 (62.3)	4100 (116.1)	5700 (161.5)
50	22 or less	285 (8.1)	565 (16.0)	970 (27.5)	2300 (65.2)	3900 (110.5)	7000 (198.3)	10000 (283.3)
	25	275 (7.8)	550 (15.6)	930 (26.3)	2220 (62.9)	3700 (104.8)	6900 (195.5)	9700 (274.8)
	40	205 (5.8)	410 (11.6)	700 (19.8)	1650 (46.7)	2800 (79.3)	5100 (144.5)	7100 (116.1)
75	37 or less	395 (11.2)	780 (22.1)	1300 (36.8)	3100 (87.8)	5300 (150.1)	9800 (277.6)	14000 (396.6)
	50	360 (10.2)	710 (20.1)	1200 (34.0)	2800 (79.3)	4800 (136.0)	9000 (255.0)	12500 (354.1)
	60	295 (8.4)	580 (16.4)	1000 (28.3)	2300 (65.2)	4000 (113.3)	7600 (215.3)	10200 (289.0)
100	50 or less	500 (14.2)	1000 (28.3)	1700 (48.2)	4000 (113.3)	6900 (195.5)	12700(359.8)	17800 (504.2)
	60	485 (13.7)	950 (26.9)	1600 (45.3)	3800 (107.6)	6500 (184.1)	12000(339.9)	17000 (481.6)
	75	420 (11.9)	820 (23.2)	1400 (39.7)	3300 (93.5)	5700 (161.5)	10500(297.5)	14500 (410.8)
150	68 or less	730 (20.7)	1400 (39.7)	2400 (68.0)	5800 (164.3)	10000(283.3)	18300(518.4)	25000 (708.2)
	75	700 (19.8)	1400 (39.7)	2400 (68.0)	5700 (161.5)	9800 (277.6)	18000(509.9)	24500 (694.1)
	100	670 (19.0)	1300 (36.8)	2200 (62.3)	5300 (150.1)	9100 (257.8)	20000(566.6)	23000 (651.6)
200	90 or less	950 (26.9)	1850 (52.4)	3200 (90.7)	7500 (212.5)	13000(368.3)	23000(651.6)	33000 (934.8)
	100	900 (25.5)	1800 (51.0)	3100 (87.8)	7400 (209.6)	12000(339.9)	22000(623.2)	32000 (906.5)
	150	800 (22.7)	1550 (43.9)	2700 (76.5)	6400 (181.3)	11000(311.6)	20000(566.6)	28000 (793.2)
300	140 or less	1350 (38.2)	2700 (76.5)	4700 (133.1)	11200(317.3)	19000(538.2)	35000(991.5)	Inlet Pressure Exceeds Orifice Rating
	150	1300 (36.8)	2600 (73.7)	4600 (130.3)	11000(311.6)	18500(524.1)	34000(963.2)	
400	150 or less	1800 (51.0)	3600 (102.0)	6200 (175.6)	14500(410.8)	25000(524.1)		
500	150 or less	2250 (63.7)	4300 (121.8)	7700 (218.1)	18200(515.6)	31000(708.2)		
600	150 or less	2700 (76.5)	5300 (150.1)	9200 (260.6)	21800(617.6)	37000(878.2)		
700	150 or less	3150 (89.2)	6200 (175.6)	10500(297.5)	25000 (708.2)			
800	150 or less	3600 (102.0)	7200 (204.0)	12000(339.9)	28600(810.2)			
1000	150 or less	4500 (127.5)	8800 (249.3)	15000(424.9)	36000 (1019.8)			

*Individual regulator performance may vary from data shown

Relief Pressure Data*

Spring Color	Outlet Pressure Set Point	Maximum Outlet Pressure	Maximum Inlet Pressure to stay below Max. Outlet Pressure					
			Orifice Size					
			1/16" x 3/32"	3/32"	1/8"	3/16"	1/4"	3/8"
Green	5 - 10	60	1000	770	435	190	100	63
	5 - 10	125	1000	1000	1000	490	285	175
Orange	15	60	1000	690	400	180	100	63
	15	125	1000	1000	1000	490	280	175
Green/White	20	60	1000	590	345	150	95	62
	20	125	1000	1000	1000	490	280	175
Blue/White	30	60	1000	570	310	130	90	62
	40	75	1000	610	360	160	110	90
	40	125	1000	1000	890	420	270	160
Silver	30	60	1000	550	300	120	75	62
	40	60	770	385	215	90	70	62
	40	75	1000	610	360	140	95	80
	50	90	1000	800	460	195	115	105
	60	100	1000	840	485	200	120	110
	75	125	1000	1000	580	225	145	132
Yellow	30 - 60	125	1000	1000	820	340	180	133
	50	100	1000	840	485	197	115	110
	50	150	1000	1000	970	400	231	166
	60	100	1000	830	475	193	115	110
	60	150	1000	1000	920	380	220	160
	75	125	1000	1000	580	225	145	132
	75	185	1000	1000	1000	490	285	200
	100	150	1000	1000	650	270	185	157
Red	100	225	1000	1000	1000	500	320	240
	75	175	1000	1000	800	300	220	184
	100	200	1000	1000	900	350	250	210
	120	250	1000	1000	1000	480	315	263
	150	285	1000	1000	1000	500	350	300

* Table body is the maximum inlet pressure that will allow the outlet pressure to stay below the value in the "Maximum Outlet Pressure" column during a wide-open failure situation.

Point of Relief Differential Pressure Data

Orifice Diff. Pressure PSIG	Outlet Pressure PSIG - w/o Spring					
	Orifice Size - Inches					
	3/32 ⁽¹⁾	1/8	3/16	1/4	3/8	1/2
50	.5	1.0	1.5	1.5	2.0	4.0
100	.5	1.0	1.5	2.0	2.5	7.5
200	1.0	1.5	2.5	3.5	5.0	12.5
300	2.0	2.5	4.0	5.5	8.0	20.0
400	3.0	3.5	5.5	7.5	11.5	-
500	3.5	4.5	7.5	9.5	15.0	-
600	4.0	5.5	9.5	12.0	19.0	-
700	4.5	6.5	11.5	14.5	-	-
800	5.0	7.5	14.0	17.0	-	-
900	5.5	8.0	16.0	19.5	-	-
1000	6.0	9.0	18.0	-	-	-

Point Of Relief - B35R

Relief Valve Spring = 14 PSIG less outlet pressure without adjusting spring. Add the remaining relief valve spring power to the adjusted outlet pressure. (Example: 400 PSI Inlet to 100 PSI Outlet, 1/4" orifice. 400-100=300 PSI differential pressure from above chart - 300 PSI 1/4" orifice gives 5.5 PSI Outlet. 14-5.5=8.5 PSI when added to 100 PSI Outlet Pressure, point of relief is 108.5 PSIG).

⁽¹⁾ Use the 3/32" orifice data for the 1/16" x 3/32" orifice.
 B35R Recommended maximum differential pressure above heavy line.
 B35N Recommended maximum differential pressure, as listed.
 Malleable Iron Valve Body - ASTM A197 - 1000 PSI.

Principle of Operation (See Operating Schematic)

The B35 is a Spring-Loaded Regulator designed for simple and reliable operation. Inlet pressure (dark shaded area) enters the valve body and flows through the orifice, across the valve seat, and into the Outlet Pressure chamber (light shaded area).

Increasing Load - As demand for gas increases downstream, the outlet pressure (light shaded area) decreases which allows the main spring force to overcome the outlet pressure force acting over the diaphragm area. This allows the diaphragm to reposition downward which moves the lever downward and opens the main valve. Diaphragm travel stops when the force of the adjustment spring equals the opposing outlet pressure force acting on the diaphragm.

Decreasing Load - As demand for gas decreases downstream, the outlet pressure (light shaded area) increases which allows the outlet pressure force acting over the diaphragm area to overcome the force of the adjustment spring. This allows the diaphragm to reposition upward which moves the lever upward and closes the main valve. Diaphragm travel stops when the force of the adjustment spring equals the opposing outlet pressure force acting on the diaphragm.

Regulator Field Relief Valve Test - (Cap Assembly)

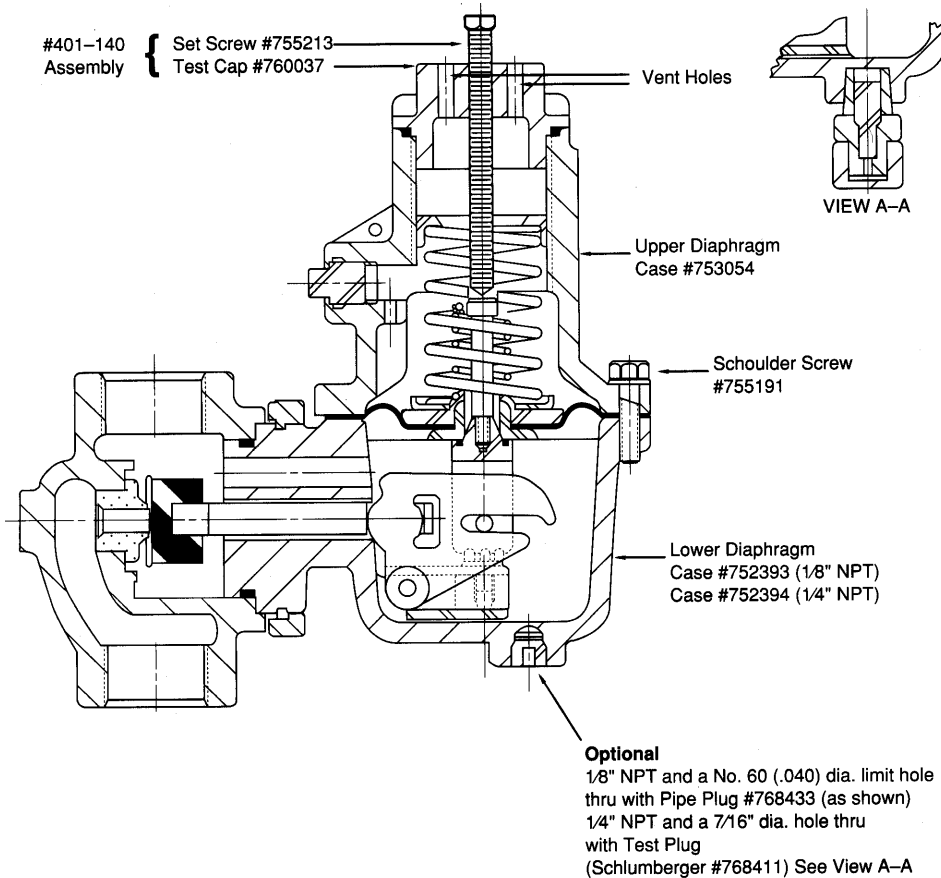

B35 Operating Schematic

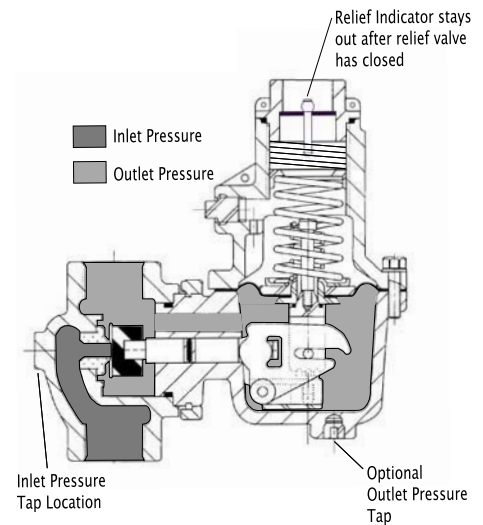

Instructions

1. Lower Diaphragm Case
 - a.) Supplied with a 1/8" Pipe Plug - Remove Pipe Plug, fasten Pressure Gauge to Boss.
 - b.) Supplied with a 1/4" Universal Seal Test Plug - Remove closing Cap on Plug, insert Gauge with Needle exposed, fasten Pressure Gauge to Plug.
2. Remove Vent cap from Upper Diaphragm Case and insert Special Test Cap (Assembly # 799073)
3. Screw Adjustment Set Screw clockwise until contact is made with Relief Valve Shoulder Screw.
4. Turn clockwise until small volume of gas relieves from vent holes.
5. Read Pressure Gauge for point of relief.
6. Turn Screw counterclockwise until resealed.
7. Check vent holes with soapy water.

B35N

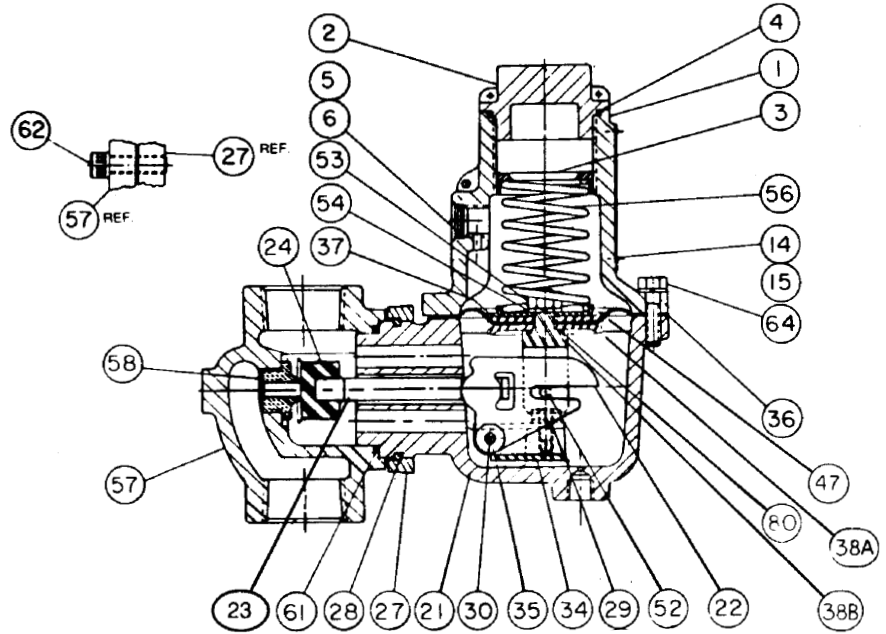

B35M

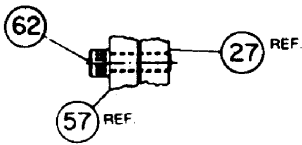

B35R

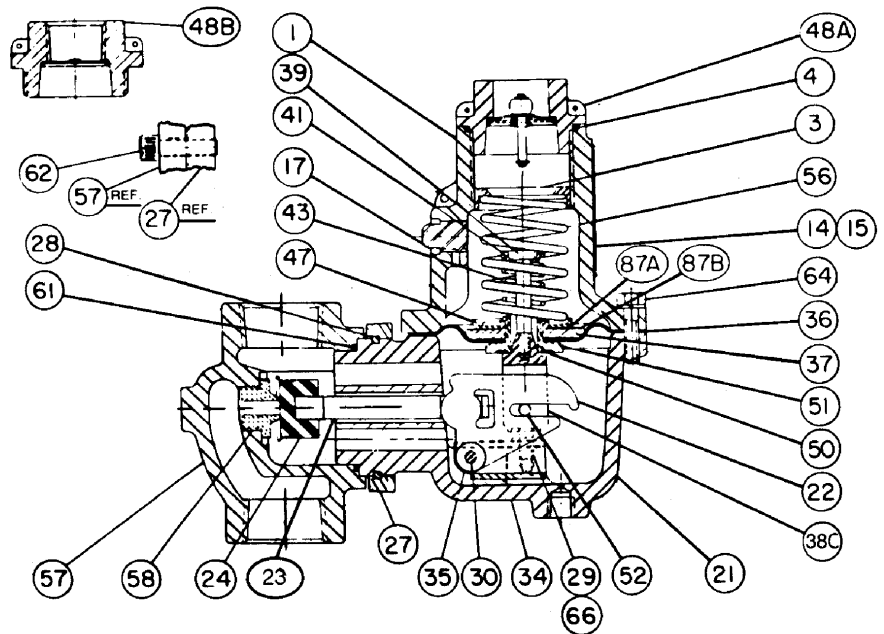

Torque Specifications

Retainer Plate Screws	85 - 115 in. lbs.
Orifice Cartridge	450 - 500 in. lbs.
Margin Screws	50 - 80 in. lbs.

Parts

NO.	PART#	QTY			DESCRIPTION
		N	R	M	
1					Upper Diaphragm Case - Specify
	753064	1	1	1	Vent - 1/4" Pipe
	710042	1	1		Upper Diaph. Case w/items 5 & 6
	710043			1	Upper Diaph. case w/item 17
2	760035	1	1		Seal Cap
3	760201	1	1	1	Adjustment Screw
4	765603	1	1	1	Seal Cap Gasket
5	762911	1	1		Vent Screen - Wire Mesh
6	755773	1	1		Vent Screen Ret. Ring
14	769241	1	1	1	Regulator Badge
15	755071	2	2	2	Badge Drive Screw
17	768421			1	Upper Diaph. case Pipe Plug-1/4-18 NPT
21				1	Lower Diaph. Case - Specify
	752034				Not Tapped
	752037				1/8 NPT Pipe Plug for 768431
	752040				1/4 NPT Pipe Plug for 768435 for 1/4 NPT Test Plug (R Model only) 768411
	752043	1			Closed Throat (M Model only)
22	761226			1	Valve Linkage Lever
	761221	1	1		Valve Linkage Lever
23	754061			1	Valve Stem - Steel - Specify
	754064			1	Valve Stem - Stainless Steel - Specify
	754071			1	Valve Stem - Stainless Steel
24	765235	1	1	1	Valve Seat Assy. - Urethane 95A - Duro
27	751953	1	1	1	Valve Body Ret. Plate
28	755725	1	1	1	Retainer Plate Snap Ring
29	755301	2	2	2	Valve Linkage Pin Screw Hex Head - 1/4-20x3/8 Lg. - Steel
30	754841	1	1	1	Valve Linkage Pin
31	754201			1	Valve Stem Bushing
32	754081			1	Valve Stem Adapter
33	765527			1	Valve Stem O-ring
34	761901	1	1	1	Lever Pin Retainer
35	755803	2	2	2	Lever Pin Washer
36					Diaphragm - Specify
	766021	1	1		5/16 I.D.
	766023			1	Diaphragm, 5/8 I.D.
37					Upper Diaphragm Plate
	761015	1	1		Upper Diaphragm Plate B35N
	761011			1	Upper Diaphragm Plate B35R
					Lower Diaphragm Plate
38A	756005	1	1		Diaphragm Plate Screw B36R
38B	756031	1	1		Lower Diaphragm Plate B35M & N
38C	756035			1	Lower Diaphragm Plate B35R
39	755191			1	Stop Stem
41	761411			1	Relief Spring Guide
43	762085			1	Relief Spring
47					Adjustment Spring Guide
	761431	1	1		Diaphragm Plate Spring Guide B35N
	761421			1	Diaphragm Plate Spring Guide B35R

NO.	PART#	QTY			DESCRIPTION
		N	R	M	
48				1	Vent Cap Assembly - Specify
A	730002				Non-Piped with Ball Indicator
B	730001				Piped
50	765711			1	Internal Relief Valve Seal Gasket-Buna "N"
51	756005			1	Diaphragm Plate Screw
52	755001	1	1		Rollpin - 3/16 D.x3/4 Lg. - Steel
53	755531	1	1		Diaphragm Nut - Hex 5/16-18 - Steel
54	755851	1	1		Diaph. Plate Split Lockwasher for 5/16-18-Steel
56				1	Adjustment Spring - Specify Color
	762403				Green
	762415				Orange
	762417				Green/White
	762419				Blue/White
	762409				Silver
	762411				Yellow
	762413				Red
57				1	Valve Body - Specify Size
	750504				3/4 x 3/4 NPT
	750507				3/4 x 1 NPT
	750510				1 x 1 NPT
58				1	Orifice - Specify Size
	757081				1/16x3/32 D. - Stn. Stl.
	757082				3/32 D. Stn. Stl.
	758531				1/8 D. - Brass
	758541				- Stainless Steel
	758532				3/16 D. Brass
	758542				- Stainless Steel
	758533				1/4 D. - Brass
	758543				- Stainless Steel
	758535				3/8 D. - Brass
	758545				- Stainless Steel
	758536				1/2 D. - Brass
	758546				- Stainless Steel
61	765605	1	1	1	Valve Body Gasket - Buna "N"
62				2	Retainer Plate Screw Soc. Hd. Cap Scw.-
	755171				5/16-18x1" Lg. - Steel
	755173				5/16-18x1" Lg. - Stainless Steel
64				8	Case Screw
	755205				Torx Hd. 1/4-20x1" Lg. Steel
	755180				Allen Hd. 1/4-20x1" Lg. Stn. Stl
66	755853				Valve Linkage Pin Screw Lockwasher
87A	755821			1	Anti-Friction Washer
87B	755823			1	Anti-Friction Washer
	PART#				Special Tools
					Test Assembly-Field Use-"Special Tool" (For checking point of relief)
	799073				Relief Valve Test Cap Assembly
	760049				Vent Protector for N
	720031				R Diaphragm Assembly
	720030				M&N Diaphragm Assembly

Installation

SAFETY NOTES:

- ▶ **A.** The maximum inlet pressure for this regulator is dependent upon the size of the orifice and model designation. The non-relief models are limited to 60 PSIG maximum inlet pressure unless additional safety devices are used as outlined in DOT code, OPS, Part 192, section 192.197.
- ▶ **B.** When these models are used on liquid petroleum gases, they should be restricted to second-stage pressure reduction in the gaseous phase.

- ▶ **A.** Make certain all shipping plugs are removed from the inlet, outlet and vent of any regulator before installation.
- ▶ **B.** When installing the regulator, the inside of the piping and the regulator inlet and outlet are to be clean, free of dirt, pipe dope and other debris to prevent entry into the regulator which could cause loss of pressure control.
- ▶ **C.** The pipe joint sealant should be applied on the male threads of the pipe. Do not use any pipe joint material on the female threads of the regulator or it could become lodged in the regulator causing possible loss of pressure control.
- ▶ **D.** Gas must flow through the valve body of the regulator in the same direction as the arrow cast on the body, or the outlet side of the regulator may be overpressured and damaged.
- ▶ **E.** The diaphragm casing may be mounted in any of four (4) positions relative to the body.
- ▶ **F.** When the regulator is installed OUTDOORS, the vent must always be positioned so that rain, snow, moisture or foreign particles cannot enter the vent opening. It is recommended that the vent be positioned to face downward so as to avoid entry of water or other matter which could interfere with the proper operation of the regulator. The vent should be located away from building eaves, window openings, building air intakes and above the expected snow level at the site. The vent opening should be inspected periodically to insure it does not become blocked by foreign material.
- ▶ **G.** When the regulator is installed INDOORS, the vent must be piped to the outside atmosphere while using the shortest length of pipe, the least number of elbows, and having as large a pipe diameter as the vent size or larger. USING VENT PIPE ANY SIZE SMALLER THAN THE VENT CONNECTION WILL LIMIT THE REGULATOR'S INTERNAL RELIEF VALVE CAPACITY. The outlet end of the pipe must be protected from moisture and the entrance of foreign particles. The regulator should be specified by the user with the size vent and pipe threads desired to make the vent pipe connection.

START-UP PROCEDURE

- ▶ **A.** A pressure gauge should be mounted downstream of the regulator to monitor the downstream pressure.
- ▶ **B.** With the downstream valve closed, slowly open the inlet valve. The outlet pressure should rise to slightly greater than the set-point.
- ▶ **C.** Be sure there are no leaks and all connections are tight.
- ▶ **D.** The regulator has been preset at the factory to match specifications given when it was ordered. The outlet pressure may be adjusted by removing the seal cap on top of the spring housing and adjusting the ferrule or screw inside the spring housing using a ratchet with a socket and an extension. With a small amount of gas flowing through the regulator, rotate the ferrule clockwise to raise the outlet pressure and counter-clockwise to lower the outlet pressure.
- ▶ **E.** After the desired outlet pressure is achieved, replace the seal cap, recheck for leaks. The regulator is ready for operation.

SAFETY WARNING:

- This product, as of the date of manufacture, is designed and tested to conform to all governmental or industry safety standards then existing as may apply to the manufacturer.
- ▶ The purchaser and user of this product are warned that compliance with the manufacturer's instructions and procedures is required in order to avoid the hazards of leaking gas resulting from improper installation, start-up or use of this product, and further, that all area fire control, building codes or other safety regulations which regulate or concern the application, installation, operation or general use of this product should be complied with.
 - ▶ In order to insure the safe and proper operation of this product, the manufacturer recommends that this product be installed by a qualified installer.

Vent Lines for Regulators

When constructing vent lines to be attached to regulators installed indoors, a few basic rules must be followed:

1. Never use pipe sizes smaller than the vent size itself; anything smaller will restrict the flow of gas. If a long run must be used, it is advisable to increase the pipe one size every ten feet in order to keep the flow restriction as low as possible.
2. Keep the length of vent line as short as possible to minimize the restriction as well as reduce the tendency for the vent piping to cause pulsation of the regulator.
3. Support the vent pipe so there is no strain on the regulator diaphragm case.
4. Always point the end of the vent pipe located outside the building in the downward position to reduce the possibility of rain, snow, sleet etc. from entering the pipe. A bug screen should be installed in the end of the pipe.
5. The terminus of the vent line must not be located near windows, fans, etc. See the installation instructions furnished with the regulator.
6. All applicable codes and regulations must be adhered to.
7. Vent pipe may cause regulator pulsation. If this situation occurs, please consult your regulator representative or the factory.
8. It is strongly recommended that a separate vent line be run for each regulator; a header with other devices installed in it can cause regulator malfunction.
9. If approved by the authority having jurisdiction, the vent lines may be manifolded in accordance with accepted engineering practices to minimize backpressure in the event of diaphragm failure.

B35 Assembly Positions

Shown are 14 basic positions for assembling models of the B35 series regulators. Please indicate assembly position by number when ordering.

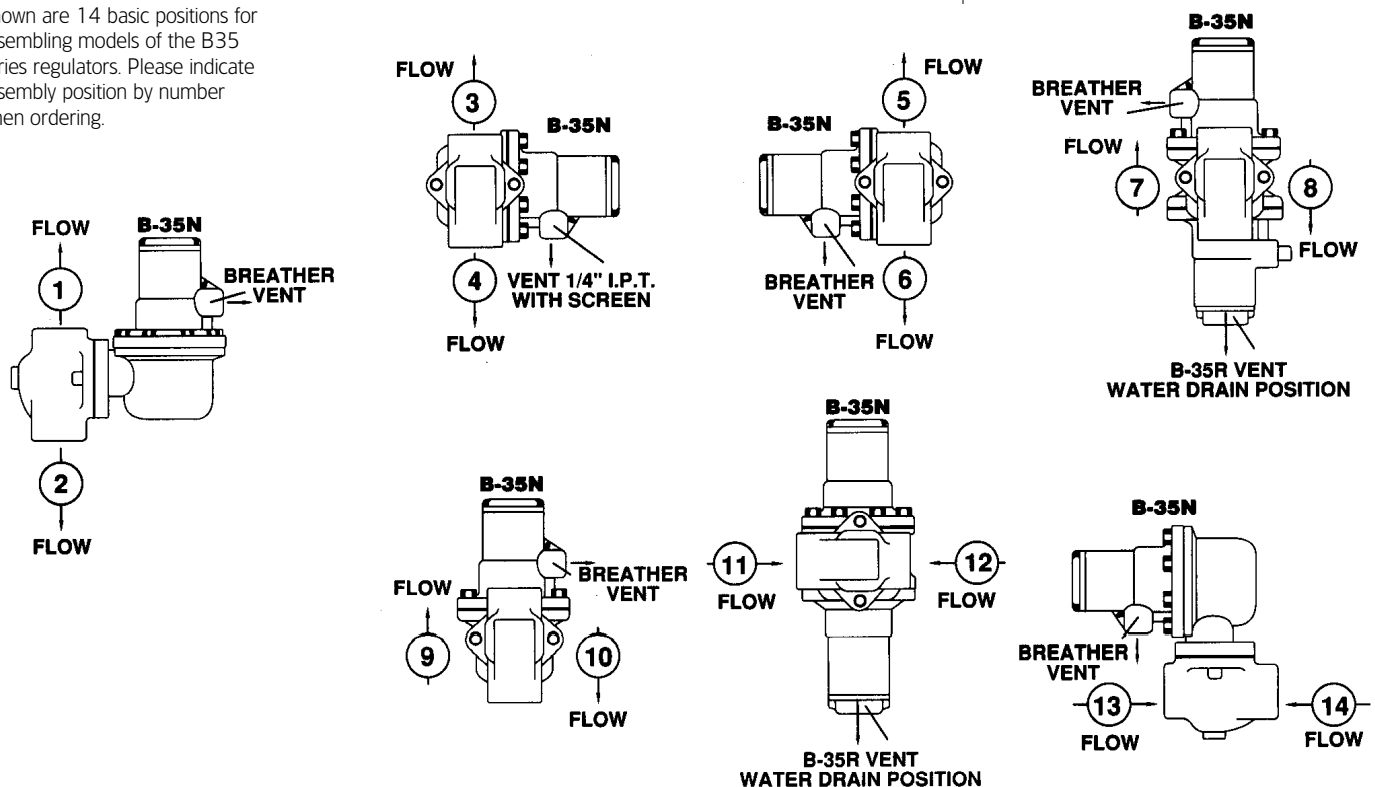

Limited Warranty

Actaris U.S. Gas, Inc. 970 Highway 127 North, Owenton, Kentucky 40359-9302, warrants this gas product against defects in materials and workmanship for the earlier of one (1) year from the date the product is shipped by Actaris or a period of one year from the date the product is installed by Actaris at the original purchaser's site. During such one-year period, provided that the original purchaser continues to own the product, Actaris will, at its sole option, repair any defects, replace the product or repay the purchase price.

• This warranty will be void if the purchaser fails to observe the procedures for installation, operation or service of the product as set forth in the Operating Manual and Specifications for the product or if the defect is caused by tampering, physical abuse or misuse of the product.

► Ordering Information

Specify:

1. Inlet and Outlet Connection Size and Type
2. Model Number
3. Outlet pressure desired
4. Inlet pressure range
5. Type of gas and maximum capacity required
6. Assembly position number (see chart on page 11)
7. Valve Body material

• **ACTARIS SPECIFICALLY DISCLAIMS ALL IMPLIED WARRANTIES INCLUDING THOSE OF MERCHANTABILITY OR OF FITNESS FOR A PARTICULAR PURPOSE. UNDER NO CIRCUMSTANCES WILL ACTARIS BE LIABLE FOR INCIDENTAL OR CONSEQUENTIAL DAMAGES OF ANY KIND WHATSOEVER.**

• Actaris' liability for any claim of any kind, including negligence and breach of warranty for the sale and use of any product covered by or furnished, shall in no case exceed the price allocable to the product or part thereof which gives rise to the claim.

• In the event of a malfunction of the product, consult your Actaris Service Representative or Actaris U.S. Gas, Inc. 970 Highway 127 North, Owenton, Kentucky 40359-9302.

See Actaris Terms and Conditions of Sale for the full and complete terms of the Limited Warranty.

8. Special requirements such as tagging, 1/8" pipe plug tap, seal wire, etc.
9. Type of Vent Cap for R Models (threaded or unthreaded-standard)

► Reference Information:

- Product Overview, JOB

Actaris U.S. Gas, Inc.

970 Highway 127 North
Owenton, Kentucky 40359-9302, USA
For more information, www.actarissusgas.com

tel +1 800 490 0657
+1 502 484 5747
fax +1 502 484 6223